

UC-NRLF



QB 35 571

★ ★ ★ ★ ★

★ LABORATORY-MANUAL ★

★ IN-ASTRONOMY ★

★ ★ ★ ★ ★

★ BY-MARY-E-BYRD ★

★

REESE LIBRARY
OF THE
UNIVERSITY OF CALIFORNIA.

Received 190 ..

Accession No. 82464 . Class No. 3 ..





A
LABORATORY MANUAL
IN
ASTRONOMY

BY

MARY E. BYRD, A.B.

DIRECTOR OF THE OBSERVATORY, SMITH COLLEGE



BOSTON, U.S.A.

GINN & COMPANY, PUBLISHERS

The Athenæum Press

1899

QB62
B9

COPYRIGHT, 1899
BY MARY E. BYRD

ALL RIGHTS RESERVED

82464

PREFACE.

THE laboratory method of instruction is growing in favor so rapidly with astronomical teachers that there is little occasion for any plea in its behalf. It is a recognized fact that the direct investigation of celestial phenomena gives a vividness and reality to the subject and arouses interest and enthusiasm difficult to obtain by any other means. Indeed, to require the study of the heavenly bodies and provide no means for observing them is somewhat like restricting the student of botany to text-books and to pictures of plants.

It cannot be urged as a valid objection to this method that large mathematical attainments and expensive equipment are prerequisites. Laborious investigations necessitating telescopes and observatories are not the ones which should engage the attention of our students at the beginning; but rather the simple observations which teach them how to see and enable them to gather at first hand a store of pleasant astronomical information.

Whether the study of astronomy is taken up first in secondary schools or colleges, years of experience have convinced me that it is best to devote at least one term to general astronomy and naked-eye observation. An unobstructed place for watching the heavens, a few home-made instruments, and evening hours of laboratory instruction will, I believe, do more to foster a genuine interest in astronomy or prepare for the use of instruments of precision than any amount of text-book study which is supplemented only by desultory star-gazing.

The present laboratory manual has grown out of the needs of my own students during the past fifteen years. It is based upon a primer called "Questions on the Sky," which was printed in 1893, especially for the use of students at Smith College. Teachers who have expressed their approval of the primer may be interested to know that the questions given there are republished here with some modifications and additions. After the introductory chapters on almanacs, maps, and globes, all the questions proposed are designed to be answered directly from observation or by data obtained from observation. The one aim and object of the book is to lead to direct study of the heavens.

For the convenience of teachers and students the number of observations suggested is large. Few of them, comparatively, should be undertaken by any one student. But it needs only a modicum of experience to show that astronomy more than other sciences demands large room for choice and adaptation. The factors which condition the work of young observers are so many and varied that teachers within a few miles of each other may require different sets of topics, and students in the same class often work to the best advantage along different lines.

The manual is designed to be used in connection with one of the standard works on general astronomy, like those of Young and Newcomb; and while it has seemed necessary to include a few definitions and explanations, no inroad has been made into the province of the regular text-book, and it has invariably been left to the teacher to call attention to inferences and conclusions which depend jointly upon reading and observing.

The references made to "Young" throughout the book refer to the revised edition of "Young's General Astronomy," and "Elements of Astronomy." The letter E. before the number of the article indicates that the reference is to the "Elements."

All appliances mentioned in the text, except opera-glasses, are home-made, and whatever mechanical excellence they pos-

sess is due largely to Mr. F. King, the Smith College carpenter, and Mr. R. Gellis, the engineer.

To all who have contributed in any way to make the manual complete and serviceable — whether mentioned by name or not — it is a pleasure to accord hearty recognition.

Most of the observations for illustration have been taken by my students and are marked with their initials. Miss Abby E. Tucker, a graduate student, deserves special thanks for making some of the more difficult observations and computing numerical checks. In these as well as in many other directions the help given by my assistant, Miss Harriet W. Bigelow, has been invaluable. I am indebted to her for the index.

Acknowledgment is due Professor Wm. W. Payne, Director of Goodsell Observatory, for permission to use as seemed best several articles of mine which have appeared in *Popular Astronomy*. Through the courtesy of the publishers of *Popular Science Monthly*, an article in that magazine on a "Home-Made Telescope," by Dr. Pyburn, is reprinted as Appendix A of this book.

Appendix B, on "Zodiacal Light," has kindly been prepared by Professor Arthur Searle of Harvard College, and Appendix C, on "Moonrise," by Professor Edgar Frisby of the U. S. Naval Observatory.

I am under special obligation to Professor Edward C. Pickering, Director of Harvard College Observatory, and to Professor Charles A. Young of Princeton University for their kindness in examining the book in manuscript. Their help is gratefully acknowledged.

Suggestions and criticisms from those who use the manual will be gladly received.

NORTHAMPTON, MASS.,
December, 1898.

CONTENTS.



CHAPTER I.

SUGGESTIONS FOR BEGINNERS.

PAGE

| | |
|---|------|
| SECTIONS 1-8. Working-list; Personal bias; Errors; Weights; Numerical records; Distances and angles; Points of compass; Rules for recording | 1-10 |
|---|------|

CHAPTER II.

REFERENCE LINES AND HOME-MADE APPARATUS.

| | |
|--|-------|
| SECTIONS 9-20. Meridian and prime vertical; Gnomon; Protractors; Cross-staff; Circlés; Sun-dial; Transit tube; Home-made telescope | 11-28 |
|--|-------|

CHAPTER III.

ALMANACS AND MAPS.

| | |
|---|-------|
| SECTIONS 21-30. List of Exercises | 29-37 |
| SECTIONS 31-57. Meridian altitudes; Civil and astronomical days; Standard, local, and apparent time; Hour-angles; Old Farmer's Almanac; Moon's southing, time of phases; Tables II and III in the American Ephemeris; Sidereal and mean time; Watch error; Star catalogues and maps | 37-69 |

CHAPTER IV.

CELESTIAL GLOBE AND HELIOTELLUS.

| | |
|--|-------|
| SECTIONS 58-67. List of Exercises | 70-75 |
| SECTIONS 68-86. Orientation; Location of celestial objects; Altitude and azimuth; Graduations for sun-dial; Equation of time; Diurnal path of the sun; Varying length of days; "High" and "low" moons; Diurnal path of a comet; Rising and setting of stars; Synodic period of Venus | 75-99 |

CHAPTER V.

THE SUN.

PAGE

| | |
|--|---------|
| SECTIONS 87-98. Questions | 100-104 |
| SECTIONS 99-123. Position of sun at noon, at any hour; Change in sunrise point; Diurnal path and rate of motion; Length of day; Time from the Circles, sun-dial, gnomon and transit tube; Latitude and inclination of the ecliptic from sun's altitude at the solstices; Refraction shown by sun-dial; Length of twilight; Partial eclipse | 104-136 |

CHAPTER VI.

THE MOON.

| | |
|--|---------|
| SECTIONS 124-133. Questions | 137-143 |
| SECTIONS 134-150. Diurnal path; Time of rising and setting; Rate of motion; Hunter's moon; Rising of full moon; Direction of moon's horns; Synodic and sidereal periods; Time from altitude, time and longitude from meridian transit; Surface markings; Eclipse; Halo | 143-169 |

CHAPTER VII.

PLANETS, COMETS, AND SHOOTING STARS.

| | |
|---|---------|
| SECTIONS 151-159. Questions | 170-175 |
| SECTIONS 160-178. Mercury identified; Visibility of Venus in day-time; Elongation of Venus; Diurnal paths of Venus and β Orionis; Relative motion of Venus and Jupiter; Conjunction of Mars and the moon, of Mars and η Cancri; Paths of Mars and Jupiter among the stars; Jupiter's satellites in an opera-glass; Right ascension and declination of Saturn with cross-staff; Uranus identified; Time from Mercury and Jupiter; Leonids in 1898 | 175-195 |

CHAPTER VIII.

STARS AND MILKY WAY.

| | |
|--|---------|
| SECTIONS 179-190. Questions | 196-202 |
| SECTIONS 191-208. Cardinal points; Constellations; Motion of the great dipper, of the ecliptic; Latitude from altitude; Time from altitude, from altitude and azimuth, from meridian transits; Sidereal and solar days; Double stars with an opera-glass; Variable stars, Algol, Mira; Motion of the Milky Way | 203-229 |

CHAPTER IX.

OBSERVATIONS FOR AN INCH-AND-A-HALF
TELESCOPE.

| | PAGE |
|---|---------|
| SECTIONS 209-213. Questions | 230-235 |
| SECTIONS 214-225. Diameter of sun, rotation from sun spots; Lunar objects identified; Partial eclipse of the moon; Jupiter's satellites; Vesta at opposition; Comet <i>b</i> , 1898; Doubles in Cygnus; Præsepe; Section of the Milky Way | 235-246 |

APPENDIXES.

| | |
|---|---------|
| <i>A.</i> A home-made telescope | 247-251 |
| <i>B.</i> Suggestions to observers of the zodiacal light | 252-257 |
| <i>C.</i> A short method of finding the time when the moon rises and sets | 258-261 |
| <i>D.</i> Hour-angles of the moon on the horizon | 262 |
| <i>E.</i> Latitudes and longitudes of places mentioned in the text . . . | 263-264 |
| <i>F.</i> Astronomical formulæ employed in the text | 265 |

| | |
|-----------------|---------|
| INDEX | 267-273 |
|-----------------|---------|



MANUAL IN ASTRONOMY.



CHAPTER I.

SUGGESTIONS FOR BEGINNERS.

1. **A working-list.** — The humblest star-gazer should watch the heavens with a definite object in view. If the face of the sky is that of a stranger, the plan for the first night may well include nothing more than identifying the North Star and picking out a few of the bright constellations in its vicinity.

A programme as simple as this may answer for several nights; but the constant shift and change going on in the world overhead soon demand more forethought in preparing a working-list best suited for a given night.

The moon must always be reckoned with, for its presence, except when a small crescent, changes the aspect of the whole heavens. The positions of bright stars and planets with regard to the horizon, the meridian, and one another are determining factors in planning observations. Some of the suggestions given in the following chapters may be of service, and it is always admissible to consult almanacs, maps, and globes, if care is taken to obtain no information that will bias the judgment (§ 2). Thus, in preparing to observe a minimum of Algol, the time predicted ought to be known within three or four hours, but in no case nearer than the nearest hour.

The list of exercises should make generous provision for various contingencies on the night in question, since it often happens that many things which look feasible in advance must

finally be omitted. But while plans made beforehand should be comprehensive, the motto for actual work is not "how much" but "how well." It is far better to take a few observations with care and write out full notes than to make scanty records of many hasty observations.

In addition to a specific list of points, it is well to become familiar with a large number of questions about the heavenly bodies, so that when a favorable time comes for answering one in particular, even if it is not on the night's list, the opportunity need not be lost.

The fundamental rule of astronomers to avoid observing objects near the horizon is not applicable to those who depend solely upon their own eyes and rude instruments which give no magnifying power. Under such conditions the importance of dealing with bright objects outweighs any disadvantage arising from twinkling and refraction near the horizon. With wooden quadrants (§ 13) and Circles (§ 16) both altitude and azimuth are measured more accurately when the object is 20° or 30° from the horizon than when it is the same number of degrees from the zenith; and in deriving results by calculation a large zenith distance is often an advantage.

The following exercises are given as an illustration of an actual working-list prepared for Jan. 6, 1897, Northampton, Mass.

1. Note the time and measure the azimuth of the sun at setting.
2. Watch the sunset glow in the west and the twilight bow in the east.
3. Identify Mercury.
4. Describe the conjunction of Venus and the moon.
5. Observe the altitude and azimuth of Vega with the Circles to find the error of the watch employed.
6. Note with the transit tube the meridian passage of one or more of the Orion stars to determine time.
7. Measure the altitude of the North Star for latitude.

8. Test the magnitude of α Ceti by comparing it with several of the stars in its vicinity.

9. Locate Mars by mapping it in connection with the neighboring stars in Taurus.

Clouds and wind prevented carrying out fully half of this programme.

2. Personal bias.— Many beginners have an unreasonable desire to know in advance the correct result. “What ought I to get?” is a question often asked. The only answer is, “You ought to get exactly what you do get, when you have done your best with perfect honesty.”

Experienced, conscientious observers take pains not to know anything that will lead to a predisposition in favor of one value rather than another. They sometimes have a clock set to mark an arbitrary time with an error unknown to themselves. Two astronomers working side by side at the same observatory will watch the same variable star for a number of weeks without the slightest inkling of each other's record. Students cannot learn too soon to see with their own eyes and make their own notes, with little feeling of concern about what has been done before or what their associates are doing at the same time.

During the earlier stages of practice with quadrants and Circles, approximate tests applied soon after observing help to correct faults and secure right methods, but careful checks should usually be deferred till the close of a series of observations. Thus, if the altitude of the North Star is measured on several nights for the purpose of finding latitude, no reduction should be made till the last measure has been taken. Checks, when finally obtained, should not be overvalued. They are not infallible tests of accuracy. Whether derived from the Ephemeris and celestial globe, or computed by formulæ, they are based on ideal conditions which are not found in actual observing.

As an aid in avoiding personal bias it is a good general rule never to reject an observation once taken. Exceptions may occur, but the fact that one measure is discordant when compared with others made at the same time is never a reason for rejection. Discordant values often lead to improved methods, and it is also a curious fact that it sometimes happens that the value which is apparently abnormal is the one of the whole series most nearly correct.

Whatever other means are taken to guard against preconceived notions, it is helpful to cultivate a judicial frame of mind. Do not be anxious and troubled about results. Take observations calmly and deliberately, write down the facts impartially, and then abide by the record.

3. Errors. — The popular impression that errors in physical investigation imply ignorance and incompetency is altogether false. It is the child who says, "I know just how long the table is"; but Professor Barnard, of the Lick Observatory, having taken a series of measures of Jupiter's diameters extending over three years, draws the conclusion that the equatorial diameter of the planet is $38''.522$ with a probable error of $\pm 0''.024$.* Indeed, it is often possible to gauge approximately the accuracy and importance of an astronomical paper by the attention paid to the probable error involved.

Two classes of errors are recognized, accidental and systematic. The former cannot be predicted or calculated. They may have their source in the observer's dinner or in a change of the wind. Systematic errors, on the other hand, follow according to definite law, either known or unknown.

It is an interesting characteristic of accidental errors that they tend to counteract one another; for, if they are truly accidental, each one is just as likely to increase as to decrease the final result, and *vice versa*.

* *Astronomical Journal*, Vol. XIV, p. 102.

Very interesting

While it may be questioned whether it is worth while for naked-eye observers to attempt any discussion of errors, they certainly ought to recognize the fact that errors are inevitable, and make an effort to reduce their final effect to the smallest limits possible. For example, we know that a systematic error is introduced in measuring azimuth with the Circles when the two pointers do not lie precisely in the same vertical plane, but this unknown error is in part eliminated and in part reduced to an accidental error if readings are taken with the vertical circle facing in opposite directions.

4. Weights. — Observations which are made with different instruments and under different conditions are not all equally valuable. An angle estimated with the unaided eye cannot be as trustworthy as if determined with a quadrant, and time obtained from the Circles is not likely to be as accurate as when the transit tube is employed.

Without entering into laborious refinements, we may note two or three general precepts for guidance in assigning relative values or weights.

Whenever observations have been taken with the same instrument and under like conditions, the individual values may be treated as equal, that is, having equal weights; and the final value obtained by simply taking the arithmetical mean.

Most observations of beginners should be planned and executed so as to be combined in this manner, but cases may arise when it is better to employ different weights corresponding to different values. Thus, observations taken with better instruments or under more favorable conditions than others may be considered two or three times as valuable as the latter.

The combination of the three values of latitude derived from noon altitudes of the sun at Northampton, Mass. (§ 114), furnishes an illustration in point.



Since altitudes determined from the Circles and the gnomon are, in all probability, twice as accurate as any measured with the quadrant, the values $42^{\circ} 14'$ and $42^{\circ} 21'$ should be given double weight. This is effected by writing each twice in obtaining the mean, or multiplying each by 2. In either case the mean value is obtained by dividing by 5, the sum of the weights.

Thus, we have :

| | |
|--|--------------|
| Latitude from quadrant, with weight 1, | 42° 54' |
| “ “ Circles, “ “ 2, | 84 30 |
| “ “ gnomon, “ “ 2, | 84 44 |
| Mean, | <u>42 26</u> |

Weights should commonly be assigned at the time of observation, and under no circumstances inspired by any impression of what values will bring out certain desired results. Indeed, the danger of personal bias is an objection to the use of weights by inexperienced students. It is better, instead of giving anxious thought to the relative value of observations, to follow the rule never to take an observation unless the weather and other conditions make a good observation highly probable.

5. Numerical records. — It is important in using any instrument to decide upon the smallest fraction to be retained and then always abide by that limit. For example, if the tenth of a degree is taken as the limit in reading angles from the Circles, do not sometimes read to whole degrees only, and at other times to hundredths. Employ also the same kind of notation. That is, avoid mixing common fractions, minutes, and tenths of degrees. There is, however, no objection to expressing a mean value in minutes of arc when the individual values are given in tenths of a degree.

Remember that *O* is a figure as truly as *1*, *4*, or *7* and should always be written if such figures would have been written in

its stead. We do not mean the same thing by saying that the sun's altitude is 60° , as by the statement that it is $60^\circ.0$. In the latter case we claim to know the altitude to tenths of a degree, in the former only to whole degrees.

Follow a definite rule in treating the fractions beyond the limit. Anything over a half should always be counted as a unit of the next higher order, thus, $0^\circ.36 = 0^\circ.4$; but if the fraction is exactly one half, employ some arbitrary rule by which it is rejected as often as retained and *vice versa*. For example, we may call a half a whole, when by so doing the preceding figure is changed from odd to even, or, in other words, count a half a whole when it "evens up" the last figure. By this rule, $0^\circ.15$ and $0^\circ.25$ both become $0^\circ.2$, but $0^\circ.35$ is taken as $0^\circ.4$.

In computing be willing to sacrifice meaningless decimal places. The row of figures after the decimal point, which looks very good to beginners, to more experienced observers gives proof of ignorance or a mere pretence of accuracy.

6. Distances and angles. — The use of home-made instruments in measuring angular distances is fully explained in the following chapters, and little need be said here except to caution students that they should become familiar with more than one instrument. In regard to eye-estimates it is well to call attention at once to a few points.

The sun and moon, though often suggested as convenient units for measuring small distances, are so bright compared with the background of the sky that they should be avoided as far as possible.

The stars are the main dependence for making direct measures in the heavens. They are preferably chosen in that quarter where the unknown distance is to be determined. If that, for example, lies at an altitude of about 50° and nearly perpendicular to the horizon, the measuring line joining two stars

should conform approximately to the same conditions. In length it may agree closely with the line sought, and in any case ought to be a convenient multiple or divisor of that line.

It is not necessary to know in advance the value of star-lines in degrees. That is readily determined later from the celestial globe or by calculation (§ 72).

We often find it desirable in mapping heavenly bodies to estimate the angle formed at a star or planet by lines drawn to neighboring objects, but the method just described is hardly applicable, owing to the difficulty of carrying an angular unit from place to place in the "mind's eye." Perhaps the best plan is to select favorable times and objects placed so that the required angle is nearly a right angle or a half or a third of a right angle.

In all direct estimates in the sky, be on guard against making distances near the horizon too large and those near the zenith too small. Do not allow a notion of angle or distance to become stereotyped, but let the eyes receive each impression impartially — as if the retina were a photographic plate.

Whatever method is employed in finding distances and angles, it is better to take three or four measures in quick succession than to spend five or ten minutes upon one. The mean of several will, in all probability, be more accurate than the one value obtained with special pains and effort. It will certainly be more free from systematic error (§ 3).

7. Points of compass in the sky. — North and south are terms employed on the earth in referring the relative position of places to the earth's poles. On the celestial sphere, in like manner, north and south indicate position with regard to the corresponding celestial poles, or, in other words, north is toward the star Polaris and south in the opposite direction.

There are, however, no points in the heavens like the cardinal points east and west upon the earth; and therefore we cannot

properly speak of east and west in the celestial sphere, but only of an eastward or a westward motion.

In order to determine in which of these directions a given object is moving, we note its screw motion, that is, whether it goes with the hands of a clock or against them. Thus, if we look south, facing an imaginary clock dial with the XII toward the zenith, we find that the sun in its annual course is moving against the hands. The proper motion of the moon is in the same direction, the planets sometimes go with the hands and sometimes against them; but the diurnal motion of all these bodies is with the hands of the clock. These directions of motion hold good for the whole heavens if in imagination we view the celestial sphere from a point, infinitely removed, on its axis prolonged northward.

According, then, to this convention, since the sun's annual motion is called eastward, we conclude that counter *clock-wise* motion is eastward and *clock-wise* motion westward.

8. Rules for recording. — Many of the following rules are observed by astronomers in keeping their own records, and most students, it is believed, will find all of them serviceable.

1. Begin each night's record on a separate page.
2. Date each page, giving both the day of the week and the day of the month.
3. Record, each night, the place of observing and the time of beginning and ending.
4. Enter the record in connection with the observation or immediately afterward.
5. Name in connection with every observation any instrument employed.
6. Give a full description of every instrument, if possible when it is first used.
7. Write out the notes in detail so that others following them could take the same observation in the same way.

8. For every answer give some data obtained directly from observation.

9. Make all answers complete in themselves.

10. Keep all records of direct, original observations in pencil.

11. Make all corrections of the original record in ink.

12. Enter copied observations in ink, giving two dates, the date of observing and the date of copying.

13. Write in ink answers that depend upon several observations taken on different nights, giving references to the different dates.

CHAPTER II.

REFERENCE LINES AND HOME-MADE APPARATUS.

MANY questions about the motions of heavenly bodies, the face appearance of the sun and moon, and the changing brightness of stars can be answered with no mechanical aids whatever, but for measuring angles and finding time the rudest instruments are better than none. In fact, quadrants, circles, and transit tubes which a carpenter can make are more serviceable for beginners than the complicated and expensive instruments of an observatory.*

Perhaps a word of caution against devoting too much time to home-made appliances may not be amiss. They are not designed like the instruments of Tycho Brahe for a life work in astronomy, but merely as helps in preliminary study and training.

In describing a few of the simple pieces of apparatus which the writer has found useful, various details have been given, more by way of suggestion, however, than with the idea of furnishing exact models.

The following directions for reference lines apply directly to places of observation on the ground, but simple modifications will adapt them to flat roofs or other observing stations.

9. Meridian line. — The place chosen for locating a north and south line should be comparatively level and command a view of the heavens down to the horizon, toward at least two points

* See an article by Professor Newcomb in the *North American Review* for August, 1881.

of the compass. The east and south or south and west are to be preferred.

The determination of a true meridian line on the earth's surface taxes the resources of the astronomer and geodesist, but simple devices serve for drawing lines which meet most of the needs of naked-eye observers.

A large flat stone set in the ground, levelled and made approximately even with the surrounding surface, furnishes a good foundation, and after two points have been determined, the line may be traced with the end of a file and marked with white paint. If the variation of the compass is known approximately at the place of observing, that instrument doubtless furnishes the easiest means of fixing these points.

a) *Shadow of a wall.* Since the shadow of a vertical line falls north at apparent noon, an approximate meridian line may be determined from the shadow cast by the intersecting edge of two walls.

OBSERVATION. — Smith College Observatory, Northampton, Mass., Saturday, Jan. 11, 1896. A smooth surface of snow even with the north meridian stone was prepared for the shadow of the east wing of the building. At the signal for apparent noon two observers placed small nails in the snow to mark the eastern boundary of the shadow which fell several feet east of the stone.

Between these marks a line was traced by pressing down a straight edge of wood. The mean of several independent measures made at two points 4.5 feet apart gave a deviation of about 0.6 of an inch to the east at the north end, when compared with the reference line painted on the stone, a line which agrees quite accurately with the meridian of the transit instrument.

Another line 4 feet in length drawn in a similar manner several weeks earlier, when the shadow was longer and its edge sharper, deviated 0.1 of an inch to the west at the north end.

The accidental errors appear to be unreasonably large in these determinations, but walls are at best not very trustworthy aids.

b) *North Star and plumb lines.* One device sometimes employed in obtaining a north and south line consists simply in bringing two plumb lines into line with the North Star.

According to this method a line was located at Northampton, May 31, 1897, when the star was near lower culmination. Two tripods 10 feet in height with plumb lines attached were placed about 3 feet apart on the north meridian stone. Both lines were well lighted by lamps set in a window of the observatory, and the line farther north was shifted from side to side by an assistant till the North Star, when carefully sighted, appeared to be in line with the two plumb lines. While making adjustments, the observer took pains not to know anything about the position of the plumb lines with regard to the reference meridian line. Afterward measures made of the distances, about 3 inches, from the centre of the bobs to this meridian showed a deviation of 0.22 of an inch to the east at the north end of a line 36.55 inches in length.

The theoretical deviation of the line may be computed, since the time of observation was known; for the hour-angle, $30'.8$ is readily derived from this time (§ 39), and with the declination $88^\circ 45'.5$ taken from the Ephemeris, we find by calculation that the corresponding azimuth of the North Star was $180^\circ 13'.8$ (§ 75).

Our problem is then to determine the linear deviation at the north end of a north and south line, located by the North Star when it has an azimuth of $180^\circ 13'.8$.

In Fig. 1, let NC , taken as 36.55 inches, be the projection of the given line on the meridian, and NCE the angle $13'.8$,

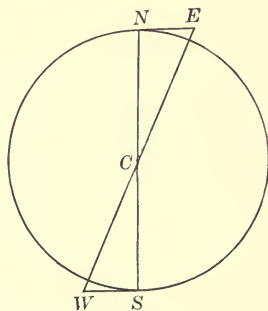

FIG. 1.

whence NE , the required deviation, is found by plane trigonometry to be 0.15 of an inch, giving a difference of 0.07 of an inch between observation and theory.

c) *Shadow of a plumb line.* Instead of using plumb lines as a rude transit instrument to locate an approximate meridian, we can fix its position by watching the shadow of a plumb line in the daytime. (See Dialling, "Encyclopædia Britannica.")

The essentials of this method consist in suspending a plumb line, on a very still day, to the south of a level surface, and then marking on the surface a number of points where the shadow of a bead or knot on the line falls at equal intervals before and after noon. The line connecting two symmetrical points lies nearly east and west.

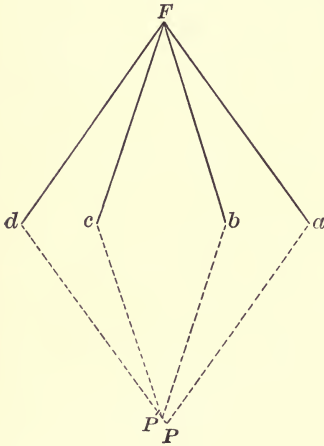

FIG. 2.

The foot of the plumb line gives one point in the required line, and another may be found by striking arcs and bisecting the east and west line, but if the meridian is being traced on a stone out of doors the same geometrical principle is applied more accurately by the use of two rulers, as illustrated in Fig. 2.

Let F in this figure be the foot of the plumb line and a, d and b, c be two pairs of symmetrical marks locating the shadows of the knot at successive times. The lines Fa and Fd give the position of two long rulers which, having been marked at a and d , are turned over end for end, so as to keep these marks in coincidence with those on the stone. In this position, the end of the rulers which first met at F are brought together again and fix the point P in the meridian.

Theoretically, any pair of symmetrical marks should locate a point in the same north and south line, but if measures are carried to hundredths of an inch, we shall doubtless find that P' , derived from b and c , deviates a little to the east or west when compared with P obtained from a and d . The second point in the meridian line should therefore be determined from several pairs of symmetrical marks fixed by the shadow.

A permanent meridian line ought not to be located hastily. At first we may employ as a reference line one drawn roughly north and south, but the final position should depend upon a number of independent determinations. Transits of heavenly bodies observed with plumb lines or transit tube (§ 18) should give a good practical test of the final line. Perfect accuracy is not to be expected. That is beyond the reach of skillful astronomers working with the most expensive and refined instruments.

The error in fixing the meridian is a systematic error; but in using the line accidental errors (§ 3) are also involved. When the Circles (§ 16) or transit tube are placed on any line, there will probably be an error of several hundredths of an inch; the slightest displacement of the upright shaft moves the vertical circle out of the plane of the meridian, a breath of air affects the plumb lines in the same way, and in no case does the observer note the exact instant when the celestial object is bisected by the pointer or the lines. Since, however, these errors tend to destroy one another, the final results obtained should be more accurate than individual errors taken separately would indicate.

The line which is drawn on a large stone set firmly in the ground cannot be considered permanent from year to year, as the action of the elements tends to shift even solid masonry.

10. Prime vertical line. — After a meridian line has been established, any means by which one line is drawn at right

angles to another suffices for locating an east and west line. An independent determination of such a line may be made, at least approximately, at either equinox, since at these times the shadows at sunrise and sunset fall nearly due west and east.

In order that a number of students may take the same observation at the same time, approximate reference lines may be prolonged and marked as "courts" are marked in lawn tennis.

11. Gnomon.— A common post set roughly in the plane of the meridian is helpful in making a number of observations with quadrants and jointed rulers, but if the sun's altitude or the time of apparent noon is required with some degree of accuracy, more pains must be taken.

When a permanent meridian line has been marked on the surface of a flat stone, we may employ for a gnomon a straight edge of wood set vertically at its south side, in the plane of this line. Instead of driving such an upright directly into the ground, it is better to place it in a narrow box which can be shifted slightly in one direction or another.

The box which I have used is made of chestnut, 2 feet deep and 2 by 4 inches on the inside. It is set in the ground as nearly as possible at right angles to the stone, the top being even with it. The piece of studding which serves for an upright fits rather loosely into this box, and by means of small wedges is made to stand vertically, within the limits of error of a carpenter's level.

When a gnomon like that just described is first set up, it should be tested on several days by noting whether the edge of the shadow falls on the centre of the meridian line at apparent noon. If found necessary, the box can be moved a little by driving wedges down beside it.

Thus, we use apparent noon to place the gnomon correctly, and then use the gnomon to find apparent noon. In like

manner, astronomers employ a clock to place a transit instrument in the meridian and then take observations with the instrument to correct the time of the clock.

Since the noon shadow of a gnomon varies largely from month to month, the length of the stone or platform prepared for the shadow, as well as the latitude of the place, must be considered in determining the height of the gnomon.

EXAMPLE. — Given a meridian stone, 5 feet in length, find the height of a gnomon at Springfield, Mass., whose shadow shall not fall beyond the edge of the stone when the sun's altitude is least.

If the sun's greatest southern declination is taken $-23^{\circ} 27'$, and the latitude of Springfield, $+42^{\circ} 6'$, as given in the state geodetic survey, the corresponding noon altitude of the sun is $24^{\circ} 27'$ (§ 32).

In Fig. 3 let AC equal the height of the gnomon, and BC the length of the shadow it casts at apparent noon on the day of the winter solstice. Then ABC is the sun's angular elevation at that time, or $24^{\circ} 27'$. As it is not easy to measure the shadow accurately unless it is a little shorter than the stone, let us take its length, 59 inches. Then, by trigonometry, we have

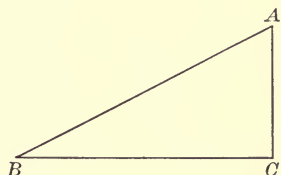

FIG. 3.

$$\tan 24^{\circ} 27' = \frac{h}{59}, \text{ or } 0.4547 = \frac{h}{59},$$

and h , the height of the gnomon, is 26.8 inches.

The use of gnomons of different length from season to season secures a comparatively long shadow for varying altitudes of the sun, and if movable shafts are employed changes are easily made. These uprights when not in use should be placed on the floor of a room with a dry, even temperature, and the box, if left in the ground, covered to keep it clean and dry.

12. Rulers and protractors. — One of the simplest means for measuring angles in the sky is obtained by the use of two rulers and a protractor. Thus, we may find the altitude of a heavenly body by placing one ruler parallel to the plane of the horizon and adjusting another laid upon it till it is in line with the eye and the given object. By laying the rulers in the same position on a protractor, the angle is read off in degrees.

The rulers are more convenient to handle if they are fastened together by a rivet on which each turns easily. A good length for the arms is 15 or 18 inches when their width is about 0.5 of an inch.

One method employed in making a protractor may be described briefly as follows:

A wooden disk 15 inches in diameter was turned at a planing mill, its under surface made crown-shaped to prevent warping, and the other, as nearly plane as possible, coated with shellac and smoothed off with sand paper. On the surface thus prepared was mounted a paper protractor,* graduated to quarters of a degree, and the whole was then finished with three coats of shellac.

13. Quadrants. — A very unpretentious quadrant † may be made by fastening a strip of steel, graduated to 90° , between the arms of the jointed rulers. In order to graduate the scale, let it be placed edgewise on the circle of the protractor just described, and points marked corresponding to every 10° . Afterward, other divisions may be secured by means of a flat card scale made from the protractor.

When mounted, the scale stands edgewise on the arms, playing freely through a wire loop on one, and being firmly attached

* All of the protractors used for our instruments have been obtained from Keuffel & Esser, New York.

† This form was devised by Miss Abby E. Tucker, a student at Smith College Observatory.

to the other. Its distance from the rivet measures 7 inches, the radius of the protractor employed.

14. Cross-staff. — Before telescopes were invented, angular distances in the heavens were sometimes measured with the cross-staff. It was used by Tycho Brahe, and his records contain some angles determined with its help, though he calls it an untrustworthy instrument.

Our cross-staff was made from the following description given in Dreyer's life of Tycho Brahe :

“It [the cross-staff] consisted of a light graduated rod about three feet long, and another rod about half that length, also graduated, which at the centre could slide along the longer one, so that they always formed a right angle.”

There are various ways of placing the sights. In our instrument there is one near the eye end of the main rod, but the shorter cross-piece, instead of being graduated, is provided with three pairs of sights placed accurately at 2.5, 4.0, and 8.0 inches from its centre. Stiff strips of steel serve as springs to hold this cross-piece firmly at right angles, and a handle is provided for the two rods on the under side, at the point of intersection.

15. Azimuth stand. — For measuring angles along the horizon a circular protractor (§ 12) may be mounted on a tripod stand. In the instrument to be described, the protractor has a slight angular motion on the stand upon which it can be firmly clamped. A steel rod about a quarter of an inch in diameter is used for a pointer. It passes through a slot in the head of a long bolt set in the centre of the protractor, and is controlled by a thumbscrew on the under side of the stand, by which it is tightened or loosened.

To place the instrument in the meridian, a plumb line fastened to the edge of a gnomon is passed over a support on the upper part of the tripod stand which raises it a little from the surface of the protractor. By moving the whole frame the bob

is then made to come to rest over the meridian line on the stone, and the protractor turned till the marks for 0° and 180° are exactly under the plumb line. An instrument of this kind is, however, of little use without a good horizon.

16. The Circles. — The idea of making a rough altazimuth instrument out of two circles and an upright shaft I obtained from a description of such an instrument kindly given by Professor W. A. Rogers of Harvard University. But years of use* with students have led to many minor additions and modifications, so that the writer is alone responsible for the particular form described here.

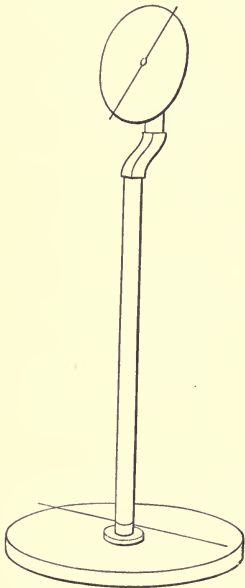

FIG. 4. — The Circles.

The Circles, illustrated in Fig. 4, consist of a vertical and a horizontal circle connected by an upright about 5 feet in height. The vertical circle is a protractor 15 inches in diameter, like that for the azimuth stand, except that the graduations are divided into quadrants instead of being numbered continuously. The lower circle, about 30 inches in diameter, is mounted on a circular frame so that the height of the whole is 3 inches. A wide cleat screwed on the under side lessens the danger of warping.

After heavy paper had been pasted on the base, graduations were obtained from an unmounted protractor (§ 12) which was held firmly in place on the surface while every degree mark was carried out with rulers to the circumference of the larger circle.

The pointer of the base is a steel rod passed through the lower part of the upright, and turning with it through 360° .

* See article by the writer in *Popular Astronomy*, February, 1894.

The pointer for the vertical circle is like that used with the azimuth stand.

One of the most difficult adjustments connected with the Circles is to place and keep the upright shaft in a vertical position. In the instrument described, the lower part of the upright is shod with iron and fits into an iron socket, 3 inches deep, inserted in the centre of the base. Both "shoe" and socket were cast with wide flanges, so that the upright rests with a broad base upon the horizontal circle. This circle was carefully levelled, and the upright set as nearly vertical as possible before being fastened into the shoe.

Several other adjustments are required for this instrument. The extremities of the horizontal pointer should be separated by 180° . To effect this, the socket for the upright should be carefully centered and small wedges may be driven in beside the pointer.

Before the vertical circle is screwed firmly in place, it can be shifted a little, as indicated by a carpenter's level, so that the line from which altitudes are reckoned is made horizontal, as nearly as possible.

The fourth adjustment, that of bringing the two pointers into the same vertical plane, is provided for in part by an offset in the upright just below the vertical circle. To find the deviation still remaining, plumb lines may be hung from a long rod, replacing the pointer of the vertical circle. If the bobs come to rest over the axis of the horizontal pointer, the adjustment is satisfactory, and this result is obtained with a fair degree of accuracy by inserting thin wedges between the upright and the back of the vertical circle.

17. A horizontal sun-dial. — Before considering mechanical construction, a few words may be given to the numerical calculation required in making a horizontal dial.

The formula to be employed (see Dialling, "Encyclopædia Britannica") is

$$\tan A = \tan t \sin \phi \quad (1)$$

where ϕ is the latitude of the place, t any given hour-angle, and A the corresponding angle between the noon line and the hour mark on the dial.

EXAMPLE. — In latitude $42^\circ 19'$, what is the angle on the horizontal sun-dial between the noon line and the graduation for $9^{\text{h}} 15^{\text{m}}$ A.M., apparent time?

Since the given time is before noon, t equals an east hour-angle of $2^{\text{h}} 45^{\text{m}}$, or $41^\circ 15'$, and by the formula we have

$$\begin{aligned} \log \tan 41^\circ 15' &= 9.94299 \\ \log \sin 42 \quad 19 &= \underline{9.82816} \\ \log \tan A &= 9.77115 \end{aligned}$$

and A is equal to $30^\circ 33'$, the required angle.

The value of this angle measured on the celestial globe is $30^\circ.7$ (§ 76).

On account of the symmetry of the dial on either side of the meridian and the prime vertical, it is only necessary to make the calculations for 6 hours and all other values are known directly.

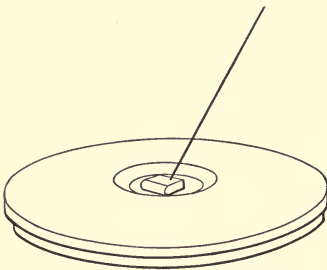

FIG. 5. — Horizontal Sun-dial.

Fig. 5 illustrates a horizontal sun-dial made for Northampton, Mass., and graduated to 5 minutes for the longest day at that place. Its base was made at first exactly like that of the Circles, a paper protractor centered and the computed angles laid off; but

after the graduations were completed, a section was cut out of the centre in order to bring the adjusting screws of the style below the level of the dial face.

The proper placing of the style is the crucial problem in a horizontal dial. Its elevation should be equal to the latitude of the place, and its axis should lie in the plane of the meridian. The following method of adjustment has been employed with our home-made instrument.

The dial is placed on one of the meridian stones (§ 9), its noon line brought into the plane of the meridian line, and the base levelled. Then a thin piece of wood with an angle $42^{\circ}.3$ is held in a vertical position on the noon line, and the style raised or lowered, and moved to the right or left by the adjusting screws till it rests centrally throughout its length on the slanting edge of the pattern. As a final test a plumb line is hung from the end of the style, and if the bob falls over the centre of the meridian line, the adjustment is considered satisfactory.

18. A transit tube. — I have given the name transit tube to a rude transit instrument employed in finding time from the meridian passage of the sun, moon, planets, and bright stars. Its essential parts are a tube and two plumb lines. These should be mounted and adjusted so that the lines fall freely through slots in the tube, and the bobs come to rest over two points in a meridian line.

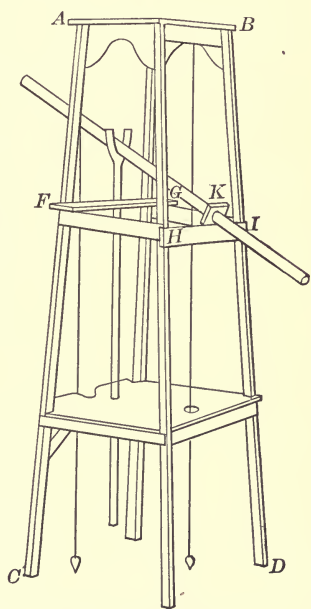

FIG. 6. — Transit Tube.

One method of obtaining these results is illustrated in Fig. 6. The wooden frame *ABCD* is about 6 feet in height. The object end of the tube rests in the V of an upright shaft which slides in a circular aperture in the horizontal bar *FG*, and can be

clamped at altitudes varying from 0° to 45° . To give play for this motion at the eye-end, the lower part of the tube passes through a block, *K*, attached by hinges to the horizontal bar *HI*, so that it moves in and out like a little door.

The tube is made of tin, painted black on the inside, like a telescope tube. Its length is about 4 feet, and its diameter 1.5 inches.

To facilitate the adjustment of the plumb lines, the bars *FG* and *HI* can be moved to the right or to the left a little by means of slots and thumbscrews. A like motion is given to the support, on which is fastened the line near the eye. The other is attached to a straight edge of wood, which moves backward and forward in line with the axis of the tube, so as to vary the distance about 6 inches between the plumb lines.

The wind is the greatest drawback to the use of a transit tube. It is not worth while to try to do anything with it, if the wind is blowing hard, but if the lines are only slightly disturbed, they may be steadied after adjustment by placing the bobs in jars filled with water.

At night we suspend a tiny lamp so as to light up the outer thread, and against it the inner one shows dark, giving a good reference line without making the field very bright.

19. A home-made telescope.—The essential parts of a small telescope are few and simple. Four lenses are required, two for the object-glass and two for the eye-piece. They should be chosen so as to secure a long focal distance, and a magnifying power of not less than 20 diameters.

The main tube ought to be a little shorter than the focal length of the object-glass, and a little larger in diameter, so as to leave room for wrapping strips of soft cloth or tissue paper about the cell of the objective. The short tube forming the eye-piece must be adjusted to move easily for focusing, and it is well to mount it in a tube long enough to cut off the light coming from the edges of the field.

For more detailed instructions regarding a home-made telescope, the student is referred to Appendix A of this manual.

20. Tests for an inch-and-a-half glass.—a) *Light-gathering power.* Even a small telescope brings to the observer much more light than the unaided eye; for the light which falls on different surfaces is proportional to their areas, and the pupil of the eye is only about 0.2 of an inch in diameter.

Since the areas of circles are to each other as the squares of their diameters, if L and L' represent the quantities of light which fall on the eye and on the objective, we have the proportion

$$L : L' :: (0.2)^2 : (1.5)^2, \text{ or } L' = 56.2 L.$$

In passing through the four lenses of a telescope about 0.2 of the light is lost, so with an aperture of 1.5 inches 45 times as much light is obtained as with the naked eye under like conditions.

b) *Focal length.* The focal length of a telescope is the distance between the object-glass and the point where it forms a distinct image of the object observed.

To determine the focal length of home-made telescope No. 1 of Smith College Observatory, the eye-piece and draw tube were removed, and the main tube containing the object-glass directed to the sun. A piece of cardboard held at right angles to the tube was moved back and forth till the sun's image was most clearly defined and the distance then measured between the end of the tube and the cardboard. Five measures gave a mean of 1.75 inches, which, added to 27.81 inches, the length of the long tube, gives 29.6 inches as the focal length of this telescope.

c) *Magnifying power.* If the focal length of the object-glass is known, and that of the eye-piece as a whole, the magnifying power of a telescope is obtained by dividing the former by the latter. According to another method, we divide the diameter of the object-glass by that of the emergent pencil of light (Chau-

venet's "Spherical and Practical Astronomy," Vol. II, Art. 13). The latter diameter is found by measuring the little circle of light which is seen on the eye-piece when the eye is removed 10 or 12 inches. For this purpose Berthon's dynamometer may be employed, or a home-made scale,* like that illustrated in Fig. 7.

The scale in the figure is made nearly full size, but a few directions may not be amiss.

On a strip of paper 6 or 7 inches in length and about 0.8 of an inch wide, draw the rectangle $ABCD$, making it 5 inches by 0.5 of an inch. Having drawn the diagonals AC and BD , graduate the right-hand half of AB to 0.05 of an inch, and through the 50 points pass lines parallel to BC . The difference in the length of these lines, 0.01 of an inch, gives the limit to which the scale measures directly.

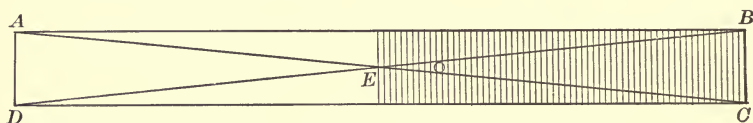

FIG. 7.

A scale thus made, having been dipped in kerosene to render it transparent, was used in finding the magnifying power of the telescope mentioned above. After the stellar focus had been obtained, the scale was placed close to the eye-piece, and moved slowly till the circle of light was tangent to the lines BE and CE . The paper held over the graduations was then slipped aside, and the fraction of an inch intercepted at that point read and recorded.

In this way 30 measures were made on 6 different days, giving a mean of 0.065 of an inch for the diameter of the emergent

* To whom is due the credit of inventing the scale, I do not know. Professor Pickering of Harvard College Observatory gave me instructions for making it, but he says that the device was shown him by an English astronomer, Dr. Schuster, he thinks, though whether it was original with him, he does not know.

pencil of light; and as the objective is 1.5 inches in diameter, the magnifying power of the telescope, according to this determination, is 23 diameters.

d) *Field of view.* The field of view may be described as the section of sky which is visible at one time with a given telescope. It may be determined by timing the transit of an equatorial star across the centre of the field when the telescope is in the meridian. If the star has north or south declination, the observed interval is reduced to the corresponding interval on the equator by multiplying by the cosine of the declination. The formula to be employed is

$$i = I \cos \delta^* \tag{2}$$

where δ is the declination of the star observed, I the time found directly, and i the required equatorial interval.

OBSERVATION. — Smith College Observatory, Thursday, Apr. 9, 1896. Home-made telescope No. 1 was placed approximately in the meridian by means of the line marked on the second meridian stone to the south of the observatory. A little before the transit of α Hydræ, the telescope was directed to that star, and the following record made by a common watch :

| | |
|----------------------|--|
| Star entered field, | 7 ^h 57 ^m 55 ^s |
| “ left “ | 8 1 7 |
| Interval of transit, | 3 12 |

By adding 0.5 of a second to this interval, we obtain its value in sidereal time (§ 48), and then make the reduction to the equator thus,

$$\begin{aligned} \log (3^m 12^s.5) &= \log 192^s.5 && = 2.2844 \\ \log \cos (-8^{\circ}.2) &= 9.9955 \\ \log 190^s.5 &&& = 2.2799 \end{aligned}$$

Hence the diameter obtained for the field of view is 3^m 10^s.5. In like manner, three other observations were taken, one more

* Art. 131, Vol. I, Chauvenet's "Spherical and Practical Astronomy."

of α Hydræ and two of γ Ursæ Minoris, when it crossed the meridian below the pole. The mean of the four values makes the diameter of the field of view $47'$, or $3^m 8^s$.

It was of course difficult to be sure of a central transit for any star, as the diameters of the field are marked only roughly by the cross-threads.

e) *Images.* Since the different parts of a home-made instrument are not rigidly fastened together, it is difficult to keep the lenses at right angles to the axis of the telescope, and consequently the image of a bright object is often distorted, especially when inexperienced students are learning to observe.

The correction of the so-called "wings" is best made on a clear evening when each tentative adjustment can be tested by pointing on the moon or other bright object.

Our home-made telescopes do not meet satisfactorily the theoretical tests for spherical and chromatic aberration, but little inconvenience arises in actual use from either defect, a result to be expected from a small instrument with long focus and low magnifying-power.

Proctor's "Half-Hours with a Telescope" is one of the best handbooks to employ in adjusting and testing an inch-and-a-half glass.

CHAPTER III.

ALMANACS AND MAPS.

THE common almanac is the astronomical year book of the elementary student. In order to watch the heavens intelligently, and plan for simple observations, it is essential to have at hand a calendar of astronomical phenomena which gives the times when the sun and moon rise, south, and set; when conjunctions of heavenly bodies occur; when different planets are favorably situated; and other data of a similar character.

As many points connected with times and periods require reference to a longer interval than a year, one or more of the common almanacs should be kept on file.*

EXERCISES FOR THE COMMON ALMANAC.

21. Names, symbols, and aspects.

1. Learn the names and characters of the principal planets.
2. Learn the names and symbols of the signs of the zodiac, and the symbols of conjunction, opposition, and quadrature.
3. Read the calendar pages for September and October, giving the names of all the astronomical symbols.
4. Find whether eastern and western elongations of Mercury for the current year come nearer inferior or superior conjunction.
5. Taking almanacs for two consecutive years, find whether the eastern and western elongations of Venus occur nearer inferior or superior conjunction.
6. In one synodic period of Mercury and in one of Venus, find in what order elongations and conjunctions occur.

* For an account of some methods employed in making a common almanac, see an article by Professor R. W. McFarland in *Popular Astronomy*, No. 23.

22. Sun, moon, planets, and meteors.

1. If the sun's declinations are given, find between what limits they vary during September and between what dates the sign changes.

2. From the sun's declination, find its altitude when on the meridian of a given place.

3. Find what signs of the zodiac the sun enters at the beginning of the different seasons.

4. Explain what is meant by morning and evening, and W. and E. in connection with phases of the moon.

5. If minutes are given in connection with phases, explain what is meant.

6. By examining a file of almanacs, ascertain how often two full moons have occurred in one month during the past ten years.

7. Find a year since 1890 in which there were two months each with two full moons before the month of May.

8. Show how to account for these facts, at least approximately, by the difference in the length of lunar and calendar months.

9. Find what eclipses take place during the current year, and which ones will be visible where you observe.

10. During each month of observation, ascertain what planets are "morning stars" and what are "evening stars."

11. If Venus is an evening star throughout the summer of any year, as in 1895, find when it is an evening star again throughout the summer.

12. Find which of the bright planets, Mercury, Venus, Mars, Jupiter, and Saturn, can be observed conveniently in October or November of the current year.

13. From the Almanac of the Society of Wales, find the number of meteoric showers predicted for the year.

14. Ascertain with what constellations five of the principal showers are connected.

15. Ascertain the marked characteristics of these showers.

16. Compare the number of showers for July, August, and November.

17. Find what notable showers occur annually.

23. Time.

1. Calling a day the interval between sunrise and sunset, find for the place of observation in which month the days lengthen most rapidly, and in which they shorten most rapidly.

2. Find how much the days decrease in length during the twenty days preceding the winter solstice.

3. Find how much the days increase in length during the twenty days following the winter solstice.

4. See whether these changes are due in larger part to the changing time of sunrise or of sunset.

5. Find the dates on which there is the greatest difference in the length of the day at Boston and at Raleigh, when the Boston day is longer than that at Raleigh, and when it is shorter.

6. Explain how local time is obtained from standard time at any place.

7. Explain what is meant by "sun fast," and show how to obtain apparent noon.

8. Show that the quantity called sun fast, in the Old Farmer's Almanac, is the difference between sun noon and standard noon at Boston.

9. Show that this quantity is obtained by combining the equation of time with the difference between standard time and local time.

10. Explain how the Old Farmer's Almanac, which is calculated for the latitude and longitude of Boston, can be used for other places in New England.

11. Compare the tabular correction, given for each place on page 2, with the difference between its longitude and that of Boston.

12. Explain why the tabular correction is subtracted for sun fast, if the place is west of Boston, and added if it is east.

13. Explain why in other cases this correction is added if the place is west, and subtracted if it is east.

14. Having computed the time of sunrise for a given day at Boston, find how much this time varies if the latitude is changed to that of the extreme northern or southern part of New England, the longitude remaining the same.

15. Find whether the civil or astronomical day is employed in the Old Farmer's Almanac.

16. Find when "dog days" begin and end, and their connection with the "dog star."

17. Dr. Jayne states in one issue of his almanac that it is calculated for the latitude 36° , and "is adapted to the states of southern Virginia, North Carolina, Tennessee, Kentucky, Arkansas, and New Mexico." Keeping the longitude of Raleigh, find for a given date how much the times of sunrise vary between latitude 36° and the extreme northern and southern latitudes included.

18. Explain how it is that, for the same date, different times are given in the Old Farmer's Almanac and in Jayne's Almanac for sunrise at Boston.

19. Explain why no corrections for longitude are given in Jayne's Almanac.

20. Show whether Ayer's Almanac is calculated for local or standard time.

21. Ascertain the difference in latitude and longitude between the place of observation and the meridian for which your almanac is computed.

Students should be sufficiently familiar with the "American Ephemeris and Nautical Almanac" to find at first hand the data which are copied directly from this year book into our common almanacs. The spherical coördinates of the sun, moon, and planets given in the Ephemeris are necessary in locating these bodies on star-maps, and checking observed positions on the globe. All celestial phenomena are here given more fully than in a small almanac.

EXERCISES FOR THE AMERICAN EPHEMERIS.

24. The sun.

1. Find the right ascension and declination of the sun for a given day at Greenwich mean noon.

2. Find the sun's longitude for the same day at Greenwich mean noon.

3. Find the difference in the sun's right ascension and declination between two dates of the vernal equinox separated by twenty-five years.

4. Check the sun's declinations given for any month in a common almanac by comparing them with the corresponding values in the Ephemeris.

5. For a particular month, compare the right ascensions and declinations of the sun at the Greenwich and Washington meridians, noting between what limits the differences lie.

6. Having given these coördinates for Greenwich apparent noon, compute their values for apparent noon at Washington on the same date.

7. Show from the maps of the Ephemeris that the path of the next total solar eclipse is correctly given in the common almanac used.

25. The moon.

1. Find the right ascension and declination of the moon for a given hour and minute at the place of observation.

2. By means of the moon's declination, find its altitude when on the meridian of a given place.

3. Ascertain the limits within which the longitude of the moon's ascending node varies during the current year.

4. Find the longitude of the moon's ascending node for March, 1876; June, 1885; and October, 1894.

5. From the moon's age, find approximately its time of southing.

6. Explain the principle of the method employed, and show whether it applies better on some dates than on others.

7. Show why the Ephemeris and a common almanac give different times for the same phase of the moon.

8. Having taken from the Ephemeris the times of the phases for the current month, find the corresponding Eastern, Central, Mountain, and Pacific times.

9. For the next total lunar eclipse visible where you observe, find the local times of beginning and ending.

10. Find for the same eclipse the standard times of beginning and ending.

11. Find on what dates the moon occulted the Pleiades at Washington in 1897 and 1898.

12. If the place of observation is near Washington, find what stars will probably be occulted in a given month.

26. The planets.

1. Ascertain whether the times of morning and evening stars are correctly given in the almanac used.
2. Find what "planetary constellations" occur during each month of observation.
3. Ascertain approximately the standard times at which the bright planets cross the local meridian.
4. As determined by the ratio called k , find on what dates during the year the maximum part of Mercury's disk is illuminated.
5. Find what part of the disk is visible when the planet is favorably placed for observation.
6. Find the corresponding dates for Venus.
7. By means of the data given in the Ephemeris, draw a figure showing what part of the disk of Mars is illuminated in any month.
8. From the configurations given for Jupiter's satellites, explain how they should appear on a given date in the telescope used.
9. By means of the diagram and the tables for the satellites of Saturn, show what ones are favorably situated for observation at a particular time.
10. Compare the text-book definitions of conjunction, opposition, and quadrature with those given in the Ephemeris.

27. The stars.

1. Knowing the right ascension of a star, find it in the Ephemeris.
2. Given a star, find its right ascension and declination in the Ephemeris.
3. Find what stars have their right ascension and declination given for every day in the year.
4. For a particular date, obtain the difference between the mean and apparent place of α Ursæ Minoris.

28. Latitude, longitude, and time.

1. Find the difference in latitude and longitude between Greenwich and the place of observation.
2. Find the difference in latitude and longitude between Washington and the place of observation.

3. Find the difference in the same coördinates between the nearest observatory and the place of observation.

4. Ascertain the difference in longitude between the local and standard meridians of a place.

5. When a clock in Portland, Me., keeping standard time, marks eleven in the morning, state and explain what hour is shown by a clock in Portland, Ore., which is also regulated to standard time.

6. State and explain whether six o'clock in the morning comes later by local or by standard time at Montreal, Can., which is in longitude $+ 4^{\text{h}} 54^{\text{m}} 18^{\text{s}}$.

7. Show under what conditions a gas company would be likely to suffer loss by a change from local to standard time.

8. If the same nominal hour is kept for dinner, find whether you dine earlier by local or by standard time.

9. If local time is kept in Detroit, Mich., and the railway trains passing through use standard time, show whether the local time-pieces are fast or slow compared with train time.

10. Prove that the equation of time changes little for places widely separated, by comparing the values given for the same date at Greenwich and at Washington.

11. Prove that the equation of time changes slowly for the same date by comparing the Greenwich values for September 1 from 1885 to 1895.

12. Find on what dates the equation of time reaches a maximum, and on what dates a minimum.

13. Find the difference in annual precession from 1870 to 1890.

14. By comparing different years, show whether Tables II and III of the Ephemeris can be used for any other than the current year.

15. Given a mean-time interval, find the equivalent sidereal interval.

16. Given a sidereal interval, find the equivalent mean-time interval.

17. Reduce standard time at the place of observation to local time.

18. Reduce standard time to the corresponding Greenwich time.

19. Reduce local time to the corresponding Greenwich time.

20. From the standard time at a given meridian, obtain the corresponding sidereal time.

21. From the sidereal time at a given meridian, obtain the mean local time.

22. If a sidereal clock-dial marks only 12 hours, explain when face time is correct, and when 12 hours must be added.

23. From the hour-angle of a star at a given meridian on a given date, find the local mean time.

24. Having given the right ascension of Spica, compute the standard time at which the star crosses the local meridian some evening between seven and ten o'clock.

25. Explain how to obtain the error of a common watch by comparing it directly with a sidereal clock.

EXERCISES FOR ASTRONOMICAL MAPS.

29. Star-maps.

1. Given the right ascension and declination of the sun and moon, find their places on a star-map.

2. Show how to find the places of the sun and moon by means of celestial latitude and longitude.

3. Locate the bright planets for a given day, and see how they are placed with regard to bright stars.

4. The *Boston Herald* of Aug. 23, 1895, announced the discovery of a new comet at Echo Mountain, California, in right ascension $0^{\text{h}} 27^{\text{m}} 40^{\text{s}}$, and declination $+ 5^{\circ} 30'$. Find the position of the comet on the maps employed.

5. Given the right ascension and declination of a star, find it on a star-map.

6. Given a star, ascertain its right ascension and declination from the map.

7. Identify the stars γ , δ , ϵ , ζ , η , θ , ι , and κ in the constellation Orion on Map II of Newcomb's "Popular Astronomy."

8. Explain how double, multiple, and variable stars, nebulae, and star-clusters are designated on the maps used.

9. Find on Proctor's or Schurig's Atlas the letters or numbers for

five stars in Cetus which are marked but not named on Young's Uranography.

10. Having taken the right ascension and declination of a star from Young's Uranography, express the right ascension in degrees, and find it on Heis's Atlas.

11. Having taken the right ascension and declination of a star from Heis, express right ascension in time and find the star on Young's Uranography.

12. Compare the epoch of "Proctor's New Star Atlas" with the epoch of the *Bonn Durchmusterung*, and identify one of the stars of the catalogue on the Atlas.

13. Take the coördinates of a star from Porter's Cincinnati Catalogue for 1890, and identify it on one of the charts of the *Bonn Durchmusterung*.

30. Maps of the moon.

1. Find in what quadrant the following lunar objects are situated, and how they are placed with regard to the moon's equator and central meridian; Mare Crisium, Mare Serenitatis, Apennines, Alps, Tycho, Copernicus, Aristarchus, and Plato.

2. Ascertain the approximate latitude and longitude of the objects named above.

3. For a given age of the moon, find the longitude of the terminator and the principal formations through which it passes.

4. Ascertain at what age of the moon an observation should be made in order to see sunrise on Mt. Caucasus.

SUGGESTIONS AND ILLUSTRATIONS.

31. **Morning and evening stars.** — The bright planets are called morning or evening stars, according as they are on one side or the other of the sun. Thus, the inferior planets, Mercury and Venus, are morning stars from inferior to superior conjunction, and evening stars during the remainder of their synodic periods; and the outer planets, Mars, Jupiter, and Saturn, are morning stars from conjunction to opposition, and evening stars from opposition to conjunction.

32. Meridian altitude of heavenly bodies. — The meridian altitude of any heavenly body may be determined theoretically, when its declination and the latitude of the place are known.

EXAMPLE 1. — Find the altitude of the sun at apparent noon, Sept. 7, 1897, at Northampton, Mass.

For this date, the sun's declination, given on page 22 of the Old Farmer's Almanac, is $+5^{\circ}.8$. Since Northampton is in north latitude $42^{\circ}.3$, the zenith point of this place is $42^{\circ}.3$ north of the celestial equator measured on the meridian, and the complement of this angle, $47^{\circ}.7$, is the altitude of that point of the equator which is on the meridian. Having, then, the altitude of the equator on the meridian, and the sun's distance above the equator measured on the same circle, we see that the altitude of the sun must be the sum of the two, or $53^{\circ}.5$; or, in brief,

| | |
|---|----------------|
| Latitude of Northampton = declination of the zenith = | $42^{\circ}.3$ |
| Co-latitude of Northampton = | $47^{\circ}.7$ |
| Declination of the sun = | $+5^{\circ}.8$ |
| Altitude of the sun = | $53^{\circ}.5$ |

Exactly the same method applies in finding the meridian altitude of planets, and for stars the only difference is that the mean annual declination, in place of that for the day, is sufficiently accurate.

EXAMPLE 2. — Find the moon's altitude for Nov. 3, 1897, when on the meridian at Santa Fé, New Mexico.

Since the moon's motion is much more rapid than that of the sun, if the same degree of accuracy is required, it may be necessary to take out the value of the declination corresponding to the required time. The moon's time of southing, taken from the Ephemeris for the Washington meridian, is $7^{\text{h}} 52^{\text{m}}$, the correction for longitude (§ 43, b) gives the time of transit at Santa Fé, $7^{\text{h}} 56^{\text{m}}$, and as the longitude of this place is $7^{\text{h}} 4^{\text{m}}$ W. (Appendix E), the corresponding Greenwich time of south-

ing is $15^{\text{h}} 0^{\text{m}}$ (§ 35). For this time the moon's declination is $-3^{\circ}.8$, and arranging the work as above, we have:

$$\begin{array}{r} \text{Co-latitude of Santa Fé} = 54^{\circ}.3 \\ \text{Declination of the moon} = \underline{-3.8} \\ \text{Altitude of the moon} = 50.5 \end{array}$$

The result in this example is not changed by the tenth of a degree if the Washington time of southing is retained without correction for longitude.

33. Civil and astronomical days. — The civil day is the one commonly employed. It is reckoned from midnight to midnight, in periods of twelve hours, both midnight and noon being called twelve o'clock. The astronomical day is the one used in the American Ephemeris and other astronomical year books. Its hours are reckoned continuously up to twenty-four, beginning with zero at noon of the civil day, that is, the civil day is twelve hours old when the astronomical day of the same date begins with zero hours.

EXAMPLE. — Mars crossed the meridian of Washington, Oct. 19, 1898, at $17^{\text{h}} 55^{\text{m}}.6$; find the corresponding civil date.

Since the given astronomical day began at 12^{h} civil time, in order to reckon from the zero of that time 12^{h} must be added, giving October 19, $29^{\text{h}} 55^{\text{m}}.6$, or October 20, $5^{\text{h}} 55^{\text{m}}.6$, A.M., as the required civil date.

34. Connection between standard and local time. — Our standards of time are the sun and the stars. When the sun crosses the meridian of a place, it marks apparent or sun noon for that place. When the stars cross the meridian, they furnish the means for determining the instant at which an imaginary point, called the vernal equinox, is on the meridian, and that instant is sidereal or star noon for that place. Either from sun time or star time, but usually from the latter, is derived the time employed in all practical affairs of life. The noon of this mean

time is fixed by the transit across the meridian of a "fictitious" or "mean" sun. Whether this mean time is called local time or standard time depends upon whether its noon is fixed by the mean sun crossing the meridian of the place, or some other meridian arbitrarily chosen. Since the introduction of standard time in our country, five standard meridians are recognized — all west of Greenwich. They are those of 60° , 75° , 90° , 105° , and 120° . (See frontispiece.)

The difference between standard and local time at any place is the difference in time between its meridian and the standard meridian. Thus, the longitude of Nashville, Tenn., is $5^h 47^m$ west of Greenwich, the longitude of the standard meridian for the central time belt is 6^h W., and so standard time at this meridian is 13^m slower than local time. Think of two clocks in Nashville which are to be regulated to the two times. When the daily turning of the heavens brings the mean sun to the local meridian, one clock is set to mark local noon, and when this sun reaches the standard meridian of 90° , 13^m later, that instant the second clock is set for standard noon. The second clock must then be 13^m slower than the first. Therefore, to obtain local time for Nashville add 13^m to standard time. Since the longitude of this place is known to the fraction of a second, the correction, if desired, may be obtained with the same degree of accuracy, but the 13^m derived by taking longitude from a common map differs only about $0^m.2$ from the value derived by taking the exact longitude from the American Ephemeris.

If the given place is west instead of east of the standard meridian, a like course of reasoning applies. Lawrence, Kan., is in longitude $6^h 21^m$ W. It is then 21^m west of the standard meridian, whose longitude is 6^h W. Let us think of two clocks in that place which keep, respectively, local and standard time. When the mean sun is on the standard meridian, one clock shows 12^h standard time; and 21^m later, when the mean sun has come to the meridian of Lawrence, the other clock shows

12^h local time. Standard time is then 21^m faster than local time, and thus for Lawrence, Kan., 21^m must be subtracted from standard time in order to obtain local time. When local time is given and standard time required, opposite signs must be used in applying corrections for longitude.

35. General rules for passing from standard to local time, and vice versa. — If standard time is given and local time required, add the difference in longitude if the place is east, and subtract it if the place is west of its standard meridian. Conversely, if local time is given and standard time required, subtract the difference in longitude if the place is east, and add it if the place is west of its standard meridian. These rules may be generalized so as to come under the fundamental principle of longitude and time. Since standard time is the local time at a standard meridian, every individual case of passing from local to standard, or standard to local, merely requires that local time of one meridian shall be expressed in local time of another meridian. Thus, if local times at two meridians are given, the time of the eastern is expressed in time of the western by subtracting the difference in longitude from the eastern time, and the time of the western is expressed in time of the eastern by adding the difference in longitude to the western time.

36. Equation of time. — The difference in time between the true sun and the mean sun is called the equation of time. Its value at noon is given in the American Ephemeris for every day of the year, and for Greenwich the hourly variation is included. This variation when largest does not much exceed a second an hour, and in most naked-eye work the noon value at Washington may be taken without correction for any hour of the day, and for places several hours distant in longitude. In rigorous time problems, the equation of time must be computed to the fraction of a second (§ 50, Ex. 1).

EXAMPLE. — Find the local mean time of apparent noon at Boston and at San Francisco, Sept. 14, 1897.

Since the sun is itself the standard of time, the instant of its crossing any meridian fixes apparent noon for that place.

| | <small>Boston.</small> | <small>San Francisco.</small> |
|---|---------------------------------|---------------------------------|
| Apparent time of sun's transit, Sept. 14, | 12 ^h 00 ^m | 12 ^h 00 ^m |
| Equation of time, Sept. 14, | 4 .7 | 4 .7 |
| Local mean time of apparent noon, | 11 55 .3 | 11 55 .3 |

37. Standard time of apparent noon. — According to the preceding sections, apparent noon differs from mean noon by the equation of time, and mean noon from standard noon by the difference between the local and standard meridians. The makers of small almanacs usually give under “sun fast” and “sun slow” the equation of time taken to the nearest minute directly from the astronomical year books.

EXAMPLE. — Find the standard time of apparent noon at Nashville, Tenn., Nov. 30, 1897.

For this date Jayne's Almanac gives sun fast 11^m, that is, the true sun comes to the meridian and marks apparent noon 11^m before the transit of the mean sun. But since Nashville is 13^m east of its standard meridian, the mean sun comes to the local meridian 13^m before standard noon (§ 34). If, then, apparent noon comes 11^m before mean noon, and mean noon 13^m before standard noon, apparent noon comes 24^m before standard noon, or at 11^h 36^m standard time.

This illustration shows that when standard time is employed, the equation of time cannot be used directly in comparing the clock with the sun, and so it is more convenient if for sun fast, the difference between sun noon and standard noon is given, as in the Old Farmer's Almanac. Thus, by this almanac we know immediately that apparent noon at Boston on Nov. 30, 1897, comes 27^m before standard noon, since 27^m is the time given under sun fast for that date.

In this and other examples it is convenient to think of the

mean sun crossing different meridians. We must bear in mind, however, that it is an imaginary object, and that the instant it passes over any meridian is never observed directly, but must be obtained by calculation from the transits of stars or of the true sun.

38. Time of southing of heavenly bodies. — When the times of transit for the sun, moon, and planets have been computed for Washington, they are readily adapted to the whole country, so far as the needs of naked-eye observing are concerned.

Let us think of the sun in its daily journey crossing the 75th, 90th, 105th, and 120th meridians. Since these meridians are 15° apart, the successive times of transit are separated by intervals of an hour. But if apparent time is used, the instant of transit at each meridian must be $12^h 00^m$; nor do local mean times of southing differ perceptibly from one another, for they are obtained by combining with this apparent time the equation of time, which for the same date is practically the same (§ 36).

The sun appears to move among the stars at the rate of nearly a degree a day, the moon and planets have varying rates of motion on the celestial sphere, and so the intervals at which they precede or follow the sun in the daily rotation are subject to irregular changes. Mercury, the swiftest moving planet, may vary more than a minute in local times of transit between Washington and San Francisco. The variation is less for the other planets, but since the moon gains on the sun about 12° a day, the local mean time of its transit at San Francisco is 6^m , or 7^m later than that at Washington. By means of the hourly differences for longitude, local times of transit can be obtained with any desired degree of accuracy. Since the stars may be considered as fixed points on the celestial sphere, their sidereal time of meridian passage (§ 39) given for Washington is practically the same over the whole continent, and the differences in the corresponding mean local times at different meridians come

from the acceleration of sidereal on mean solar time, which is about 10^s an hour (§ 48).

The general conclusion follows that, with the exception of the moon, the local mean times of transit of the heavenly bodies mentioned differ only a minute or two between Maine and California. In order to find when these bodies cross different meridians by standard time, the local time of the Washington meridian must in each case be expressed in the standard time of the particular place.

EXAMPLE. — Find the hour and minute of standard time at which the sun and Venus cross the meridians of New York, New Orleans, and San Francisco on Sept. 14, 1897.

The required times for the sun are obtained as follows :

| | New York. | New Orleans. | San Francisco. |
|-------------------------------------|------------------------------------|------------------------------------|------------------------------------|
| Wash. M.T. of sun's transit, | 11 ^h 55 ^m .3 | 11 ^h 55 ^m .3 | 11 ^h 55 ^m .3 |
| Diff. bet. stand. and loc. merid's, | — 4 .1 | + 0 .2 | + 9 .7 |
| Standard time of sun's transit, | 11 51 .2 | 11 55 .5 | 12 5 .0 |

The Washington mean time of the transit of Venus is 21^h 37^m.2, September 13, astronomical date, and the corresponding civil date is September 14, 9^h 37^m.2 A.M. (§ 33). From the latter time, the standard times at the three places are derived by combining with it the differences between the local and standard meridians given above.

39. Connection between hour-angles and time.— Time and hour-angles are so closely related that before taking up the problem of finding when heavenly bodies rise and set, hour-angles themselves must be considered.

The hour-angle of the sun, we know, is apparent time, but to obtain time from any other heavenly body it is necessary to add its hour-angle to the corresponding right ascension. The sum is sidereal time at the instant when the hour-angle was determined. In order to make the latter statement clear, let us recall a few preliminary definitions.

The point from which hour-angles are reckoned is the upper intersection of the celestial equator with the meridian of the place; the hour-angle of any point on the sphere is the angular distance between the foot of its hour-circle and the foot of the meridian measured westward on the equator; and sidereal time is the hour-angle of the vernal equinox. Then it follows that when a star is on the meridian, its right ascension, that is, its angular distance from the vernal equinox measured eastward on the celestial equator, is equal to the hour-angle of the vernal equinox, or sidereal time.

If the star, instead of being on the meridian, has moved westward by an hour-angle of 10 or 15 hours, this angle must be added to that on the meridian in order to obtain the entire angular distance of the vernal equinox from the meridian.

It should be noted that if hour-angles are not reckoned continuously through 24 hours, east hour-angles should receive the negative sign.

The best graphic illustrations of time and hour-angles are obtained in actually using the celestial globe; but Fig. 8 may aid somewhat in obtaining a clear idea of their connection.

In this figure, let S be the intersection of the equator and meridian from

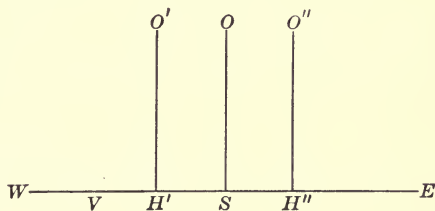

FIG. 8.

which hour-angles are reckoned, WE a section of the equator, V the vernal equinox, and O , O' , and O'' three stars on the meridian and on hour-circles west and east of the meridian.

The right ascension of O is VS , and since it is on the meridian, its hour-angle is zero, making the sum of right ascension and hour-angle VS , or sidereal time. The right ascension of O' is VH' , and as it is west of the meridian, its hour-angle is measured by the short arc SH' , and the sum of the two is VS . The right

ascension of O'' is VH'' , or $VS + SH''$; but its hour-angle is the large arc $SWEH''$. Designating it by $360^\circ - SH''$, the sum of right ascension and hour-angle is

$$VS + SH'' + 360^\circ - SH'' = VS.$$

In dealing with an hour-angle as large as this, it is simpler to treat it as an east hour-angle. We have then

$$VS + SH'' + (-SH'') = VS.$$

We conclude, therefore, that whether a star is east or west of the meridian, sidereal time is obtained by adding together its hour-angle and right ascension.

40. Formulæ for computing hour-angles.—The hour-angle of any heavenly body can be computed from the following formulæ, although for the moon a correction for parallax is usually required (§§ 136, 145).

Equations numbered (3) and (6) may be found in almost any treatise on astronomy; but with one exception the four are given here in the form employed in Articles 10, 20, and 145, Vol. I, of Chauvenet's "Astronomy." The one change is in deriving (4) from (1), (2), and (3), Art. 10, by putting $h = 0$:

$$\cos t = -\tan \phi \tan \delta \quad (3)$$

$$\left. \begin{aligned} \sin \delta &= -\cos \phi \cos A \\ \cos t &= \sin \phi \cos A \sec \delta \\ \sin t &= \sin A \sec \delta \end{aligned} \right\} \quad (4)$$

$$\left. \begin{aligned} m \cos M &= \cos \zeta \\ \tan M &= \tan \zeta \cos A \\ \tan t &= \frac{\tan A \sin M}{\cos(\phi - M)} \\ \tan \delta &= \tan(\phi - M) \cos t \end{aligned} \right\} \quad (5)$$

$$\sin \frac{1}{2} t = \sqrt{\frac{\sin \frac{1}{2} [\zeta + (\phi - \delta)] \sin \frac{1}{2} [\zeta - (\phi - \delta)]}{\cos \phi \cos \delta}} \quad (6)$$

While in formula (5) it is not necessary to find δ in order to

obtain t , the last equation is added since the value of δ gives a good check on the observation.

In all these formulæ, t is the hour-angle required, ϕ the latitude of the place, δ the declination of the body, and A and ζ its azimuth and zenith distance.

The quadrants in which angles lie, especially in (5), must receive attention. The auxiliary M should be taken in the quadrant determined by the algebraic signs of $\cos M$ and $\tan M$, m being a positive number. If the tangent of t is positive, t lies in the first or third quadrant; if the tangent is negative, t is to be taken in the second or fourth quadrant; and in each case the value of A decides between the two, for an hour-angle and the corresponding azimuth must be on the same side of the meridian.

An examination of the different formulæ shows that (3) and (6) may be employed to find a purely theoretical hour-angle, while (4) requires an observed azimuth, and (5) both altitude and azimuth from observation. The last two are adapted to any zenith distance; and all but (5) may be applied to bodies on the horizon, though the last is more accurate than the first for theoretical values. Thus, if a body has appreciable diameter, the zenith distance of its centre at apparent rising or setting is equal to $90^\circ + r + s$, where r is the refraction on the horizon and s the semi-diameter of the body. Taking $16'$ as the mean semi-diameter of the sun, and $36'.5$ as refraction on the horizon (Chauvenet's "Astronomy," Table I), we have then:

$$\zeta = 90^\circ + 36'.5 + 16', \text{ or } 90^\circ 52'.5.$$

If tables of semi-diurnal arcs have been computed, the approximate hour-angle of a heavenly body when on the horizon can be taken out directly with arguments of latitude and declination.

41. Effects of longitude and latitude on hour-angles.—The only sensible effect of longitude upon an hour-angle comes from changes in declination; for since declination varies with the

time, its value for a given body will vary for places differing in longitude. The amount of variation, if we neglect the moon (§ 38), has a maximum value of about 2'.2 an hour for Mercury, and is practically zero for the stars.

EXAMPLE 1. — Find the hour-angle of the sun when rising, Nov. 5, 1897, at Philadelphia, and at a place having the same latitude, but lying 3 hours farther west in longitude.

The latitude of Philadelphia is $+39^{\circ} 57'$ (Appendix E). The sun's declination for Washington apparent noon for the given date is $-15^{\circ} 56'$, and this value is sufficiently accurate for the corresponding noon at Philadelphia, as the difference in longitude is less than 10 minutes. From the celestial globe we see that the sun rises at Philadelphia, on this day, about 5 hours before noon (§ 80), and since its hourly motion in declination is $-45''.1$, the correction is $-3'.8$, which must be subtracted algebraically from the noon value of δ , as this quantity is numerically less at sunrise than at noon, making δ at the required time $-15^{\circ} 52'$, to the nearest minute. The corresponding value for ζ is $90^{\circ} 52'$ (§ 40), and the hour-angle is computed as follows:

| | | |
|---|---------------------------------------|--------------------|
| $\phi = +39^{\circ} 57'$ | $\log \sec \phi$ | = 0.11543 |
| $\delta = -15 52$ | $\log \sec \delta$ | = 0.01687 |
| $\phi - \delta = \underline{55 49}$ | $\log \sin \frac{1}{2} \text{ sum}$ | = 9.98136 |
| $\zeta = \underline{90 52}$ | $\log \sin \frac{1}{2} \text{ diff.}$ | = 9.47894 |
| $\frac{1}{2} \text{ sum} = \underline{73 20}$ | | <u>19.59260</u> |
| $\frac{1}{2} \text{ diff.} = \underline{17 32}$ | $\log \sin \frac{1}{2} t$ | = 9.79630 |
| $t = \underline{77 28}$ | $\frac{1}{2} t$ | = $38^{\circ} 44'$ |

The sun's hour-angle at rising, therefore, equals $-5^{\text{h}} 9^{\text{m}}.9$.

For the second part of the problem ζ and ϕ are the same as at Philadelphia; but 3 hours west of this place, that is, 3 hours later, the declination must be numerically greater, since in the given month the sun's south declination is increasing. Thus, $-15^{\circ} 52' - 2'$, or $-15^{\circ} 54'$, is the required value of δ , and the hour-angle calculated as above is found to be $-5^{\text{h}} 9^{\text{m}}.5$.

Since ϕ enters directly into the formulæ for finding hour-

angles, differences in latitude cause far larger variations in the time of rising of heavenly bodies than differences in longitude.

EXAMPLE 2. — Find the hour-angle of the sun when rising Nov. 5, 1897, at Northfield, Minn., and Oxford, Miss.

The preceding example shows that a difference of several hours in longitude has so small an effect upon declination and hour-angle, that for both places given here, we may use without change the noon value of the declination at Washington.

Taking the latitude of Northfield $44^{\circ} 28'$, and that of Oxford $34^{\circ} 22'$, we find the required hour-angle for the northern station to be $-5^{\text{h}} 0^{\text{m}}.1$, and for the southern station, $-5^{\text{h}} 19^{\text{m}}.3$. Thus we see that while a change of 45° in longitude may affect the hour-angle less than half a minute, it is possible for a difference of 10° in latitude to change the hour-angle by 19 minutes.

42. Times of rising of heavenly bodies. — Whether we deal with the rising or setting of heavenly bodies, the same reasoning applies, so only the former need be considered.

The apparent time of sunrise is the sun's hour-angle when the sun is on the horizon. The sidereal time of the rising of comets, planets, and stars is their hour-angle when on the horizon, added to their right ascension (§ 39).

In case of the sun, differences in times of rising depend simply upon differences in hour-angles. Thus, the four hour-angles of the sun obtained in the preceding section for Nov. 7, 1897, are reduced to mean local time by applying the same equation of time (§ 36).

For Philadelphia we have :

| | |
|-----------------------------|--------------------------------|
| Sun's hour-angle at rising, | $-5^{\text{h}} 9^{\text{m}}.9$ |
| Apparent noon, | $12 0 .0$ |
| Apparent time of sunrise, | $6 50 .1$ |
| Equation of time, | $16 .3$ |
| Local mean time of sunrise, | $5 33 .8$ |

In like manner, for a place 3 hours farther west on the same parallel of latitude, we find the time of sunrise to be $5^{\text{h}} 34^{\text{m}}.2$ A.M. Whence it appears that the time when the sun rises changes slightly as long as the latitude remains the same.

If, however, the times of sunrise are determined for Northfield and Oxford (§ 41), they are found to be $6^{\text{h}} 44^{\text{m}}$ A.M., and $6^{\text{h}} 24^{\text{m}}$ A.M., making the time about 20^{m} earlier at the station 10° farther south in latitude.

Hour-angles of planets and stars should be subject to the same conditions of change which affect the sun's hour-angle, and in addition the right ascension must be considered. For stars, this factor may be treated as a constant by naked-eye observers, and for Mercury, the swiftest moving planet, the variation in right ascension does not often exceed a minute and a half in 3 or 4 hours.

If, then, places are taken on the same parallel of latitude, we are warranted in drawing the conclusion that the sun, planets, and stars rise and set within 2 or 3 minutes of the same local mean time at all points in our country between the Atlantic and Pacific.

The makers of small almanacs take advantage of the slight effect of right ascension and declination upon the times of rising of the sun and other heavenly bodies, and usually make the necessary calculations for a single meridian in a section with a wide extent in longitude and a comparatively small variation in latitude. When standard time is employed, tabular corrections may be added for different meridians.

43. Tabular corrections for the Old Farmer's Almanac. — a) *Sun fast.* The quantity called sun fast in the Old Farmer's Almanac, as already stated, is the difference between apparent and standard noon. According to the method employed in finding sun fast for Nashville (§ 37), we have for Nov. 30, 1897:

| | Boston. | Keene, N. H. | Augusta, Me. |
|---|---------------------------------|---------------------------------|---------------------------------|
| Apparent noon, | 12 ^h 00 ^m | 12 ^h 00 ^m | 12 ^h 00 ^m |
| Equation of time, | 11 | 11 | 11 |
| Diff. between 75th and local meridians, | <u>- 16</u> | <u>- 11</u> | <u>- 21</u> |
| Standard time of apparent noon, | 11 33 | 11 38 | 11 28 |
| Sun fast, | 27 | 22 | 32 |

The value 22^m, sun fast for Keene, agrees exactly with that obtained by subtracting 5^m, the difference in longitude between Boston and Keene, from 27^m, sun fast for Boston. And this is reasonable, for the problem is precisely the same as for Boston, except that at Keene the difference between the local and the standard meridians is 5^m less. This difference is 5^m greater at Augusta, Me., and for that place 5^m must be added to the Boston value. For other places in New England, sun fast may be obtained in like manner directly from the Boston value by subtracting the difference in longitude if the place is west and adding it if it is east of Boston.

b) *Moon's time of transit.* In a small section like New England, the time at which the moon souths on the same day at different places varies only a minute or two from the time at Boston, provided local mean time is employed (§ 38).

EXAMPLE 1. — Having obtained the local mean time of the moon's transit at Boston for Dec. 7, 1897, find the standard time of transit at Boston, Biddeford, Me., and Hartford, Conn.

On this date the moon crossed the meridian at Washington at 11^h 1^m P.M., and the difference in time of transit for one hour of longitude is 2^m.1. Since Boston is 0^h.4 east of Washington, 0^m.8 is the correction to be subtracted from the Washington time of transit to obtain that of Boston, and this is also very nearly the local time at the other two places as their longitude from Boston is only a few minutes. We have then:

| | Hartford. | Boston. | Biddeford. |
|---|--------------------------------|--------------------------------|--------------------------------|
| Local mean time of transit, | 11 ^h 0 ^m | 11 ^h 0 ^m | 11 ^h 0 ^m |
| Diff. between 75th and local meridians, | <u>- 9</u> | <u>- 16</u> | <u>- 18</u> |
| Standard time of transit, | 10 51 | 10 44 | 10 42 |

The correction subtracted to find standard time at Boston is 7^m greater than at Hartford, and so standard time at Hartford may be found by adding 7^m to that of Boston. On the other hand, the correction subtracted at Boston is 2^m smaller than at Biddeford, and at the latter place the standard time of transit is found by subtracting 2^m from the Boston time. In general, the difference in longitude is added if the place is west of Boston, but subtracted if it is east.

c) *Rising of sun, moon, and planets.* The local times at which the sun and planets rise are practically the same for all places in New England with the same latitude, and a variation of 2° or 3° in latitude will not introduce any large difference in the times (§ 42).

EXAMPLE 2. — The local time of sunrise at Boston, Dec. 21, 1897, is $7^h 27^m$ A.M.; find the corresponding standard times at Boston, Brattleboro, Vt., and Portland, Me., assuming that the local time is the same for the three places.

This problem, like the one preceding, consists in converting the local time common to the three places into the time of the 75th meridian. Arranging the work as usual, we have:

| | Brattleboro. | Boston. | Portland. |
|---|--------------------------|--------------------------|-------------------------|
| Local mean time of sunrise, | $7^h 27^m$ | $7^h 27^m$ | $7^h 27^m$ |
| Diff. between 75th and local meridians, | -10 | -16 | -19 |
| Standard time of sunrise, | <u>$7 17$</u> | <u>$7 11$</u> | <u>$7 8$</u> |

The required times at Brattleboro and Portland may be found directly from the Boston time. As Brattleboro is 6^m west of Boston, the correction subtracted there is 6^m too large for Brattleboro, so for that place 6^m must be added to $7^h 11^m$. The correction subtracted for Boston is 3^m too small for Portland, and standard time of sunrise there is 3^m less than $7^h 11^m$. The general rule for corrections is, then, the same as for transits — add differences in longitude for places west of Boston and subtract for places east of Boston. The time at which the moon rises at almost any place in New England may be found accu-

rately enough for purposes of practical life by correcting the Boston times of moonrise in the same manner as those for the sun and planets.

44. Sun's coördinates for any meridian. — When the interval is less than a day, changes in the right ascension and declination of the sun are nearly proportional to the time. To find these coördinates when the sun crosses the meridian of a given place it is only necessary to combine with the values for Greenwich apparent noon the corrections obtained by multiplying the hourly differences, found in the Ephemeris, by the difference in longitude between Greenwich and the given place.

EXAMPLE. — From the right ascension and declination of the sun at Greenwich apparent noon, June 18, 1898, find the value of these coördinates when the sun crosses the meridian of the Columbia Observatory, Missouri, whose longitude is $6^h 9^m 18^s.33$ W.

| | | | |
|---------------------------|--|---------------------|----------------------|
| R. A. for Gr. app. noon = | 5 ^h 47 ^m 50 ^s .68 | Hourly diff. = + | 10 ^s .403 |
| Corr. for longitude = | + 1 4.03 | $6^h 9^m 18^s.33 =$ | 6.155 |
| R. A. for Columbia = | 5 48 54.71 | | + 64.03 |
| Decl. for Gr. app. noon = | + 23° 25' 25".4 | Hourly diff. = + | 3".02 |
| Corr. for longitude = | + 18 .6 | | 6.155 |
| Decl. for Columbia = | + 23 25 44 .0 | | + 18.6 |

In a similar manner the right ascension and declination of the moon and planets may be found for different meridians.

45. Moon's age and time of southing. — In an old encyclopædia* the following rule is given for finding the approximate time of the moon's southing: "Multiply her age by 4 and divide the product by 5; the quotient gives the hour, and the remainder, multiplied by 12, the minute."

EXAMPLE. — Jayne's Almanac gives the time of new moon

* "The Cyclopædia," by Abraham Rees and other eminent professional gentlemen. First American Edition, 1810-1824.

at 0^h.8 P.M., Dec. 4, 1896, at Philadelphia; required the approximate time of southing on the 17th.

In order to fix the moon's age approximately on December 17, some hour of southing for that date must be assumed. Since full moon comes on the 19th, and since a full moon crosses the meridian about midnight, its transit two days earlier cannot come after midnight, and so it is fair to assume midnight as the time of southing, making the astronomical date 17^d 12^h. If we subtract from this time the number of days and hours when the moon was new, the remainder, 13^d 11^h.2, is the approximate age of the moon when it souths on the 17th. Multiplying and dividing according to the rule, the time of transit which we obtain is 10^h 47^m P.M. With this more accurate time a second approximation gives 10^h 44^m, and this value, since the change is so slight, may be considered correct within the limits of the method. If no thought is given to full moon and the unfavorable supposition made that southing comes at six o'clock in the evening, nearly the same result is obtained:

| | |
|---------------------------|---------------------------------|
| Assumed time of southing, | 17 ^d 6 ^h |
| Time of new moon, | 4 0 .8 |
| Moon's age at southing, | 13 5 .2 |
| Time of southing, | 10 ^h 34 ^m |

By repeating the operation, the time found is 10^h 43^m P.M. These times are about half an hour late, but five days earlier in the same month the time of southing derived by this method is in error only about three minutes.

46. Time of moon's phases. — Changes in the phases of the moon do not in any way depend upon the place of observation. They occur everywhere at the same absolute instant of time. If then, the phases have been computed for any meridian, the almanac maker has only to find the corresponding times for the reference meridian of the particular almanac. The American

Ephemeris gives the times of all the phases for both the Greenwich and Washington meridians. The former are perhaps more convenient, since fewer changes in sign are involved in passing to different meridians.

In taking out the Ephemeris times required for most of the examples which follow in this chapter, it must be borne in mind that the day of the Ephemeris is the astronomical day (§ 33); and when this day is employed local time is commonly used in the reduction, and standard time derived only as a final step.

EXAMPLE 1. — For the month of December, 1897, the following dates are given for the phases of the moon at Greenwich:

| | |
|----------------|---|
| Full moon, | Dec. 8 ^d 16 ^h 54 ^m .4. |
| Last quarter, | “ 16 16 21 .9. |
| New moon, | “ 23 7 55 .2. |
| First quarter, | “ 30 7 26 .7. |

Find the local times of these phases for the same month at Philadelphia.

For the first phase, we have:

| | |
|---|--|
| Greenwich time of full moon, | Dec. 8 ^d 16 ^h 54 ^m .4 |
| Philadelphia west of Greenwich, | <u>5 0 .6</u> |
| Full moon at Philadelphia, | 8 11 53 .8 |
| Civil date for full moon at Philadelphia, | 8 11 53 .8 P.M. |

In like manner the phases for the other dates may be found.

EXAMPLE 2. — Taking the Greenwich time of the last quarter given in the preceding example, find when this phase occurs in Central, Mountain, and Pacific time.

Since the standard meridians for these time belts are respectively 6^h, 7^h, and 8^h west of Greenwich, we have only to subtract these numbers from the given Greenwich time:

| | | | |
|--|---------------------------------|---------------------------------|---------------------------------|
| Greenwich time of last quarter, Dec. 16, | 16 ^h 22 ^m | 16 ^h 22 ^m | 16 ^h 22 ^m |
| Standard meridians west of Gr., | <u>6</u> | <u>7</u> | <u>8</u> |
| Standard times of last quarter, Dec. 16, | 10 22 | 9 22 | 8 22 |

For any given place, standard time may be obtained by finding first the local time of the phase, and then passing to standard time.

EXAMPLE 3. — Find the standard time of the moon's last quarter in December, 1897, at Omaha, Neb.

Placing the work in tabular form, we have:

| | |
|--|----------------------------------|
| Greenwich time of last quarter, Dec. 16, | 16 ^h 22 ^m |
| Omaha west of Greenwich, | 6 24 |
| Local time of last quarter, | <hr style="width: 100%;"/> 9 58 |
| Omaha west of 90th meridian, | 24 |
| Standard time of last quarter at Omaha, Dec. 16, | <hr style="width: 100%;"/> 10 22 |

As Omaha is in the central time belt, this result agrees with the first value found in Example 2.

EXAMPLE 4. — For December, 1897, find the hour and minute of last quarter, both for the Old Farmer's Almanac and for Jayne's Almanac.

| | Old Farmer's. | Jayne's. |
|--|-------------------------------------|-------------------------------------|
| Greenwich time of last quarter, Dec. 16, | 16 ^h 21 ^m .9 | 16 ^h 21 ^m .9 |
| Reference meridians west of Gr., | 5 | 4 44 .2 |
| Almanac times of last quarter, Dec. 16, | <hr style="width: 100%;"/> 11 21 .9 | <hr style="width: 100%;"/> 11 37 .7 |

The time for the Old Farmer's Almanac corresponding to the Greenwich time is obtained by subtracting 5^h, since the meridian employed for this almanac is 5^h west of Greenwich. Jayne's Almanac is, however, adapted to local time, and the correction to be subtracted is the longitude of Boston, 4^h 44^m.2 W. The difference in the time of the phase in the two almanacs is accounted for by the fact that one is computed for standard time, the other for local time. If the standard time of the Old Farmer's Almanac is reduced to local time by adding 15^m.8, Boston's longitude east of the standard meridian, the resulting value, 11^h 37^m.7, agrees with that given in Jayne's Almanac.

In Examples 2, 3, and 4 no correction is needed to reduce to civil time except to write P.M. after the final hours and minutes (§ 33).

47. Phases of a lunar eclipse. — The instant at which the moon enters or leaves the earth's shadow is the same wherever the eclipse is seen, and consequently the time of the phase having been computed for Greenwich, the corresponding time at any local or standard meridian may be found by applying the correction for longitude (Young, Art. 378, E. Art. 233, see Preface).

EXAMPLE 1. — Find the eastern standard time for the beginning and ending of the partial lunar eclipse of January, 1898.

The Greenwich time at which the moon enters the earth's shadow is $7^d 11^h 47^m.5$, the eastern standard time obtained by subtracting 5^h is $7^d 6^h 47^m.5$ P.M. In like manner from the Greenwich time $13^h 23^m.0$, at which the moon leaves the shadow, the end of the eclipse in eastern standard time is found to be $8^h 23^m.0$ P.M.

EXAMPLE 2. — For the same eclipse as above, find the local time of beginning and ending at Baltimore.

| | Moon enters shadow. | Moon leaves shadow. |
|------------------------------|------------------------|------------------------|
| Greenwich time, Jan. 7, | $11^h 47^m.5$ | $13^h 23^m.0$ |
| Baltimore west of Greenwich, | $5 \quad 6 \quad .4$ | $5 \quad 6 \quad .4$ |
| Local time at Baltimore, | $6 \quad 41 \quad .1$ | $8 \quad 16 \quad .6$ |

48. Sidereal and mean time intervals. — At the end of the American Ephemeris two tables are given, one of which is designated "TABLE II. — SIDEREAL INTO MEAN SOLAR TIME"; the other, "TABLE III. — MEAN SOLAR INTO SIDEREAL TIME." In each, the corrections are taken out directly for hours and minutes, and a separate column gives the corrections for seconds.

EXAMPLE 1. — Given the mean time interval $20^h 17^m 55^s.4$; required the equivalent sidereal interval.

| | |
|---------------------------------------|------------------------------------|
| Mean time interval | $= 20^h 17^m 55^s.4$ |
| Table III, correction for $20^h 17^m$ | $= +3 \quad 19 \quad .92$ |
| “ “ “ “ $55^s.4$ | $= \quad \quad + 0 \quad .15$ |
| Sidereal interval | $= 20 \quad 21 \quad 15 \quad .47$ |

EXAMPLE 2. — Given the sidereal interval $18^{\text{h}} 15^{\text{m}} 51^{\text{s}}.42$; required the equivalent mean time interval.

| | |
|--|--|
| Sidereal time interval | = $18^{\text{h}} 15^{\text{m}} 51^{\text{s}}.42$ |
| Table II, correction for $18^{\text{h}} 15^{\text{m}}$ | = $- 2 \quad 59.39$ |
| “ “ “ “ $51^{\text{s}}.42$ | = $\quad \quad - 0.14$ |
| Mean time interval | = $18 \quad 12 \quad 51.89$ |

Since in 24^{h} of mean solar time the sidereal time gains $3^{\text{m}} 56^{\text{s}}.556$ on mean solar time, its gain in one hour is $9^{\text{s}}.856$. In 24^{h} of sidereal time, on the other hand, mean solar time loses $3^{\text{m}} 55^{\text{s}}.909$ on sidereal time, or $9^{\text{s}}.830$ in one hour (Chauvenet's "Astronomy," Vol. I, Arts. 49, 50). If the tables are not at hand, therefore, the corrections given above may be obtained by multiplying the number of seconds by the interval expressed in hours.

49. Standard time reduced to local and Greenwich time. — The problem of converting the time of one meridian into that of another has been considered in Section 34, and fully illustrated in this chapter. The only object in adding anything further is to present in orderly sequence the principal problems in time. The general method employed is that rendered classic by Chauvenet, and for a complete discussion of the subject of time the student is referred to that author's treatise on "Spherical and Practical Astronomy," Vol. I, Chap. II.

EXAMPLE 1. — At Amherst, Mass., in longitude $4^{\text{h}} 50^{\text{m}} 4^{\text{s}}.67$ W., given standard time $11^{\text{h}} 23^{\text{m}} 57^{\text{s}}.0$ A.M., March 17, 1898; required the corresponding local astronomical time.

| | |
|------------------------------------|--|
| Standard time, March 17, | 11 ^h 23 ^m 57 ^s .0 |
| Amherst east of 75th meridian, | <u>9 55.33</u> |
| Local time, | 11 33 52.33 |
| Local astronomical time, March 16, | 23 33 52.33 |

EXAMPLE 2. — At Ann Arbor, Mich., in longitude $5^{\text{h}} 34^{\text{m}} 55^{\text{s}}.19$ W., Oct. 23, 1898, given standard time $9^{\text{h}} 13^{\text{m}} 16^{\text{s}}$ P.M.; required the corresponding Greenwich time.

The standard time at Ann Arbor is the local time of the 90th meridian.

| | |
|--|--|
| Astronomical time at 90th meridian, Oct. 23, | 9 ^h 13 ^m 16 ^s |
| 90th meridian west of Greenwich, | 6 |
| Greenwich time, Oct. 23, | <u>15 13 16</u> |

This result is the same as that obtained by first reducing the standard time at Ann Arbor to local time, and then to Greenwich time.

50. Standard time reduced to apparent time. — After standard time has been reduced to local time (§ 49), apparent time is derived by means of the equation of time (§ 36). Since hourly differences for this quantity are given only for the Greenwich meridian, the natural order is to find the Greenwich time corresponding to the given mean time, take out the equation of time for Greenwich mean noon of that day and the hourly difference immediately following. The equation of time for the particular hour and minute required is then found by combining with the noon value the correction obtained by multiplying this difference by the time since noon, expressed in hours. The resulting value is the equation of time for the given Greenwich instant, and it is also the value for the local time corresponding to that instant.

EXAMPLE 1. — In longitude 6^h 59^m 47^s.63 W., required the equation of time at 9^h 18^m 53^s.37 A.M., local mean time, June 11, 1898.

| | |
|------------------------------|---|
| Astronomical time, June 10, | 21 ^h 18 ^m 53 ^s .37 |
| Longitude west of Greenwich, | <u>6 59 47.63</u> |
| Greenwich time, June 11, | 4 18 41.00 |

Letting E stand for equation of time, we have:

| | | | |
|---|-----------------------|--|------------------------|
| For Greenwich mean noon, E | = 37 ^s .62 | Hourly diff. | = -0 ^s .504 |
| Correction for 4 ^h 18 ^m 41 ^s .00 | = -2.17 | 4 ^h 18 ^m 41 ^s .00 | = <u>4.311</u> |
| For June 11, 4 18 41.00, E | = 35.45 | | - 2.17 |

EXAMPLE 2. — At Denver, Col., in longitude $6^{\text{h}} 59^{\text{m}} 47^{\text{s}}.63$ W., June 11, 1898, given standard time $9^{\text{h}} 18^{\text{m}} 41^{\text{s}}.0$ A.M.; required the corresponding apparent time.

| | |
|--|---|
| Standard time at Denver, | 9 ^h 18 ^m 41 ^s .0 |
| Denver east of 105 th meridian, | 12.37 |
| Local mean time, | 9 18 53.37 |
| Equation of time, | 35.45 |
| Apparent time at Denver, | 9 19 28.82 |

51. **Mean time reduced to sidereal time.** — The American Ephemeris gives for every day of the year, on p. II of each month, the sidereal time of Greenwich mean noon; and at any other hour at Greenwich the corresponding sidereal time is found by combining with the noon value the interval before or after noon, corrected for the acceleration of sidereal time (§ 48). To find sidereal time at any other place the following method may be employed.

Reduce the given mean time to Greenwich time, convert it into sidereal time, and then find the corresponding local sidereal time by means of the longitude, which may be reckoned in sidereal as well as in mean time.

EXAMPLE 1. — Given the mean time at Greenwich, Apr. 3, 1898, $1^{\text{h}} 13^{\text{m}} 29^{\text{s}}$; find the corresponding sidereal time.

| | |
|--|--|
| Greenwich mean time, Apr. 3, | 1 ^h 13 ^m 29 ^s |
| Corr. to reduce $1^{\text{h}} 13^{\text{m}} 29^{\text{s}}$ to sidereal time, | + 12.07 |
| Sidereal time at Greenwich mean noon, | 0 47 20.99 |
| Greenwich sidereal time, | 2 1 2.06 |

EXAMPLE 2. — At Poughkeepsie, in longitude $4^{\text{h}} 55^{\text{m}} 33^{\text{s}}.6$, given local mean time $8^{\text{h}} 17^{\text{m}} 55^{\text{s}}.40$ A.M., Apr. 3, 1898; required the corresponding sidereal time.

| | | |
|---|---|-----|
| Local mean time, ast. date, Apr. 2, | 20 ^h 17 ^m 55 ^s .40 | (1) |
| Longitude of Poughkeepsie, W. of Gr., | 4 55 33.6 | (2) |
| Corres. mean time at Greenwich, Apr. 3, | 1 13 29.00 | |

| | | |
|--|--------------------------------------|-----|
| Corr. to reduce $1^{\text{h}} 13^{\text{m}} 29^{\text{s}}$ to sidereal time, | + 12 ^s .07 | (3) |
| Sidereal time of Greenwich mean noon, | 0 ^h 47 ^m 20.99 | (4) |
| Required sidereal time at Greenwich, | <u>2 1 2.06</u> | |
| Longitude of Poughkeepsie, W. of Gr., | 4 55 33.6 | (5) |
| Sidereal time at Poughkeepsie, Apr. 2, | <u>21 5 28.46</u> | |

In the above operation five quantities are combined, but two of them are the longitude of Poughkeepsie, which is first added and then subtracted, so exactly the same result is obtained by omitting the longitude and combining the remaining quantities. The Greenwich time must, however, be known in order to find the correction 12^s.07.

| | | |
|--|---|-----|
| Local mean time, ast. date, Apr. 2, | 20 ^h 17 ^m 55 ^s .40 | (1) |
| Corr. to reduce $1^{\text{h}} 13^{\text{m}} 29^{\text{s}}$ to sidereal time, | + 12.07 | (3) |
| Sidereal time of Greenwich mean noon, | 0 47 20.99 | (4) |
| Sidereal time at Poughkeepsie, Apr. 2, | <u>21 5 28.46</u> | |

It is not necessary, as in this example, to find Greenwich time in reducing mean to sidereal time. Knowing the sidereal time at Greenwich mean noon, we can find the sidereal time corresponding to the mean noon of any place, just as it is found for several hours before or after noon at Greenwich, for the same principle is involved in finding the acceleration for the noon of a place an hour west in longitude as for an hour after noon at Greenwich.

Solving the example given above according to this method, we have :

| | |
|---|--|
| Sidereal time of Greenwich mean noon, | 0 ^h 43 ^m 24 ^s .44 |
| Acceleration for longitude $4^{\text{h}} 55^{\text{m}} 33^{\text{s}}.6$ W., | <u>+ 48.55</u> |
| Sidereal time of mean noon at Poughkeepsie, | 0 44 12.99 |
| Mean time interval since mean noon, | 20 17 55.40 |
| Corr. to reduce 20 ^h 17 ^m 55 ^s .40 to sider. time, | <u>+ 3 20.07</u> |
| Sidereal time at Poughkeepsie, | <u>21 5 28.46</u> |

In practice the four quantities may be added directly without finding explicitly the sidereal time of local mean noon.

52. Sidereal time reduced to mean time. — In order to convert sidereal into mean time it is necessary to pass from the zero of one time to the zero of the other. For this purpose we may employ the sidereal time of mean noon or the mean time of sidereal noon.

EXAMPLE. — At St. Louis, Mo., in longitude $6^{\text{h}} 0^{\text{m}} 49^{\text{s}}.11$, given the sidereal time $18^{\text{h}} 15^{\text{m}} 51^{\text{s}}.42$, Nov. 15, 1898; find the corresponding mean time.

The sidereal time at Greenwich corresponding to the given sidereal time is $24^{\text{h}} 16^{\text{m}} 40^{\text{s}}.53$, but since mean noon comes there at $15^{\text{h}} 38^{\text{m}} 22^{\text{s}}.53$ sidereal time (Ephemeris, p. II for November), the sidereal interval since mean noon is the difference between the two, or $8^{\text{h}} 38^{\text{m}} 18^{\text{s}}.00$, and this becomes mean time as soon as the correction $-1^{\text{m}} 24^{\text{s}}.91$ from Table II of the Ephemeris is applied. Therefore $8^{\text{h}} 36^{\text{m}} 53^{\text{s}}.09$ is the Greenwich mean time corresponding to the required local time, and the two differ only by the longitude between the two places, so the required local mean time is $2^{\text{h}} 36^{\text{m}} 3^{\text{s}}.98$.

Bringing the different operations together, we have:

| | |
|--|--|
| Local sidereal time, | $18^{\text{h}} 15^{\text{m}} 51^{\text{s}}.42$ |
| St. Louis west of Greenwich, | <u>6 0 49.11</u> |
| Corres. sidereal time at Greenwich, | <u>24 16 40.53</u> |
| Sidereal time of Greenwich mean noon, | <u>15 38 22.53</u> |
| Sidereal interval after Gr. mean noon, | 8 38 18.00 |
| Corr. to reduce $8^{\text{h}} 38^{\text{m}} 18^{\text{s}}$ to mean time, | <u>- 1 24.91</u> |
| Required mean time at Greenwich, | <u>8 36 53.09</u> |
| St. Louis, west of Greenwich, | <u>6 0 49.11</u> |
| Local mean time, | 2 36 3.98 |

In practice this operation may be considerably shortened. Instead of passing to Greenwich and then back to St. Louis time by adding and subtracting the longitude, the same result is obtained if the sidereal time of Greenwich mean noon is subtracted directly from the given sidereal time. Since this sidereal interval is shorter than the corresponding one at Green-

wich by the difference in longitude between the two places, it is necessary to apply not only a correction to reduce this interval to mean time, but a like correction for the hours and minutes of longitude. The sum of the two corrections is equal to the one given above.

| | |
|--|---|
| Local sidereal time, Nov. 15, 1898, | 18 ^h 15 ^m 51 ^s .42 |
| Sidereal time of Greenwich mean noon, | 15 38 22.53 |
| Sidereal interval, | <u>2 37 28.89</u> |
| Corr. to reduce 2 ^h 37 ^m 28 ^s .89 to mean time, | — 25.80 |
| Corr. to reduce 6 ^h 0 ^m 49 ^s .11 to mean time, | — 59.11 |
| Local mean time, | <u>2 36 3.98</u> |

The sum of the two corrections is $-1^m 24^s.91$, which agrees with the single correction in the first solution.

The same example may be taken to illustrate another method of finding mean time; and here again the first step is to obtain the sidereal time at Greenwich corresponding to that given. The interval elapsed since the latest sidereal noon there is $16^m 40^s.53$, and this reduced to a mean time interval is $16^m 37^s.80$. But at sidereal noon, the mean time is $8^h 20^m 15^s.29$ (Ephemeris, p. III for November). Knowing, then, the mean time at sidereal noon and the mean time since that noon, we add the two in order to obtain the Greenwich mean time, and the corresponding local time is found as usual.

The work in full is as follows:

| | |
|--|---|
| Local sidereal time, | 18 ^h 15 ^m 51 ^s .42 |
| St. Louis, west of Greenwich, | 6 0 49.11 |
| Corres. sidereal time at Greenwich, | <u>0 16 40.53</u> |
| Corr. to reduce $16^m 40^s.53$ to mean time, | — 2.73 |
| Mean time interval since sidereal noon, | <u>0 16 37.80</u> |
| Mean time of sidereal noon at Gr., | 8 20 15.29 |
| Required mean time at Greenwich, | <u>8 36 53.09</u> |
| St. Louis, west of Greenwich, | 6 0 49.11 |
| Local mean time, | <u>2 36 3.98</u> |

This method is shortened in much the same manner as the first. Having reduced the given interval to a mean time interval, we may add it directly to the Greenwich mean time of sidereal noon; but in this case, since $18^{\text{h}} + 8^{\text{h}}$ is more than 24^{h} , we must take the value for November 14, in order to reckon from the sidereal noon at Greenwich nearest our own.

The correction for longitude is introduced for the same reason as that given in the first method.

In arranging the reduction it is immaterial just where the corrections are introduced if their proper signs are employed.

| | |
|---|---|
| Local sidereal time, | 18 ^h 15 ^m 51 ^s .42 |
| Gr. mean time of sidereal noon, Nov. 14, | 8 24 11.20 |
| Corr. to reduce 18 ^h 15 ^m 51 ^s .42 to mean time, | - 2 59.53 |
| Corr. to reduce 6 ^h 0 ^m 49 ^s .11 to mean time, | - 59.11 |
| Local mean time, | 2 36 3.98 |

At first it looks as if the sum of these two corrections, $-3^{\text{m}} 58^{\text{s}}.64$, is very different from that in the longer process. There, however, a day was dropped before corrections were introduced, and here not till afterward. If the correction for this day, $-3^{\text{m}} 55^{\text{s}}.91$, is subtracted from $-3^{\text{m}} 58^{\text{s}}.64$, the remainder, $-2^{\text{s}}.73$, is the same as that above.

53. For convenience of reference, the two solutions of the problems in Sections 51 and 52 are placed side by side. \ominus stands for sidereal time, as usual; λ for longitude, and V_0 and V'_0 , respectively, for the sidereal time of mean noon and the mean time of sidereal noon.

MEAN TIME REDUCED TO SIDEREAL TIME. Poughkeepsie, Apr. 2, 1898.

| | | |
|---|---|---|
| Mean time = 20 ^h 17 ^m 55 ^s .40 | Mean time | = 20 ^h 17 ^m 55 ^s .40 |
| $V_0 = 0 47 20.99$ | V_0 | = 0 43 24.44 |
| CORR. FOR | | |
| 1 ^h 13 ^m etc. = <u> + 12.07</u> | Corr. for λ | = + 48.55 |
| $\ominus = 21 5 28.46$ | Corr. for 20 ^h 17 ^m etc. = <u> + 3 20.07</u> | = <u>21 5 28.46</u> |

SIDEREAL TIME REDUCED TO MEAN TIME. St. Louis, Nov. 15, 1898.

| | |
|--|--|
| $\odot = 18^{\text{h}} 15^{\text{m}} 51^{\text{s}}.42$ | $\odot = 18^{\text{h}} 15^{\text{m}} 51^{\text{s}}.42$ |
| $V_0 = 15 \ 38 \ 22.53$ | $V'_0 = 8 \ 24 \ 11.20$ |
| $\odot - V_0 = 2 \ 37 \ 28.89$ | Corr. for $\odot = -2 \ 59.53$ |
| Corr. for $\odot - V_0 = -25.80$ | Corr. for $\lambda = -59.11$ |
| Corr. for $\lambda = -59.11$ | Mean time = 2 36 3.98 |
| Mean time = 2 36 3.98 | |

In reducing mean time to sidereal time, or *vice versa*, it is desirable to employ both methods, and thus obtain an independent check.

54. Error of standard watch obtained from sidereal clock.—

In order to compare a standard time-piece with a sidereal clock, it is convenient to know the sidereal time of standard noon. When the sidereal time of local mean noon has been found for the standard meridian (§ 53), this time increased or decreased by the difference in longitude between the standard and local meridians gives the local sidereal time of standard noon.

EXAMPLE 1.—Find the sidereal time of standard noon at Smith College Observatory, Northampton, Mass., Nov. 7, 1896.

| | |
|---|--|
| Sidereal time at Greenwich, mean noon, | 15 ^h 8 ^m 44 ^s .30 |
| Accel. for 75th meridian, 5 ^h west of Gr., | + 49.28 |
| Sidereal time at noon at 75th meridian, | 15 9 33.58 |
| S. C. Observatory, east of 75th meridian, | 9 26.90 |
| Sidereal time at standard noon at S. C. O., | 15 19 0.48 |

As long as the standard meridian of this place remains unchanged, the correction to be applied to Greenwich noon to give the local sidereal time of standard noon is a constant quantity, 10^m 16^s.18.

EXAMPLE 2.—What is the error of a watch keeping standard time when compared at standard noon with a sidereal clock, the date and place being the same as in Example 1?

If the comparison is made to the nearest second, and if both time-pieces are correct, the clock should show 15^h 19^m 0^s (Ex. 1)

at standard noon by the watch. But on the date required, the clock was $1^m 56^s$ fast, so its face reading at standard noon should be $15^h 20^m 56^s$. If the sidereal clock shows less than this, the watch is fast by the difference between the two; if more, the watch is slow by this difference.

In making the comparison, "time" was called when the watch marked noon, and an assistant looking at the clock gave the corresponding clock time $15^h 20^m 46^s$, making the watch 10^s fast.

EXAMPLE 3. — Keeping all other conditions the same as in Example 2, find the error of the watch at $11^h 18^m$ A.M.

The sidereal-clock time corresponding to standard noon was $15^h 20^m 56^s$ (Ex. 2), and if the clock and watch kept the same kind of time, the clock time corresponding to $11^h 18^m$ would be found by subtracting 42^m from $15^h 20^m 56^s$; but the sidereal clock gains 10^s an hour on mean time (§ 48), so in 42^m or $0^h.7$ it would gain 7^s , and the required clock time corresponding to $11^h 18^m$ watch time would be $14^h 38^m 49^s$. At $17^m, 18^m,$ and 19^m by the watch, comparisons were made with the sidereal clock, and each time the number of seconds read was 38 instead of 49, so according to this comparison the watch was 11^s fast.

If any two corresponding times of the watch and clock are written down, the error of the watch may be found later, at leisure.

55. Location of bodies not on star-maps. — When the coördinates of the sun and moon, planets and comets are known, these bodies can be placed on star-maps, just as towns are located by means of their latitude and longitude on the maps of a common geography.

EXAMPLE. — Find the position of Venus, on Young's Uranography, for Aug. 12, 1896.

The right ascension and declination of Venus taken from the Ephemeris for this date are, respectively, $10^h 10^m$ and $+12^\circ 52'$.

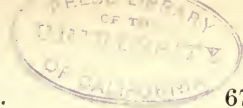

A glance at these coördinates and the Uranography shows that the planet is to be placed on Map III, near Regulus. To locate it more accurately, take a narrow strip of plotting paper, say with 10 divisions to the inch, and place it on the 10^h-circle so that its edge coincides with that circle between +10° and +20° of declination. On this strip of paper 6.3 divisions are found equal to 10° of declination on this section of the map. Therefore 1° equals 0.63 of a division; and since the planet is nearly 3° north of the 10°-parallel of declination, its coördinate on the hour-circle is 0.63×3 , or 1.9 divisions measured on the paper above the 10°-parallel of declination.

To find the corresponding coördinate in right ascension, another strip of this paper is laid across the first at right angles to it, passing through the point just determined. Here it is seen that 7.6 divisions on the paper equal an hour on the map; and as the planet is 10^m east of the 10^h-circle, it lies on the map 1.3 divisions along the second strip measured from the point of intersection between the two. In this illustration, as often happens in connection with simple mechanical operations, the description is longer than the process itself.

56. Coördinates estimated directly from maps. — The converse of the method just described is convenient in finding the right ascension and declination of a star from maps a little more accurately than by simple inspection.

EXAMPLE. — Find the right ascension and declination of α Aquilæ from Young's Uranography.

When a strip of plotting paper is passed through α Aquilæ so that its edge is parallel to the 20^h-circle, 6.4 divisions correspond to 10° of declination, and the star's centre lies 1.1 divisions below the 10°-parallel of declination. Its declination is then $10^\circ - \frac{1.1}{6.4}$ of 10°, or 8°.3. In like manner the right ascension is found by passing a strip of paper through the star so that it lies parallel to the 10°-parallel of declination. As 7.6 divisions

equal an hour here, and the star is 1.9 divisions west of the 20^h-circle, its right ascension is 20^h - $\frac{1}{7} \frac{9}{6}$ of 60^m; that is, 19^h 45^m.0. The mean place of α Aquilæ taken from the Ephemeris for 1896 is, right ascension 19^h 45^m.7 and declination + 8°.6.

57. Catalogue stars identified. — Star catalogues and maps are often in use whose epochs differ by a number of years, and in order to identify a catalogue star on a map it is sometimes necessary for the naked-eye observer to take into account the effect of precession. For this purpose it is usually accurate enough to multiply the annual precession for any year involved by the number of years between the dates of the catalogue and map. When the catalogue employed does not give annual precession in right ascension and declination, these quantities may be computed or taken directly from another catalogue.

EXAMPLE 1. — Find the annual precession in right ascension and declination for the *Bonn Durchmusterung* star + 23°, 522.

The formulæ for computing annual precession are given in every volume of the American Ephemeris, but if the number of decimal places is limited to one for arc and two for time, these formulæ do not vary for a number of years. They are, for right ascension, $3^s.07 + 1^s.34 \sin \alpha_0 \tan \delta_0$, and for declination, $20''.1 \cos \alpha_0$.

The values for α_0 and δ_0 taken from the Bonn Catalogue are 54°.4 and 23°.5, respectively, and the numerical calculation is as follows:

| | | | |
|---------------|-----------------|---------------|-----------------|
| log 1.34 | = 0.1271 | | |
| log sin 54°.4 | = 9.9101 | log 20.1 | = 1.3032 |
| log tan 23.5 | = <u>9.6383</u> | log cos 54°.4 | = <u>9.7650</u> |
| log 0.47 | = <u>9.6755</u> | log 11.7 | = <u>1.0682</u> |

The annual precession obtained is then + 3^s.54 in right ascension, and + 11^{''}.7 in declination. The values for these quantities taken directly from the Berlin Zone of the Gesellschaft Catalogue for 1875 are 3^s.55 and 11^{''}.6, respectively.

EXAMPLE 2. — Identify the *Bonn Durchmusterung* star $+23^{\circ}$, 522 on Proctor's "New Star Atlas."

The epoch of this catalogue being 1855 and that of the Atlas 1880, a correction for precession for 25 years must be applied. Taking the annual precession found in Example 1, we have:

| | | |
|--|----------------------------|-------------------|
| Approx. annual precession for <i>B. D.</i> $+23^{\circ}$, 522, | R.A. $+ 3^{\text{s}}.5$ | Decl. $+ 12''$ |
| Approx. precession for 25 years, | $+ 1^{\text{m}}.5$ | $+ 5'$ |
| Catalogue place for <i>B. D.</i> $+23^{\circ}$, 522, | $3^{\text{h}} 37 .7$ | $+ 23^{\circ} 29$ |
| Position of star on Proctor's Atlas, | $3 39 .2$ | $+ 23 34$ |

Referring to Proctor's maps, we see that the star must be one of the Pleiades, and the coördinates of Merope, or 23 Tauri, read according to Section 56, are $3^{\text{h}} 39^{\text{m}}.2$ and $+23^{\circ}.5$. The Bonn star is then 23 Tauri.

EXAMPLE 3. — Identify 1064 of Porter's Cincinnati Catalogue on the charts of the *Bonn Durchmusterung*.

In this catalogue annual precession is given directly, and the required position is found thus:

| | | |
|---------------------------------------|--------------------------------|---------------------|
| Approx. annual precession, | R.A. $+ 3^{\text{s}}.1$ | Decl. $- 20''$ |
| Approx. precession from 1890 to 1855, | $- 1^{\text{m}} 48^{\text{s}}$ | $+ 11'.7$ |
| Catalogue position, | $11^{\text{h}} 44 32$ | $- 10^{\circ} 26.1$ |
| Position for the Bonn charts, | $11 42 44$ | $- 10 14.4$ |

Since in this example we are going back in time from the catalogue to the chart, precession must be applied with opposite signs from those given in the catalogue.

The star is found on the chart as Merope was identified above.

CHAPTER IV.

CELESTIAL GLOBE AND HELIOTELLUS.

THERE are many simple problems in astronomy which may be solved directly by means of the celestial globe. The results thus obtained, though not so accurate as those derived by calculation, are entirely satisfactory for many purposes.

Doubtless a globe* made with numerical exercises definitely in view would often prove more serviceable than the common globe of commerce.

EXERCISES FOR THE CELESTIAL GLOBE.

58. Dimensions and circles.

1. Find the diameter of the globe employed.
2. Find the measure of the smallest unit on the celestial equator in arc and in time.
3. Compare the linear measures of a degree on the equator and on a parallel 40° north.
4. Name and define the different circles represented on the globe.
5. Explain the meaning of the figures on the celestial equator, ecliptic, meridian ring, and horizon plate.
6. Explain how both altitude and declination can be measured on one of the circles so that the declination of a body is a part of its altitude.
7. Show from the globe that if hour-circles are great circles passing through the north pole, they must be perpendicular to the equator.
8. Show that the altitude of the pole is equal to the declination of the zenith.
9. Given the latitude of any place, find the meridian altitude of the equator.

* The Astronomer's Globe, *Popular Astronomy*, June, 1897.

10. Read from the horizon plate for any date the amplitude or azimuth of the points at which the celestial equator intersects the horizon.

11. Show whether these points of intersection vary on different dates at the same place, or at different latitudes on the same date.

12. At noon on the days of the autumnal equinox and winter solstice, find for the place of observation the meridian altitude of the ecliptic and the points at which it intersects the horizon.

13. For the same dates, find the points at which the ecliptic crosses the meridian and the horizon in latitude $+70^\circ$, $+15^\circ$, -5° , and -50° .

59. Orientation.

1. Orient the globe to show what aspect the heavens will present to an observer at the equator.

2. Orient the globe to show the aspect of the heavens at the north pole.

3. Orient the globe for nine o'clock on a given night at the place of observation.

4. Check the position of the globe for mean noon by the sidereal time of mean noon given in the Ephemeris.

5. Check any position of the globe by the sidereal clock.

60. The sun.

1. Locate the sun by coördinates taken from the Ephemeris for March 21, for the years 1865, 1875, and 1895.

2. Find how accurately dots near the ecliptic fix the sun's position for the dates marked on the globe.

3. Measure the variation in the sun's declination during an interval of five days before the autumnal equinox.

4. Show that the sun is above the horizon longer at Charleston than at Boston on any day in the last week of December.

5. Find the time of sunrise at Moscow, Russia, May 26, 1896.*

6. Assuming that the sun's motion is uniform in the ecliptic, show that the clock and sun-dial are together four times a year.

* A newspaper correspondent present at Moscow to witness the coronation of the Czar on this date stated that the sun rose at midnight.

7. Under the same conditions, show on what four dates the difference in time between the clock and the sun-dial is a maximum.

8. Taking the sun-dial as the standard, find from the globe the signs of this correction and its approximate value.

9. Illustrate the diurnal paths of the sun as seen on August 26, at Stockholm, Sweden; Northampton, Massachusetts; and Arequipa, Peru.

10. If the inclination of the ecliptic is increased 10° , find the effect of the change upon the length of the days at a given place.

61. The moon.

1. Locate the moon by its right ascension and declination taken from the Ephemeris.

2. Mark the moon's position on the globe at intervals of about an hour from eight o'clock one night to the same hour on the following night.

3. In like manner fix the moon's path at intervals of a few days during one lunation.

4. Take the longitude of the moon's ascending node for June 19, 1885, and place a movable wire circle on the globe so as to give the approximate position of the moon's path among the stars for that month.

5. When the moon has reached the southern limit of this circle, trace its diurnal path for the horizon of Savannah, Ga.

6. When it has reached the northern limit, trace the diurnal path for the same place.

7. Repeat Exercises 4, 5, and 6, changing the date to Oct. 7, 1894.

8. Show that a change of 10° in declination has a marked effect upon the time of the moon's rising, but not on its meridian passage.

62. Planets.

1. Locate Mercury, Venus, Mars, Jupiter, and Saturn for a particular evening and find which planets can be seen at convenient hours.

2. Check an observed altitude and azimuth of a planet.

3. Show at what time of the year Mercury is favorably placed for observation at eastern elongation.

4. Verify the observed distance between a planet and a star when the two are in conjunction.

5. Read from the globe the time when Venus sets, and compare the hour and minute with that given in the almanac for the same date.

6. Trace the diurnal path of Mars or Jupiter for a given day, finding the meridian altitude and the azimuth at rising and setting.

63. Comets.

1. On Nov. 18, 1895, one of the daily papers announced that a new comet had been discovered the day before at the Lick Observatory, with right ascension $13^{\text{h}} 44^{\text{m}}$, and north declination $1^{\circ} 40'$; fix its position on the globe, and find at what hour on the day of discovery it was most favorably situated for observation at Lick Observatory.

2. Find during what part of the day, near the date of discovery, the comet was above your own horizon.

3. If an observer is approximately in the latitude and longitude of Washington, ascertain what conditions will cause one and the same comet to appear in the west in the evening and in the east on the following morning.

64. Stars.

1. Measure the altitude and azimuth of α Leonis at 8^h P.M., May 30, at Charlottesville, Va.

2. If the place of observation is Utica, N. Y., find the difference in the meridian altitudes of a given star, obtained from the Ephemeris and from the globe.

3. Show to what latitude you must journey in order to see the constellation called the Southern Cross when it is just above the horizon on the meridian.

4. Read the meridian altitude of α Crucis for Havana, Rio de Janeiro, and Honolulu.

5. Find two bright stars north of the celestial equator which are on the meridian about the same time as the vernal equinox.

6. Measure the difference in degrees between β and γ Ursæ Minoris, α and β Pegasi, and α and γ Leonis.

7. Given the right ascension of a star $3^h 1^m$ and declination $+40^\circ 33'$, find it on the globe.
8. Measure the celestial latitude of δ Capricorni.
9. Find a star that rises in the east and sets in the west point of the horizon.
10. Ascertain the date at which Regulus rises about eight o'clock in the evening at the place of observation.
11. Keeping the same date, find how much earlier or later this star rises at a place 20° farther north but in the same longitude.
12. Find how the star's time of rising on the same day is affected, if the observer is 20° farther south but in the same longitude.
13. Show how the azimuth at rising is affected by these changes in latitude on the part of the observer.
14. Repeat the four preceding exercises, taking the star Spica instead of Regulus.
15. Read the sidereal time of the rising, southing, and setting of any three bright stars for any horizon.
16. Find a bright star whose diurnal path is above the horizon less than eight hours.
17. Ascertain what portion of its diurnal path α Andromedæ traverses above the horizon at the place of observation.

65. Precession and star-places.

1. Find what change precession has made in the place of the vernal equinox since the date for which the globe was manufactured.
2. Apply the correction for precession of the equinox to the globe right ascension and declination of α Leonis, γ Ursæ Minoris, and α Aquilæ, and see whether the resulting values agree better than the direct readings with the right ascensions and declinations given in the current number of the American Ephemeris.
3. Check the accuracy of the original star-places on the globe by comparing them with the corresponding places given in a catalogue having nearly the same date as the globe.
4. See whether an earlier date than that claimed by the makers will better suit the actual star-places.

EXERCISES FOR THE HELIOTELLUS.

66. Aspects and eclipses.

1. Illustrate phases and aspects of the moon.
2. Illustrate eclipses of the sun and moon, and show why they occur so much oftener with the heliotellus than in the heavens.
3. Find what positions of Mercury and of Venus correspond to superior and inferior conjunction.
4. Find the positions of Mercury and Venus corresponding to east and west elongations.
5. Take Venus for the Earth and the Earth for Jupiter, and illustrate superior conjunction and opposition of Jupiter.
6. Keeping the names just given to the different bodies, illustrate an eclipse, transit, and occultation of a satellite of Jupiter.

67. Periods, diameters, and distances.

1. Given the sidereal period of Mercury and Venus, find the synodic period of each from the heliotellus.
2. Measure the diameters of the different bodies of the heliotellus.
3. Express these diameters in terms of the Earth's diameter as unity, and compare the values thus obtained with the real diameters of these bodies expressed in the same unit.
4. Measure the distance of each body from the centre of the sun.
5. Compare the measures made for Mercury and Venus with the real distances of these bodies from the sun.
6. Find how the Earth's distance from the sun, as shown by the heliotellus, compares with its real distance, using in each case the Earth's diameter as unity.
7. Illustrate the variation in the length of days by means of the heliotellus.

SUGGESTIONS AND ILLUSTRATIONS.

68. Globe oriented. — The celestial globe gives in miniature a representation of the whole celestial sphere, and in order to see what part of the sphere is visible at any latitude in the northern hemisphere, we bring the north pole of the globe above

the horizon plate till its altitude equals the latitude of the place.

To find what part of the sphere is above the horizon at any given time we make the sun's place at apparent noon for the day coincide with the meridian, and then derive any required position for an earlier or later hour.

On some globes the place of the true sun at noon is indicated approximately for every day by dots placed near the ecliptic. More accurate positions for a given date are obtained by taking the sun's longitude or its right ascension and declination from the Ephemeris.

In all the exercises which follow in this chapter eastern standard time is employed, if there is no statement to the contrary.

EXAMPLE 1.—Orient the globe to show the aspect of the heavens at local mean noon, Jan. 6, 1897, Northampton, Mass.

Having placed the north pole of the globe at an altitude of $42^{\circ}.3$, the latitude of Northampton (Appendix E), we bring the dot below the ecliptic, marked January 6, to the edge of the graduated side of the meridian ring. The globe now shows the aspect of the heavens at apparent noon, and the right ascension of the meridian read from the celestial equator (§ 39) is $19^{\text{h}} 10^{\text{m}}.8$. But the mean sun was on the meridian $6^{\text{m}}.4$ earlier than the true sun, as this is the equation of time (§ 36) for the given date, and the mean sun is in advance. So to find the required aspect at mean noon we turn the globe backward $6^{\text{m}}.4$, and the corresponding right ascension of the meridian ring is $19^{\text{h}} 4^{\text{m}}.4$.

A direct check for this position may be obtained from the Ephemeris, for the right ascension of the meridian at mean noon is, of course, the mean sun's right ascension at that time. This right ascension taken from the Ephemeris for Jan. 6, 1897, is $19^{\text{h}} 6^{\text{m}}.1$, a value $1^{\text{m}}.7$ larger than that read from the globe. The difference is mainly due to the difference of about half a degree between the two longitudes of the sun on

Jan. 6, 1870, the date of the globe, and 1897, the date of the exercise (§ 71). Had the latter date been 1899, there would have been no appreciable variation.

EXAMPLE 2. — Orient the globe to show the aspect of the heavens at nine o'clock in the evening of Jan. 6, 1897, making use of no auxiliary except a common almanac.

First, as in Example 1, we find the position for apparent noon by bringing the dot for January 6 to the meridian ring. As above, the corresponding right ascension of the meridian is $19^{\text{h}} 10^{\text{m}}.8$. Since standard noon for this date comes 3^{m} after apparent noon (Old Farmer's Almanac), the globe must be turned 3^{m} west, making the right ascension of the meridian which corresponds to standard noon, $19^{\text{h}} 13^{\text{m}}.8$. But the aspect required is for nine o'clock in the evening; that is, 9^{h} later than standard noon; so the globe must be turned 9^{h} farther toward the west, bringing to the meridian ring a point whose right ascension is $19^{\text{h}} 13^{\text{m}}.8 + 9^{\text{h}}$, or $4^{\text{h}} 13^{\text{m}}.8$.

The hour spaces on the celestial equator are reckoned in sidereal units, but the hourly gain of 10^{s} (§ 48) on standard time is easily taken into account if desired. Thus 9^{h} of standard time equals $9^{\text{h}} 1^{\text{m}}.5$ sidereal time (§ 48), and this angle being measured off on the celestial equator, the right ascension of the meridian is found to be $4^{\text{h}} 15^{\text{m}}.3$.

If the almanac at hand gives the equation of time instead of the difference between standard and apparent noon, the latter difference is found by combining the equation of time with the longitude from the standard meridian (§ 37). Thus, in the example given above, the meridian of Northampton is $9^{\text{m}}.4$ east of its standard meridian, and consequently standard noon comes $9^{\text{m}}.4$ after mean local noon. But apparent noon comes 6^{m} after local mean noon (Jayne's Almanac), and so standard noon comes as above, 3^{m} after apparent noon.

From the preceding discussion it follows that the globe may be turned directly to show any required aspect as soon as the

right ascension of the meridian for that instant is known. But the right ascension of the meridian equals the hour-angle of the vernal equinox or sidereal time (§ 39). Therefore, in order to orient the globe for 9^h P.M., Jan. 6, 1897, it is only necessary to reduce this time to sidereal time. Passing to the equivalent local time, 9^h 9^m.4 (§ 35), we have, according to Section 53:

| | |
|---|---|
| Local M. T. = 9 ^h 9 ^m .4 $V_0 = 19 \quad 5 \quad .3$ Corr. for 14 ^h = $\frac{2 \quad .3}{}$ $\ominus = 4 \quad 17 \quad .0$ | Local M. T. = 9 ^h 9 ^m .4 $V_0 = 19 \quad 5 \quad .3$ Corr. for λ = $ \quad 0 \quad .8$ “ “ 9 ^h 9 ^m .4 = $\frac{1 \quad .5}{}$ $\ominus = 4 \quad 17 \quad .0$ |
|---|---|

This method, of course, requires the quantity V_0 to be taken from the Ephemeris. Indeed, if results are desired within a minute, the Ephemeris must be employed, for sun fast, however defined, is only given to the nearest minute in common almanacs.

69. Orientation checked.—If either one of the two methods given in the preceding section is used in orienting the globe, the other may be employed as a check. A sidereal clock, when there is one at hand, affords an easy means of making an independent check.

EXAMPLE.—Find, by consulting a sidereal clock, the right ascension of the meridian which corresponds to 9^h P.M., at Northampton, Mass., Jan. 6, 1897.

The comparison made about 1^h P.M. on this date gave:

| | Watch. | | Sidereal clock. |
|--------------|---|------------|---------------------------------------|
| Face time | = 12 ^h 58 ^m .0, | Corres. to | 20 ^h 16 ^m .8 |
| Error | = $\frac{+ 2 \quad .0}{}$, | Error | = $\frac{- 1 \quad .1}{}$ |
| Correct time | = 1 0 .0, | Corres. to | 20 15 .7 |

Here, as usual, the sidereal time is reckoned with the period of 24^h. The plus sign before the error indicates that the time-piece is slow, the minus sign that it is fast (Young *, Art. 53).

* See Preface.

To find the sidereal time when the watch time is 8^{h} later, we must add to $20^{\text{h}} 15^{\text{m}}.7$, 8^{h} increased by $1^{\text{m}}.3$, the acceleration for this interval. Therefore $4^{\text{h}} 17^{\text{m}}.0$ is the right ascension of the meridian at $9^{\text{h}} 0^{\text{m}}.0$ P.M., a result which agrees with that found by the second method of orienting.

70. Zenith point fixed. — Whenever measures are to be made with reference to a particular horizon, it is convenient to have the zenith point fixed on the globe. For any position this point is found in the plane of the meridian, and at that graduation above the equator which equals the latitude of the observer. Its place may be marked on a bit of paper moistened and pressed upon the globe.

71. Location of the sun and other heavenly bodies. — The bright stars and a number of reference circles are usually marked on a celestial globe, but the places of the sun, moon, and planets are found at any required time by means of their coördinates taken from the Ephemeris, and in like manner comets can be located from positions given in current astronomical publications.

EXAMPLE 1. — From the sun's longitude find its position at apparent noon at Northampton, Mass., Jan. 6, 1897.

The sun's longitude at the Greenwich meridian for this date is $286^{\circ}.5$, and since the hourly difference is $153''$, the longitude at apparent noon at Northampton is $0^{\circ}.2$ greater, or $286^{\circ}.7$ (§ 44). Taking a point on the ecliptic with this longitude as the sun's place, we see that it is $0^{\circ}.7$ in advance of the dot for the sun on the day which has the longitude $286^{\circ}.0$.

EXAMPLE 2. — At Northampton, Mass., given the sun's right ascension $19^{\text{h}} 12^{\text{m}}.5$, and its declination $-22^{\circ}.4$, at apparent noon, Jan. 6, 1897, find its place on the celestial globe.

The point on the celestial equator corresponding to the right ascension given was brought to the graduated side of the meridian ring. From the zero on the ring, declination was then measured downward, and hence the point opposite the gradua-

tion $22^{\circ}.4$ fixed the place of the sun. The mean of three readings gave its longitude, $286^{\circ}.5$, a value which agrees closely with that obtained from the Ephemeris in Example 1.

72. Distance between celestial objects.—Since the shortest distance between any two points on the surface of a sphere is measured on the arc of a great circle joining them, distances between objects on the globe may be determined by passing a narrow strip of paper through their centres. The number of degrees corresponding to the intervening space is then read off by laying the paper on one of the graduated circles of the globe.

EXAMPLE 1.—Find the number of degrees between the stars γ and θ Aquilæ.

Having located these stars on the globe by their mean places for 1897 (§ 71), we measure the distance between them as just described. The value found, $13^{\circ}.0$, does not vary $0^{\circ}.1$ from that obtained directly from the globe stars γ and θ Aquilæ, though neither one agrees with its catalogue place for the year.

EXAMPLE 2.—According to the New England Almanac, a conjunction of the moon and Venus occurred Jan. 6, 1897; find the distance separating these two bodies at 7^h P.M., Northampton, Mass.

Instead of using mean places for the year, as in the case of stars, it is necessary to obtain the coördinates of the moon and planet from the Ephemeris for the given hour. By interpolating between January 6 and 7 (§ 44), the right ascension found for Venus is $22^{\text{h}} 10^{\text{m}} 36^{\text{s}}$, and the declination $-12^{\circ} 53'.7$.

For the moon we turn to p. VI for the month, and take out the values $22^{\text{h}} 18^{\text{m}} 44^{\text{s}}$ and $-8^{\circ} 47'.2$, which are opposite 12^{h} , the Greenwich time corresponding to the given hour at Northampton. The distance measured on the globe between the two points plotted from these coördinates is $4^{\circ}.6$.

When the right ascensions and declinations of heavenly bodies are known, an independent check of the distance between them may be derived by trigonometry.

EXAMPLE 3.—Find by calculation the number of degrees between the moon and Venus at 7^h P.M., Jan. 6, 1897, Northampton, Mass.

In Fig. 9, let P' be the south pole of the celestial sphere, and V and M the places of Venus and the moon. Then in the oblique spherical triangle $P'MV$, two sides and the included angle are known; for the sides $P'V$ and $P'M$ are the complements of the declinations of Venus and the moon, and the angle at P' is the difference between the right ascensions of these two bodies.

The trigonometrical formulæ* to be employed are:

$$\begin{aligned} \tan m &= \cos C \tan a \\ \cos c &= \cos a \sec m \cos (b - m) \end{aligned}$$

where m is an auxiliary angle, C the known angle between the known sides a and b , and c the unknown side required. We see, then, that in the given example we have the following relations:

$$\begin{aligned} \angle \text{ at } P' &= C = 8^m 8^s = 2^\circ 2'.0 \\ P'V = a &= 77^\circ 6'.3 \\ P'M = b &= 81 12.8 \end{aligned}$$



FIG. 9.

The solution may be arranged as follows:

| | | | |
|--------------------------------|-------------------------|-----------------------|-------------------------|
| $\log \cos P'(2^\circ 2'.0)$ | $= 9.99973$ | $\log \cos P'V$ | $= 9.34863$ |
| $\log \tan P'V(77^\circ 6'.3)$ | $= \underline{0.64028}$ | $\log \sec m$ | $= 0.65110$ |
| $\log \tan m$ | $= 0.64001$ | $\log \cos (P'M - m)$ | $= \underline{9.99888}$ |
| auxiliary m | $= 77^\circ 5'.8$ | $\log \cos VM$ | $= 9.99861$ |
| $P'M - m$ | $= 4 7.0$ | $VM = 4^\circ 35'$ | |

* "Wentworth's Trigonometry," § 56.

Neither method for finding distances includes refraction or parallax, but since their effects in such examples are differential, they may be neglected altogether.

73. Place of δ Capricorni verified. — In order to test the position of δ Capricorni, we may compare the coördinates obtained from the globe with those given in one of the current astronomical year books.

After the star's place has been made to coincide with the meridian ring, its right ascension is the right ascension of the meridian read from the celestial equator, and its declination is the distance between the equator and the star's place read on the meridian ring. The mean results compared with the catalogue place are as follows :

COÖRDINATES OF δ CAPRICORNI.

| | From the globe. | From the Berliner Jahrbuch, 1897. |
|------------------|------------------------------------|--------------------------------------|
| Right ascension, | 21 ^h 39 ^m .0 | 21 ^h 41 ^m .4 |
| Declination, | — 17°.6 | — 16°.6 |

If corrections for precession for 27 years (§ 57) are applied, the error in right ascension is diminished by about 1^m.5, but that in declination by less than 0°.2.

It is possible that the remaining errors in the globe place may be due to the meridian ring. If, for instance, that does not lie exactly in the plane of the circle passed through the zenith and the poles, it ought not to be employed in finding coördinates. Though the location of the sun gives no indication of such an error, let us place the star independently of the ring.

To obtain its right ascension we measure the distance on its parallel of declination to the nearest hour-circle, and compute the corresponding value on the equator. The distance between the point fixed on the equator and the marked place of the star is the required declination.

Thus, laying a strip of rectangular paper between δ Capricorni and the circle for 22 hours, we find the space to be 8.8 divisions, and this multiplied by the secant of $-17^\circ.5$ (§ 20, d) equals 9.2. Since the star lies between the circles for 21 and 22 hours, we measure the distance corresponding to 9.2 divisions backward on the equator, and obtain the right ascension $21^h 38^m.8$. The declination derived is $-17^\circ.4$, and the close agreement of both coördinates with those read at first leads us to conclude that the errors found are due to the globe employed and not to the method of testing the place of δ Capricorni.

74. Azimuth and altitude. — The azimuth of a heavenly body is most readily measured when it is on the horizon, for then the only adjustment required is for latitude. After this has been made, the mark locating the body is brought to the eastern or western horizon, and its angular distance from the nearest cardinal point combined with the azimuth of that point gives the azimuth required.

EXAMPLE 1. — What is the azimuth of Regulus when the star is rising at Charlottesville, Va.?

Facing north, I turned the north pole of the globe toward the north pole of the heavens, making its altitude equal to $38^\circ.0$, the latitude of Charlottesville, and then brought the corrected place of the star into the plane of the horizon plate on the right hand. While the globe was held firmly in this position, by crowding something soft between its surface and the plate, the distance of the corrected star-place from the north point was determined by passing a narrow strip of paper between the two, so that its edge was in the plane of the horizon plate. This distance, $73^\circ.8$, added to 180° , the azimuth of the north point, gives $253^\circ.8$ as the azimuth of the star at rising. If the uncorrected star-place is taken, this value is diminished by $0^\circ.1$.

Since, however, celestial objects are seldom observed when actually on the horizon, the method employed in measuring altitude is also most accurate for azimuth. That is, the globe should be oriented, not only for latitude, but also for the time of the observation.

EXAMPLE 2. — Find the altitude and azimuth of Mercury at Northampton, Mass., Jan. 6, 1897, at 5^h 19^m P.M.

We locate the sun by its longitude, the planet by its right ascension and declination (§ 71), orient the globe for the given time (§ 68), and mark the zenith point (§ 70). Through this point and that fixed for Mercury we pass a narrow strip of paper representing a vertical circle, and extend it to the horizon plate. The angular distance intercepted on the paper between the planet and the plate is the altitude of Mercury; and its azimuth is the angle on the horizon between the south point and the foot of the circle used. It is read directly or measured, as in Example 1, according to the globe employed. The mean of several measures, from two independent orientations of the globe, made the required altitude 6°.6 and the azimuth 55°.6.

75. Numerical checks for azimuth and altitude. — It is not a difficult matter to check by calculation the coördinates measured on the celestial globe. Only declination and latitude are involved in finding amplitude, whence azimuth is immediately derived, as by definition amplitude is angular distance measured on the horizon, from the east or the west point, according to which is nearer.

The value for azimuth thus obtained is, however, only approximate, as this method takes no account of the effect of refraction on zenith distance. In order to include this correction we may employ an expression analogous to (6) in Section 40; but the more general formula, which includes both azimuth and zenith distance, is usually more convenient (Chauvenet's "Astronomy," Vol. I, Art. 14).

The three formulæ in the order mentioned are:

$$\sin a = \sec \phi \sin \delta \tag{7}$$

$$\cos \frac{1}{2} A = \sqrt{\frac{\cos \frac{1}{2} [\zeta + (\phi + \delta)] \sin \frac{1}{2} [\zeta + (\phi - \delta)]}{\sin \zeta \cos \phi}} \tag{8}$$

$$\left. \begin{aligned} m \sin M &= \sin \delta & \tan A &= \frac{\tan t \cos M}{\sin(\phi - M)} \\ \tan M &= \frac{\tan \delta}{\cos t} & \tan \zeta &= \frac{\tan(\phi - M)}{\cos A} \end{aligned} \right\} \tag{9}$$

where

| | |
|----------------------------------|---------------------------|
| ϕ = latitude of place | A = azimuth |
| δ = declination of object | ζ = zenith distance |
| a = amplitude | t = hour-angle |

The following considerations fix the quadrants of M , A , and ζ in (9). The auxiliary M is taken in the quadrant determined by the algebraic signs of $\tan M$ and $\sin M$, m being a positive number. If the tangent of A is positive, A lies in the first or third quadrant; if the tangent is negative, A is in the second or fourth quadrant, and in each case the value of t decides between the two; for an hour-angle and the corresponding azimuth must lie on the same side of the meridian. As ζ does not exceed 180° , it is determined by the sign of its tangent.

A special case arises when the altitude is measured on the meridian. As the hour-angle and azimuth are then both zero, the second and fourth equations in (9) become

$$\tan M = \tan \delta, \text{ and } \tan \zeta = \tan(\phi - M),$$

whence we derive $\zeta = \phi - \delta$. Subtracting each member from 90° , we have the relation,

$$\text{altitude, or } h, = \text{co-lat.} + \delta,$$

which is employed in finding meridian altitude directly (§ 32).

The formulæ given above enable us to obtain theoretical values for the angles measured in the preceding section.

EXAMPLE 1.—Compute in two ways the azimuth of Regulus when the star is rising at Charlottesville, Va.

Knowing the latitude of Charlottesville, $38^{\circ}.0$, and the declination of α Leonis, $+12^{\circ}.5$, we have, according to (7):

$$\begin{aligned}\log \sin \delta &= 9.3353 \\ \log \sec \phi &= \underline{0.1035} \\ \log \sin a &= 9.4388 \\ a &= 15^{\circ}.9\end{aligned}$$

Since the star has north declination, it rises north of the east point, and as azimuth is reckoned from the south point through the west and north points, we have the azimuth equal to $270^{\circ} - 15^{\circ}.9$, or $254^{\circ}.1$.

In order to apply (8) we must know the zenith distance of α Leonis; but that is evidently 90° increased by $36'.5$, the refraction on the horizon (§ 40). Carrying latitude and declination also to tenths of minutes we have:

$$\begin{array}{r r r r r} \phi = +38^{\circ} & 2'.0 & \log \cos \frac{1}{2} \text{ sum} & = & 9.52228 \\ \delta = +12 & 28.2 & \log \sin \frac{1}{2} \text{ diff.} & = & 9.92883 \\ \phi + \delta = & \underline{50} & 30.2 & \log \operatorname{cosec} \zeta & = & 0.00002 \\ \phi - \delta = & 25 & 33.8 & \log \sec \phi & = & \underline{0.10367} \\ \zeta = & 90 & 36.5 & & & \underline{19.55480} \\ \frac{1}{2}[\zeta + (\phi + \delta)] = & 70 & 33.4 & \cos \frac{1}{2} A & = & \underline{9.77740} \\ \frac{1}{2}[\zeta + (\phi - \delta)] = & 58 & 5.2 & \frac{1}{2} A & = & -53^{\circ} 12'.2 \\ A = & 253 & 36 & & & \end{array}$$

EXAMPLE 2.—Find by calculation the altitude and azimuth of Mercury at Northampton, Mass., Jan. 6, 1897, at $5^{\text{h}} 19^{\text{m}}$ P.M.

The formula to be employed is that numbered (9), and the first step is to find the hour-angle t . Now the hour-angle of a heavenly body at any instant is the sidereal time at that instant minus its right ascension (§ 39).

The time of observation given is $5^{\text{h}} 19^{\text{m}}$ P.M., the corresponding mean local astronomical time is $5^{\text{h}} 28^{\text{m}}.4$, whence is derived sidereal time $0^{\text{h}} 35^{\text{m}}.4$ (§ 53).

From the Ephemeris we find Mercury's right ascension to be $20^{\text{h}} 34^{\text{m}}.7$, giving an hour-angle $4^{\text{h}} 0^{\text{m}}.7$, or $60^{\circ}.2$. The planet's declination at the same time is $-19^{\circ}.5$. Having, then, all the quantities required, we may arrange the computation as follows :

$$\begin{array}{rcl}
 & \log \tan \delta = \overset{n}{9.5491} & \\
 \phi = 42^{\circ}.3 & \log \cos t = \underline{9.6963} & \log \tan t = 0.2421 \\
 M = \underline{-35.5} & \log \tan M = \overset{n}{9.8528} & \log \cos M = 9.9107 \\
 \phi - M = 77.8 & \log \tan (\phi - M) = \underline{0.6651} & \log \operatorname{cosec} (\phi - M) = \underline{0.0099} \\
 A = 55.5 & \log \cos A = \underline{9.7531} & \log \tan A = \underline{0.1627} \\
 \zeta = 83.0 & \log \tan \zeta = \underline{0.9120} & \\
 \text{Alt.} = 7.0 & &
 \end{array}$$

It is seen by referring to Section 74 that the altitude obtained by calculation is $0^{\circ}.4$ larger than that read from the globe, and the azimuth is smaller by $0^{\circ}.1$.

76. Graduations for a sun-dial. — The celestial globe may be taken to represent a horizontal sun-dial, its axis serving as the style, and the horizon plate as the outer rim of the dial face. The intersections of the meridian ring with this plate fix the noon line, and any other graduation can be determined by reading from the plate the number of degrees between the north point and the foot of the hour-circle corresponding to the given time.

EXAMPLE. — In latitude $+42^{\circ}.3$ at what angular distance from the noon line should we place the graduation for $9^{\text{h}} 15^{\text{m}}$ A.M.?

As circles for whole hours only are marked on the celestial globe employed, the position of the required circle was found thus. Two pieces of paper were placed about 20° apart in declination between the second and third hour-circles lying to the west of the north point. A quarter of an hour from the latter circle, measured on parallels of declination, dots were fixed on each bit of paper, and the hour-circle for $9^{\text{h}} 15^{\text{m}}$ was then represented by a narrow strip of paper passed through

them. Since this hour-circle was found to intersect the plate of the horizon $30^{\circ}.7$ from the north point, the required graduation on the sun-dial should be placed $30^{\circ}.7$ west of the north end of the noon line (§ 17).

77. Partial equation of time. — The equation of time (§ 36) may be divided theoretically into two parts, one arising from the irregular motion of the true sun, and the other due to the fact that the true sun moves on the ecliptic, while the mean or fictitious sun moves on the equator.

The signs and approximate size of the latter component may be obtained from the celestial globe (Young, Art. 203, E. Art. 498).

Beginning with the two suns at the vernal equinox, let us follow their course through 360° . Assuming that they move at uniform rates, their relative positions at any time are indicated by the same number of degrees from the equinox. Turning the globe slowly to represent diurnal motion, and taking the mean sun as the standard, we see that the true sun comes earlier and earlier to the meridian with increasing longitudes, till at 45° a maximum is reached. From that point the interval between the transits of the two suns decreases up to 90° , where they cross the meridian at the same time.

When the longitude of the true sun is 135° , there is another maximum, but here the true sun is slow as it crosses the meridian later than the other. In like manner, between the autumnal and vernal equinoxes we find two maxima, the true sun being fast at longitude 225° and slow at 315° .

The number of minutes in this maximum value for sun fast or sun slow may be read from the globe. Thus, if the point on the ecliptic with a longitude of 45° is brought to the meridian, it is found to be 10^m in advance of the 3^h -circle. According to theory the maxima should all be numerically equal, but with the globe used they vary, giving, however, a mean of $10^m.4$.

78. Sun's diurnal path in different seasons. — When it is possible the diurnal path of the sun and of other heavenly bodies should be found directly from observation, and the globe employed only to check results (§ 111), or illustrate paths described at a distance from the observer.

A few dates properly chosen ought to show the large variations which occur in the sun's diurnal path during a year at any given place.

EXAMPLE. — Locate the sun's diurnal path at Cleveland, Ohio, on the days of the equinoxes and the solstices.

We may take the equinoxes and solstices of the celestial globe as the positions of the sun on the required dates; for although these points may not be exactly right for any year, and certainly cannot be for a number of different years, their precise position and change belong to mathematical calculation rather than to illustrations made with the globe.

Having placed the north pole at an altitude of $41^{\circ}.5$, the latitude of Cleveland, let us turn the globe slowly so that the point marking the vernal equinox passes from the eastern to the western horizon. Its course indicates the sun's path for the day.

The points which it is most important to fix by measurement are the amplitude (§ 75) at rising and at setting and the altitude on the meridian. These angles for the four dates are given in the following table, which also includes the declinations of the sun when at the equinoxes and the solstices. The declinations on any particular meridian will agree closely with these values, though they may vary a tenth of a degree in either direction from place to place or from year to year.

The intercepts on the horizon in the final column are obtained by reckoning westward through the south point. Thus, since the amplitudes $32^{\circ}.4$ and $32^{\circ}.6$ lie south of the east and west points, respectively, we obtain the last angle, $115^{\circ}.0$, by subtracting their sum, $65^{\circ}.0$, from $180^{\circ}.0$.

TABLE I.—DIURNAL PATH OF THE SUN AT CLEVELAND, OHIO.

| DATE. | DECLINATION. | AMPLITUDE AT RISING. | ALTITUDE ON MERIDIAN. | AMPLITUDE AT SETTING. | INTERCEPT ON HORIZON. |
|------------------|--------------|----------------------|-----------------------|-----------------------|-----------------------|
| Vernal Equinox | 0° 0 | E. 0° 2 N. | 48° 5 | W. 0° 2 N. | 180° 4 |
| Summer Solstice | + 23 .5 | E. 32 .1 N. | 71 .9 | W. 32 .2 N. | 244 .3 |
| Autumnal Equinox | 0 .0 | E. 0 .2 N. | 48 .5 | W. 0 .2 N. | 180 .4 |
| Winter Solstice | - 23 .5 | E. 32 .4 S. | 24 .6 | W. 32 .6 S. | 115 .0 |

For the dates included, the intercepts are largest when the sun's declination is largest, and smallest when that is smallest. The meridian altitudes also increase and decrease with the declination.

79. Sun's diurnal path in different latitudes. — In order to see what effect changes in latitude have upon the sun's diurnal path, we form a table similar to that given above; but instead of taking different days at the same place, we follow the course of the sun for the same day at different places.

TABLE II.—SUN'S DIURNAL PATH AT THE SUMMER SOLSTICE.

| PLACE. | LATITUDE. | AMPLITUDE AT RISING. | ALTITUDE ON MERIDIAN. | AMPLITUDE AT SETTING. | INTERCEPT ON HORIZON. |
|---------------|-----------|----------------------|-----------------------|-----------------------|-----------------------|
| Arctic Circle | + 66° 5 | No rising. | 46° 9 | No setting. | 360° |
| Stockholm | + 59 .3 | E. 51° 4 N. | 53 .8 | W. 51° 6 N. | 283 .0 |
| Key West | + 24 .6 | E. 26 .2 N. | 88 .9 | W. 26 .0 N. | 232 .2 |
| Quito | - 0 .2 | E. 23 .4 N. | 66 .4 | W. 23 .4 N. | 133 .2 |
| Arequipa | - 16 .4 | E. 24 .5 N. | 50 .3 | W. 24 .5 N. | 131 .0 |

In this table the altitudes at Quito and Arequipa are measured on the arc of the meridian between the zenith and north point of the horizon, and the intercepts are taken so as to pass through the north point. Comparing the five paths we see that for the given date, meridian altitudes increase as places approach

the tropic of Cancer on either side, but intercepts on the horizon increase continuously northward till at the Arctic Circle there are no points of rising and setting. Indeed, owing to the effect of refraction the "midnight sun" is visible on the day of the summer solstice south of the Arctic Circle (Young, Art. 191, E. Art. 130).

Refraction is not included either here or in Table I. Its effect, if desired, should be found by mathematical formula (§ 75).

The theoretical requirement that amplitudes at rising and at setting should be numerically equal is met in only half the values given in the preceding tables, but no deviation exceeds 0.2 of a degree.

80. Varying length of days. — It is clearly seen from Tables I and II that the sun is longer above the horizon on the same calendar day in some latitudes than in others. To determine these intervals approximately, hour-angles may be read from the celestial globe.

EXAMPLE. — What is the hour-angle of the sun when setting at Stockholm on the day of the summer solstice?

If the point which marks the summer solstice is brought into the plane of the horizon plate, the sun's place thus determined lies $9^{\text{h}} 7^{\text{m}}.5$ west of the meridian ring as read from the celestial equator. This, then, is the hour-angle required at sunset.

As the globe employed gives slightly different numerical values for east and west hour-angles (§ 79), the length of the day at Stockholm and other places in Table III is found by taking the arithmetical sum of the hour-angles at sunrise and at sunset. For Stockholm, a day of $18^{\text{h}} 16^{\text{m}}$ is thus obtained.

The length determined from Loomis's Table of Semi-diurnal Arcs (§ 108) is $18^{\text{h}} 18^{\text{m}}$, giving a difference of 2^{m} . If all the days in the following table are checked in like manner, the differences vary from 0^{m} to 4^{m} .

TABLE III. — VARYING LENGTH OF DAYS.

| AT CLEVELAND. | | | AT DATE OF SUMMER SOLSTICE. | | |
|------------------|-------------|--------------------------------|-----------------------------|-----------|--------------------|
| DATE. | SUN'S DECL. | LENGTH OF DAY. | PLACE. | LATITUDE. | LENGTH OF DAY. |
| Vernal Equinox | 0°.0 | 12 ^h 4 ^m | Arctic Circle | + 66°.5 | 24 ^h |
| Summer Solstice | + 23 .5 | 15 2 | Stockholm | + 59 .3 | 18 16 ^m |
| Autumnal Equinox | 0 .0 | 12 4 | Key West | + 24 .6 | 13 34 |
| Winter Solstice | - 23 .5 | 9 0 | Quito | - 0 .2 | 12 2 |
| | | | Arequipa | - 16 .4 | 11 4 |

While the data are too limited to warrant general conclusions, we see that at Cleveland the days increase in length as the sun's declination increases, and on the day of the summer solstice days grow longer as latitudes increase.

81. Moon's path on the celestial sphere. — Before considering diurnal paths of the moon, let us locate the orbit itself.

The trace of the orbit on the celestial sphere is practically a great circle (Young, Art. 233, E. Art. 142) inclined to the ecliptic at an angle of $5^{\circ} 8'$; but the position of its nodes, that is, the points in which this circle meets the ecliptic, is constantly changing. This change is so rapid that in nineteen years the ascending node passes through the entire circle of the ecliptic.

Let us first follow the course of the path when the ascending node is at the vernal equinox.

EXAMPLE. — What was the position of the moon's orbit in October, 1894?

Turning to the Ephemeris for the year, we see that the mean longitude of the moon's ascending node was nearly zero degrees in October. It follows, therefore, that during the month this node was practically at the vernal equinox, and the descending node at the autumnal equinox.

With these two points fixed it is easy to place a wire circle

on the celestial globe so as to represent the required path. It should go northward through the vernal equinox, that is, toward the north pole of the globe; and its angular distance from the ecliptic may be found by laying off $5^{\circ}.1$ on the solstitial colure, either upward from the summer solstice or downward from the winter solstice.

This position gives to the moon's path its "farthest north," as its highest point has reached the maximum angle $5^{\circ}.1$ north of the highest point of the ecliptic, both measured on the same hour-circle. Since, in like manner, the opposite point in the path considered is $5^{\circ}.1$ south of the lowest point of the ecliptic, we conclude that both the highest and lowest points of the moon's path traced on the celestial sphere are found in one and the same position of the orbit.

If the wire circle is shifted so that the ascending node moves backward from the vernal equinox, the upper intersection of the moon's path with the solstitial colure moves southward. The extreme position in this direction is reached when the angle $5^{\circ}.1$ is measured from the summer solstice southward on the solstitial colure. The ascending node has then described half the circle of the ecliptic and is found at the autumnal equinox.

82. "High" and "low" moons. — We see from the preceding section that the moon will run highest when the ascending node of its path lies at the vernal equinox, and the moon itself has reached the highest point in its path. It will run lowest with the same position for the orbit and the moon at the lowest point.

These contrasts in diurnal paths grow less marked as the ascending node moves backward toward the autumnal equinox; and when that point is reached, the maximum altitude possible for the moon is 10° less than when the ascending node was at the vernal equinox.

Thus in nineteen years we should find two lunar months

separated by half the period, the one characterized by the greatest contrast in the moon's altitude, the other by the least contrast.

Reference to the Ephemeris shows that the four typical paths in the last nineteen-year period were described on June 12 and 26 in 1885, and on October 5 and 19, 1894. Since the moon's declination changed little more than half a degree on any of these days, small error is involved in tracing the lunar paths just as those for the sun have been traced in preceding sections.

EXAMPLE. — If the place of the moon for Oct. 19, 1894, is taken at the time of its maximum declination on that date, what is the moon's meridian altitude and its azimuth at rising and setting at Northampton, Mass.?

The maximum declination found from the Ephemeris is $28^{\circ}.7$, and the corresponding right ascension $6^{\text{h}} 0^{\text{m}}.5$. With these coördinates the place of the moon is fixed on the celestial globe, and the required angles read from the meridian ring and horizon plate are :

Azimuth at rising, $229^{\circ}.4$
 Meridian altitude, 76.4
 Azimuth at setting, 130.4

In like manner were found the other values which are given in the following table.

TABLE IV. — HIGH AND LOW PATHS OF THE MOON, NORTHAMPTON, MASS.

| DATE. | PLACE. | | AZIMUTH AT RISING. | MERIDIAN ALTITUDE. | AZIMUTH AT SETTING. |
|---------|--------------------------------|------------------|-----------------------|-----------------------|------------------------|
| | R.A. | DECL. | | | |
| 1885 | | | | | |
| June 12 | $5^{\text{h}} 59^{\text{m}}.4$ | $+ 18^{\circ}.4$ | $244^{\circ}.6$ | $66^{\circ}.0$ | $115^{\circ}.4$ |
| June 26 | $18 \ 1 \ .2$ | $- 18 \ .5$ | $295 \ .5$ | $29 \ .0$ | $64 \ .0$ |
| 1894 | | | | | |
| Oct. 5 | $18 \ 0 \ .0$ | $- 28 \ .7$ | $310 \ .8$ | $19 \ .0$ | $48 \ .6$ |
| Oct. 19 | $6 \ 0 \ .5$ | $+ 28 \ .7$ | $229 \ .4$ | $76 \ .4$ | $130 \ .4$ |

83. Paths of the full moon in summer and winter. — It is only when the moon is full, or nearly full, that its diurnal path attracts attention; for at other times a large part of its course above the horizon is traversed in the daytime. Thus it happens that high and low moons coming every month are little noticed, but almost every one has observed the full moon running high in winter and low in summer. The contrast in these paths is readily understood if we remember that the path of the moon is always near the ecliptic, and that the moon when full is distant 180° in longitude from the sun.

It follows, therefore, that when the sun is moving in summer in that part of the ecliptic which is highest above the horizon, the full moon is to be found nearly opposite, close to the ecliptic, where that circle lies nearest the horizon. In winter, of course, the places of these bodies are interchanged.

EXAMPLE. — On July 25, 1896, at Northampton, Mass., what was the difference in the amplitude of the sun and moon when rising, and what their difference in altitude at meridian transit?

Having obtained the times of rising and southing from the Old Farmer's Almanac, we take out the corresponding coördinates from the Ephemeris and locate the bodies on the celestial globe. The required differences read directly show that the sun rose 48° farther north than the moon and crossed the meridian 34° nearer the zenith.

An illustration of the two paths determined by observation on July 25 and 26 is given in Fig. 15, Section 138.

84. Diurnal path of Encke's comet. — The place of a comet can be found on the celestial globe at any time for which its right ascension and declination are given in current astronomical publications. After this place has been marked on the globe, the diurnal path is traced as usual.

On Dec. 22, 1894, at 8^h 34^m P.M., mean local time, the coördinates * for Encke's comet obtained at Smith College Observatory were:

Right ascension, 22^h 16^m.2
 Declination, + 4°.2

By comparing these values with those found two days later, it is seen that in 24 hours right ascension changed less than a minute of time, and declination only a few minutes of arc. No appreciable error, therefore, is involved in assuming that the comet occupied the given place on the sphere throughout the day, December 22. The principal data for the diurnal path read from the globe are:

| | | |
|--------------------|--------------------------------|----------------------------------|
| | At rising. | At setting. |
| Azimuth, | 263°.8 | 95°.9 |
| Hour-angle, — | 6 ^h 18 ^m | + 6 ^h 16 ^m |
| Meridian altitude, | 51°.8 | |

The arithmetical sum of these two hour-angles, 12^h 34^m, gives the interval during which the comet was above the horizon. But half its course was traversed in broad daylight, as is evident from the times when the comet rose and the sun set.

In order to find the time of the comet's rising we add the hour-angle to the right ascension (§ 39), and from the sidereal time obtained deduce the local mean time, 9^h 55^m A.M. But 4^h 30^m was the local time of sunset on the given date, so that during 6^h 35^m the sun and comet were above the horizon together.

85. Rising and setting of stars. — The star-places marked on any globe are doubtless affected by errors, first in fixing the original positions, and second by the changes in right ascension and declination caused by precession of the equinoxes (§ 73). It is safe, however, to neglect these errors when differential results are desired, as in the first two examples which follow.

* The *Astronomical Journal*, Vol. XV, p. 103.

EXAMPLE 1. — What is the difference in the time and place of the rising of Aldebaran at Galveston, Tex., and at a place in the same longitude, but 15° farther north in latitude?

The star-place marked on the globe having been brought to the horizon plate, the angles read are:

| | | |
|-------------|---------------------|---------------------|
| | $\phi = 29^\circ.3$ | $\phi = 44^\circ.3$ |
| Azimuth, | $251^\circ.6$ | $247^\circ.4$ |
| Hour-angle, | $-6^h 40^m$ | $-7^h 7^m$ |

Since the right ascension is constant (§ 42), the times of rising differ by the difference in the hour-angles, and Aldebaran rises 27^m earlier at the northern station than at Galveston. The point of rising at the northern station is also $4^\circ.2$ farther north.

EXAMPLE 2. — What is the difference in the time and place of the setting of the Pleiades at Fargo, North Dakota, and at a place in the same longitude but 15° farther south in latitude?

If Aleyone, the brightest star in the cluster, is taken as the particular point, we find, as above:

| | | |
|-------------|---------------------|---------------------|
| | $\phi = 46^\circ.9$ | $\phi = 31^\circ.9$ |
| Azimuth, | $125^\circ.4$ | $117^\circ.8$ |
| Hour-angle, | $7^h 50^m$ | $7^h 1^m$ |

Thus, at Fargo, Aleyone sets 49^m later and $7^\circ.6$ farther north than at the southern station.

EXAMPLE 3. — In 1899, at what day in what month does Arcturus rise at 8^h P.M., local time at Salt Lake City?

The essential part of the problem consists in ascertaining the right ascension of the meridian at apparent noon preceding the required evening, for then its date can be read directly from the globe (§ 68).

Let us begin by bringing the star's place, fixed for 1899, to the horizon plate on the right hand, as one faces north. The corresponding right ascension of the meridian is found to be $6^h 58^m.4$. But as east and west hour-angles read from this

globe differ a little, a more accurate right ascension of the meridian is obtained by taking the mean value, $6^{\text{h}} 58^{\text{m}}.2$, derived from the two hour-angles.

Now if the right ascension of the meridian was $6^{\text{h}} 58^{\text{m}}.2$ at 8^{h} P.M., mean time, the right ascension for the preceding mean noon was $6^{\text{h}} 58^{\text{m}}.2 - 8^{\text{h}} 1^{\text{m}}.3$, or $22^{\text{h}} 56^{\text{m}}.9$. When this reading on the celestial equator is brought to the meridian ring, the date below on the ecliptic close to the edge of the ring is March 3. This would be the date sought if mean and apparent noons agreed, that is, if the equation of time were zero. Its value, however, is found to be 12^{m} on March 3, and since apparent noon comes later than mean noon, the right ascension of the meridian required at apparent noon is very nearly equal to $22^{\text{h}} 56^{\text{m}}.9 + 12^{\text{m}}$, or $23^{\text{h}} 8^{\text{m}}.9$.

With this position of the meridian the corresponding date on the ecliptic is March 6. The equation of time for March 6 is $11^{\text{m}}.4$, but a difference of $0^{\text{m}}.6$ in the value taken above does not change the day of the month read from the ecliptic. Therefore we conclude that it is on March 6 that Arcturus rises at 8^{h} P.M., mean local time at Salt Lake City.

Taking the converse of the problem for a check, we compute (§ 40 (3)) the time of rising for the given date and find that it is $8^{\text{h}} 0^{\text{m}}.6$ P.M. Neither by the globe nor the check has refraction been taken into account, and since its effect is to hasten the rising of the star by nearly 4^{m} , the purely theoretical time of rising would come more nearly at eight o'clock on the evening of March 5, but unless the observer has a remarkably good horizon the globe value will doubtless agree the more closely with the actual rising of the star.

86. Synodic period of Venus from the heliotellus. — The small globes of the heliotellus representing the planets are made to revolve about the "sun" by turning a crank, and a sidereal period is marked off when a planet has passed through 360° , as

indicated by the graduated circle at the back. Therefore, in order to find the synodic period, it is only necessary to ascertain the number of revolutions required to bring the given body back again to its initial aspect.

For example, beginning with Venus at inferior conjunction, we find that it must be turned through 2.58 sidereal revolutions before the planet returns to inferior conjunction. The sidereal period of Venus is 224.7 days (Young, Art. 489, E. Art. 285), so 580 days is the required synodic period obtained with the heliotellus.

In using an instrument like the heliotellus it is well to keep the same direction of motion as in the heavens. Thus, if we face south and turn the globes so that they move from right to left, that is, against the hands of a clock, they illustrate direct motion as seen in the northern hemisphere.

CHAPTER V.

THE SUN.

ALL the questions proposed in this chapter, and in those which follow, are designed to be answered directly by observation, or by data obtained from observation. In making reductions, or deriving checks, the celestial globe, or simple mathematical processes, should be employed.

The time used is eastern standard time, civil date, unless the contrary is explicitly stated.

QUESTIONS.

87. Noon altitude and sunset point.

1. What is the sun's altitude at noon and azimuth at setting on some day in September, near the autumnal equinox?
2. What values for these angles are obtained at intervals of three or four weeks from September 20 to June 20?
3. Is any variation in the sun's noon altitude detected in less than a week?
4. Judging from two or three observations taken in September, and two or three in December, does the variation in noon altitude appear to be uniform?
5. What value is obtained for the inclination of the ecliptic by measuring the sun's noon altitude at the solstices?
6. When the sunset point is moving south, how is noon altitude changing?
7. When this point is moving north, how is noon altitude changing?
8. What change is found in the sunset point when observations are separated by a week or ten days?
9. As determined by observations made in September and December, is the motion of the sunset point uniform?

10. Does this point ever appear to be stationary for a few nights?
11. What is the smallest and what the largest azimuth found for the sunset point?
12. Do observed times of sunset vary uniformly from night to night? How closely do they agree with the almanac times?
13. If the setting point of the sun is found, for example, to be 10° south of the west point, what is its amplitude at rising on the preceding or following morning?

88. Diurnal path.

1. What are the changes in the sun's altitude and azimuth in a given hour?
2. Which of these coördinates varies the more rapidly during the middle of the day?
3. Which is found to vary more rapidly an hour or two before sunset?
4. If diurnal paths of the sun are fixed by the points of rising, southing, and setting, what changes are noted between two paths observed in different months?
5. On a given day, what is the sun's hourly rate of motion in its diurnal path?
6. What is the highest meridian altitude and largest azimuth at setting obtained for the sun's path on any one day?

89. Annual path.

1. What constellation is seen near the horizon after sunset along the course which the sun has just traveled?
2. From month to month do you find the same constellation there?
3. In different months is the same constellation seen in the east in the sun's path just before sunrise?
4. According to these observations, in what direction does the sun appear to move among the stars?

90. Time.

1. How accurately can you determine time from an altitude and azimuth of the sun, measured with the Circles?

2. How accurately can you find apparent noon by taking the mean of two times when the sun is at the same angular distance east and west of the meridian?

3. What is the error of apparent noon found from the shadow of the gnomon on the noon mark?

4. What is the error of apparent noon found by the transit of the sun across two plumb lines placed in the plane of the meridian?

5. At any hour of the day how accurately is time read from a sun-dial?

91. Latitude.

1. What value for latitude is obtained from a single observation of the sun's noon altitude?

2. If noon altitude is measured at the solstices, what is the value found for latitude?

92. Shadows.

1. How does the noon shadow of a particular wall vary in length during a given month?

2. In general, what is the direction and what is the comparative length of shadows at morning, noon, and evening?

3. From the shadows of trees and buildings what can be learned about the sun's position with regard to the horizon?

4. In what part of the year are noon shadows notably long? notably short?

5. About March 21, or September 21, what is the direction of shadows when the sun is rising? When the sun is setting?

93. Face appearance.

1. Is any difference noted in the form and size of the sun when seen in different parts of the sky?

2. Is its size affected by looking at it through the transit tube?

3. At what times and under what conditions have you seen sun-dogs or mock-suns? How do you describe their appearance?

4. Is any variation seen in the color of the sun in one day, or from day to day?

5. Testing sunlight by its power to penetrate clouds, is there

any difference in that coming from the limb and from the centre of the sun ?

6. At the time of sun-spot maximum can you see any spot with the naked eye ? On what part of the sun is it located ?

94. "Spot of light" under trees.

1. When the sun is shining, what is the form of the spots of light seen under a tree with thick foliage ?

2. How can it be shown whether their shape is due to the form of the sun, or to the form of the aperture through which the light passes ?

3. Does the form of a spot vary if white paper or cardboard is held at different angles under the tree ?

4. Is the size affected by the height of the branches above the ground ?

5. Has the position of the sun with regard to the horizon any effect upon these spots of light ?

6. Under what conditions do distorted and overlapping forms appear ?

95. Duration of sunset.

1. How long does it take the sun to set, that is, how long is the interval between the disappearance of the lower and upper limbs ?

2. Does the interval vary in different months of the year ?

96. Sunset glow.

1. After the sun has set, how many degrees along the horizon does the sunset glow extend ?

2. What is the form of the section illuminated, and what height does it reach ?

3. How long is this light visible, and through what marked changes does it pass ?

97. Twilight.

1. What is the form, position, and color of the twilight bow ?

2. What is the color and position of the earth's shadow ?

3. Defining twilight as the interval between sunset and the appearance of sixth magnitude stars, how long does twilight last on a clear moonless evening in March or October? How long in June or July?

4. Taking the distinct appearance of the Milky Way to mark the end of twilight, how long does it last?

98. Zodiacal light.

1. In February or March what is the general appearance of the zodiacal light? What is its color?

2. How soon after sunset can it be seen? How long is it visible, and when is it brightest?

3. How high is it possible to trace this light, and how far along the horizon does it extend?

SUGGESTIONS AND ILLUSTRATIONS.

99. Protection for the eyes. — Whenever the sun is examined directly, care must be taken to protect the eyes. For this purpose a piece of colored or smoked glass may be held in the hand, but it is better to use spectacles with dark glasses, as they give steadier views and leave both hands free. One pair is usually sufficient if the glasses are smoked.

100. Altitude and amplitude from shadows. — About eight o'clock Friday morning, Jan. 31, 1896, at Northampton, Mass., an estimate was made of the sun's position from the shadow of a tree. From its foot two imaginary lines were drawn, the first being carried toward the north by prolonging the line of direction given by a north and south wall some thirty feet distant, and the second traced as nearly as possible perpendicular to the first.

This rough meridian line and prime vertical are represented by the lines *NS* and *WE* in Fig. 10, where *TL* gives the direction of the shadow, and *H* marks the intersection of the sun's vertical circle with the horizon.

Since opposite angles are equal, we can measure the sun's amplitude (§ 75) at the time of observation by the angle WTL . This angle which the shadow made with the prime vertical was determined by the eye. Twice it was called a third of the right angle WTN , formed by the two imaginary lines, and once less than a third, or 25° , giving a mean value of 28° .

Since at this time the shadows were long compared with those noticed the day before about noon, the observer concluded, without looking at the sun, that it was not far above the horizon, and about 28° south of the east point.

For the given hour and place the altitude and amplitude measured on the globe are 8° and 33° (§ 74, Ex. 2).

A numerical value for altitude may be derived by employing a tree as a rude gnomon (§§ 11, 101). Thus, at the place just mentioned, an old apple tree with a branch not far from the ground was chosen. The shadow cast by that part of the trunk below the branch was estimated to be 27 feet. First a space, which the eye judged to be a foot, was marked off on the snow along the line of the shadow, and then the space increased by the addition of a second and third "foot." With this measure of a yard in the mind's eye the whole length was divided into nine parts. The height of the trunk up to the branch was in like manner estimated to be $4\frac{1}{3}$ times the imaginary foot.

(H. W. B.)

In Fig. 11, AB represents the distance of the branch above the ground, BC the length of the shadow, and the oblique angle ACB measures the sun's altitude.

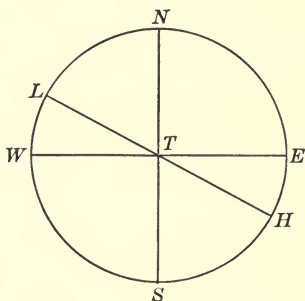

FIG. 10. — Azimuth from the Shadow of a Tree.

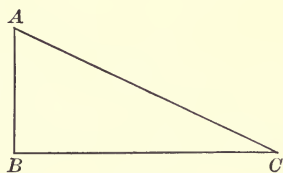

FIG. 11.

To find the angle from the sides we have, by trigonometry,

$$\tan ACB = \frac{AB}{BC},$$

or, substituting figures,

$$\tan ACB = \frac{4.3}{27} = 0.1593,$$

making the derived altitude of the sun $9^{\circ}.0$. Another observer at the same time made an independent determination by estimating the length of the shadow directly in terms of the height of the branch and obtained $9^{\circ}.9$ as the sun's altitude.

As the time was $8^{\text{h}} 25^{\text{m}}$ A.M., January 17, the altitude obtained from the globe is $9^{\circ}.5$ (§ 74, Ex. 2).

Instead of employing trigonometry to find such angles as these, we may lay off the sides in right proportion on rectangular paper and then measure the required oblique angle with a protractor.

101. Noon altitude. — Since the sun reaches the highest point in its diurnal path at noon, it is important to obtain its altitude at that time in order to gain even an approximate idea of the path for the day. Neither a meridian line nor instrumental aid is absolutely necessary, as is shown by the example immediately following.

OBSERVATION 1. — Smith College Observatory, Northampton, Mass.,* Saturday, Aug. 24, 1895. By means of a watch and a common almanac I found the approximate time of apparent noon (§ 37), and at that time held my right hand overhead, so that the forefinger pointed directly upward, and the second at right angles to it in the same plane. With the forefinger of the other hand this right angle was divided into equal parts of 45° . The sun's position was carefully noted and judged to be

* In designating this place of observation hereafter simply the letters S. C. O. are employed.

one third of the upper angle above the dividing finger, that is, the altitude of the sun was $15^\circ + 45^\circ$, or 60° . (A. E. T.)

While it is possible with practice to obtain fair results in estimating angular distances of the sun, some mechanical aid is needed more for this than for any other heavenly body, as in the daytime the stars do not serve as reference points in determining distance.

The quadrant, Circles, and gnomon were employed in measuring the sun's altitude in the observations which follow.

OBSERVATION 2.—S. C. O., Wednesday, Feb. 19, 1896. One of the home-made quadrants described in Section 13 was placed on the cross-piece of a gnomon post, set approximately in the meridian. The sides of the post gave a vertical support for both arms, and the lower one was kept horizontal by the cross-piece.

Since in the quadrant used the lines bounding the arms on the inside are those including the angle measured by the graduated scale, the eye was placed as nearly as possible at their intersection.

The upper arm was moved along the scale till its pointed end seemed to pierce the centre of the sun. For this position the reading on the scale gave one value of the altitude, and four additional readings made the mean value $38^\circ.0$. (A. J.)

When no supports are employed, an assistant should see that the quadrant is correctly placed at the eye and that the lower arm is horizontal; for the observer with spectacles dark enough to look directly at the sun cannot judge of the position of the instrument.

OBSERVATION 3.—S. C. O., Wednesday, Feb. 19, 1896. The Circles (§ 16) were placed on the first meridian stone on the south so that the points marked 0° and 180° were just above the meridian line on the stone.

After the base had been levelled by means of wooden wedges and a carpenter's level, the upright shaft was turned in its socket, and the pointer of the vertical circle raised and lowered

till its upper end appeared to eclipse the centre of the sun as seen by the eye at the lower end. The graduation on the circle then opposite the centre of the upper end of the pointer was read and recorded. In this manner five measures were made, giving a mean of $36^{\circ}.5$. (D. R. C.)

OBSERVATION 4. — S. C. O., Wednesday, Feb. 19, 1896. In order to find the sun's noon altitude from the gnomon, its shadow must be measured at apparent noon. This time was taken from the Ephemeris, reduced to sidereal time and a common watch set with the sidereal clock. When the watch showed the computed time, the end of the shadow was marked. Three independent measures of its length, made by laying a straight edge of wood on the crust of snow, gave 38.84 inches; and the mean of three measures of that part of the gnomon above the snow was 28.62 inches. (A. E. T.)

From the height of the gnomon and the length of the shadow, the altitude of the sun is determined as in Section 100. The figure given there is equally applicable here. ACB is the required angle of altitude, and the sides BC and BA are in this example 38.84 inches and 28.62 inches. Therefore,

$$\tan \text{alt.} = \frac{28.62}{38.84}, \text{ and altitude} = 36^{\circ} 23'.$$

It is not necessary to employ a sidereal clock. The time of apparent noon given in a common almanac may be taken with sufficient accuracy from a common watch or clock. Neither almanac nor watch is essential, if a meridian line has been carefully drawn and the gnomon placed in the same plane, for in that case the time of apparent noon is shown by the edge of the shadow coinciding with the meridian line.

102. Altitude at any hour of the day. — The altitude of the sun may be obtained by the unaided eye, or with instrumental appliances at any hour of the day, and observations may be made either with or without a meridian line.

OBSERVATION. — S. C. O., Wednesday, Feb. 12, 1896. — A pair of jointed rulers (§ 12) was placed on the wide sill of a south window, with the blunt ruler resting on the sill and the pointed one directed toward the sun.

In sighting, the angle of altitude was included between the outer edge of the pointed ruler and the inner edge of the other. With their direction unchanged, the rulers were laid on one of the circular protractors (§ 12) and the angle read off in degrees and tenths. The mean of five readings corresponding to 10^h 6^m.6 A.M. was 28°.4. (E. R.)

Doubtless the error in using so rude an instrument will be diminished if care is taken to hold the jointed rulers so that the lines including the required angle meet as nearly as possible at the pupil of the eye. As a test of the accuracy with which the angle is read from the protractor, we may mark on paper the bounding lines employed and see whether the angle formed by joining them is the same as that read directly.

TABLE V.—ALTITUDES OF THE SUN OBSERVED AT NORTHAMPTON, MASS.

| DATE. | INSTRUMENT. | OBSERVED ALTITUDE. | CHECKS FOR ALTITUDE. | |
|--|----------------|--------------------|----------------------|-------------|
| | | | FROM GLOBE. | FROM COMPT. |
| 1895 Aug. 24, noon | Naked eye | 60° | 58°.4 | 58° 43' |
| 1896 Feb. 19, noon | Quadrant | 38 .0 | | |
| “ “ “ | Circles | 36 .5 | 35 .9 | 36 25 |
| “ “ “ | Gnomon | 36 .4 | | |
| Feb. 12, 10 ^h 7 ^m A.M. | Jointed rulers | 28 .4 | 27 .0 | 27 42 |

103. Table of altitudes. — The five altitudes given in Sections 101 and 102 are brought together in Table V, which also includes checks derived from the globe and from calculation.

As usual, the checks from the globe were obtained by taking

the mean of three or more measures. The first and second numerical checks were found directly from the sun's declination at noon (§ 32), and the third is worked out in full, as follows.

EXAMPLE. — S. C. O., Wednesday, Feb. 12, 1896, the sun's declination was $-13^{\circ} 43'$ at $10^{\text{h}} 6^{\text{m}}.6$ A.M. What was its altitude at that time?

Since the declination is given and the hour-angle of the sun is apparent time, it is only necessary to reduce $10^{\text{h}} 6^{\text{m}}.6$ to apparent time (§ 50) before finding the zenith distance of the sun.

We have then:

| | |
|--|-----------------------------------|
| Standard time at Northampton, | 10 ^h 6 ^m .6 |
| Northampton east of the 75th meridian, | <u>9 .4</u> |
| Local time at Northampton, | 10 16 .0 |
| Equation of time, | <u>14 .4</u> |
| Apparent time, | 10 1 .6 |
| Astronomical time, | 22 1 .6 |

This hour-angle converted into degrees equals $330^{\circ} 24'$, and applying Formula (9) in Section 75 we have:

| | | |
|-------------------------|---|--|
| | $\log \tan \delta = \overset{n}{9.38754}$ | |
| $\phi = 42^{\circ} 19'$ | $\log \cos t = \overset{n}{9.93927}$ | $\log \tan t = \overset{n}{9.75441}$ |
| $M = -15 41$ | $\log \tan M = \overset{n}{9.44827}$ | $\log \cos M = 9.98352$ |
| $\phi - M = 58 0$ | $\log \tan(\phi - M) = 0.20421$ | $\log \operatorname{cosec}(\phi - M) = \overset{n}{0.07158}$ |
| $A = 327 11$ | $\log \cos A = \overset{n}{9.92449}$ | $\log \tan A = \overset{n}{9.80951}$ |
| $\zeta = 62 18$ | $\log \tan \zeta = \overset{n}{0.27972}$ | |

The complement of the zenith distance gives the required altitude $27^{\circ} 42'$, and this is the value entered above in the table. All of the numerical checks would be more strictly comparable with the observed values if increased by refraction, but the correction would in no case exceed $2'$.

104. Azimuth at sunset. — In following the diurnal motion of the sun, the determination of azimuth at rising or setting is

scarcely less important than finding the noon altitude. Thus, it is a matter of interest to note several methods which may be employed.

OBSERVATION 1. — S. C. O., Monday, Aug. 26, 1895. A little before the sun set, the south and west points of the horizon were located approximately by extending the left arm in the plane of the meridian and the other at right angles to it. The lines of direction thus marked out were followed till they reached the horizon. There a particular chimney located the south point, and a limb of a small elm tree the west point. The 90° between the two was divided into thirds by the eye and marks of division fixed by trees. The angular distance of the sun north of the west point was then estimated in terms of the division nearest that point. Once this distance was called two thirds of 30° and twice one half, or the values for azimuth were 110° , 105° , and 105° , giving a mean of 107° .

In direct eye estimates it is usually difficult to deal with a smaller unit than 5° in a single measure. But if the west point has been determined, and the sun at setting is near that point, its amplitude may be given in terms of its own diameter; that is, to half degrees (§ 6).

OBSERVATION 2. — S. C. O., Thursday, June 11, 1896. The jointed rulers were held in the hand without any support, their position at the eye and in the plane of the horizon being checked by an assistant.

As the sun was far to the north of the west point, the blunt ruler was directed toward the north point of the horizon, and the other to the centre of the sun. Three measures gave a mean of $58^\circ.3$, corresponding to an azimuth $121^\circ.7$. (S. M. M.)

OBSERVATION 3. — S. C. O., Thursday, April 16, 1896. The Circles were placed and adjusted as for altitude (§ 101, Obs. 3), and when the pointer of the vertical circle seemed to pierce the sun, the lower pointer on the horizontal circle designated the azimuth for that instant.

On account of hills and trees, the sunset came so long before almanac time that only two observations were taken. Their mean, $104^{\circ}.2$, corresponded to $6^{\text{h}} 22^{\text{m}}$ P.M. (A. B. D.)

105. Table of azimuths. — Table VI, which follows, includes the azimuths at sunset given in the preceding section, and also an additional value found at another hour of the day.

TABLE VI.—AZIMUTHS OF THE SUN OBSERVED AT NORTHAMPTON, MASS.

| DATE. | INSTRUMENT. | OBSERVED AZIMUTH. | CHECKS FOR AZIMUTH. | |
|---|----------------|-------------------|---------------------|-----------------|
| | | | FROM GLOBE. | FROM COMPT. |
| 1895 | | | | |
| Aug. 26, sunset | Naked eye | 107° | $103^{\circ}.6$ | $103^{\circ}.9$ |
| 1896 | | | | |
| June 11, sunset | Jointed rulers | 121 .7 | 121 .6 | 122 .2 |
| April 16, sunset | Circles | 104 .2 | 103 .6 | 104 .4 |
| Sept. 23, $8^{\text{h}} 56^{\text{m}}$ A.M. | Circles | 307 .3 | 307 .7 | 307 .4 |

In the fourth column the checks for sunset were obtained by reading azimuth from the globe when the mark for the sun had been brought into the plane of the horizon plate. For the other observation the globe was oriented as usual for the given time (§ 68). The numerical checks at the time of sunset were derived by Formula (7), Section 75, and Formula (9) in the same section was employed for the morning observation.

To illustrate the calculation of these checks, and to show at the same time the difference in the values obtained by different methods, let us find the place of sunset, in three ways for April 16, 1896.

As we have seen already, amplitude is easily converted into azimuth (§ 75, Ex. 1), so we take first the simple formula :

$$\sin a = \sec \phi \sin \delta. \quad (7)$$

The latitude of the place is $42^{\circ} 19'$ (Appendix E), and the sun's declination, taken from the Ephemeris for the theoretical time of sunset given in a common almanac, is $10^{\circ} 34'$.

The required logarithms, with their corresponding angles, are then :

| | |
|-----------------------------|------------------------------------|
| $\delta = + 10^{\circ} 34'$ | $\log \sin \delta = 9.26335$ |
| $\phi = 42 19$ | $\log \sec \phi = 0.13110$ |
| $a = 14 22$ | $\log \sin a = \overline{9.39445}$ |
| $A = 104 22$ | |

Employing next the formula which includes refraction,

$$\cos \frac{1}{2} A = \sqrt{\frac{\cos \frac{1}{2} [\zeta + (\phi + \delta)] \sin \frac{1}{2} [\zeta + (\phi - \delta)]}{\sin \zeta \cos \phi}}$$

we have the same values for ϕ and δ as given above, and ζ , the sun's zenith distance at setting, is $90^{\circ} + 16' + 36'$, or $90^{\circ} 52'$ (§ 40); whence the following calculation is made :

| | |
|------------------------------------|---|
| $\phi = 42^{\circ} 19'$ | $\log \sec \phi = 0.13110$ |
| $\zeta = 90 52$ | $\log \operatorname{cosec} \zeta = 0.00005$ |
| $\phi + \zeta = 133 11$ | $\log \cos \frac{1}{2} \text{sum} = 9.49308$ |
| $\delta = 10 34$ | $\log \sin \frac{1}{2} \text{diff.} = \overline{9.94307}$ |
| $\frac{1}{2} \text{sum} = 71 52$ | $\overline{19.56730}$ |
| $\frac{1}{2} \text{diff.} = 61 18$ | $\log \cos \frac{1}{2} A = \overline{9.78365}$ |
| $A = 105 10$ | |

The third formula (§ 75) for finding the azimuth of a heavenly body is :

$$m \sin M = \sin \delta \quad \tan M = \frac{\tan \delta}{\cos t} \quad \tan A = \frac{\tan t \cos M}{\sin (\phi - M)}$$

where t , the hour-angle, is the only new factor required. It is found from the time of sunset, $6^{\text{h}} 34^{\text{m}}$, used in the preceding examples, to be $100^{\circ} 57'$ (§ 103, Ex.), and hence we have :

| | | | | |
|--------------|---------------|----------------------|---------------------|--|
| $\delta =$ | 10° 34' | $\log \tan \delta =$ | 9.27078 | |
| $\phi =$ | 42 19 | $\log \cos t =$ | $\frac{n}{9.27864}$ | $\log \tan t =$ |
| | | | | $\frac{n}{0.71338}$ |
| $M =$ | <u>135 31</u> | $\log \tan M =$ | $\frac{n}{9.99214}$ | $\log \cos M =$ |
| | | | | $\frac{n}{9.85337}$ |
| $\phi - M =$ | - 93 12 | | | $\log \operatorname{cosec} (\phi - M) =$ |
| | | | | $\frac{n}{0.00068}$ |
| $A =$ | 105 9 | | | $\log \tan A =$ |
| | | | | $\frac{n}{0.56743}$ |

The last two checks agree closely, as we should expect, for the declination is the same, and in one refraction enters directly, and in the other its effect is virtually included in the hour-angle taken for sunset. While these checks are theoretically more accurate than the first, that one gives a fairer test of the observation, since the omission of refraction tends to counteract the effect of the elevated horizon line (§ 107).

106. Diurnal path without instrumental aid.— To follow the path of the sun from month to month and note its changes with the changing seasons is one of the most interesting problems open to naked-eye observers.

A fair idea of the path for any one day may be obtained by locating the points at which the sun rises, souths, and sets; and since the main object is not to fix an individual path with the utmost precision, but rather to compare different paths, we may dispense with instruments and meridian lines.

OBSERVATION 1.— Round Hill, Northampton, Mass., Friday, Feb. 4, 1898. On this hill a place was found, from which sunrise and sunset were both visible. The exact spot chosen was opposite Mr. Williston's grounds, at the eighth post below the gate. Watched from this position, the sun rose at 7^h 12^m, at a point marked by a tree on the Mt. Holyoke range (3, in Fig. 12). When entirely above the horizon, it had moved about one half its diameter to the south.

The sun's altitude, at noon on the same day, was determined by a tree not far from the post mentioned above. Its lowest

branch was estimated to be $4\frac{2}{3}$ feet above the ground, and the length of the shadow cast by the trunk below the branch was called $6\frac{1}{2}$ feet. So, according to these estimates, the altitude was 36° (§ 100).

Observed from the same place as in the morning, the sun was seen to set at $5^h 2^m$. The particular point was about half the sun's diameter north of a clearly defined notch in the line of the western hills.

Facing the southern sky with these three points in mind, it was easy for the observer to trace in imagination the sun's path for the day. It intersected the eastern horizon at the fourth notch northward from the Mountain House on Mt. Holyoke, crossed the meridian at a point a little more than a third of the distance from horizon to zenith, and met the western hills close to the notch still lighted by the sunset. By prolonging the north and south line fixed by the noon shadow it was clearly seen that sunrise and sunset came nearer the south than the north point of the horizon. Hence, on February 4, the sun rose and set south of the east and west points.

(H. W. B.)

About a month later, on March 7, at the same place, the same observer traced the sun's path again, and found that the time of rising was $6^h 20^m$, and the meridian altitude 45° .

Cloudy weather prevented observations exactly at the spring equinox, but two days before, on March 18, a third path was fixed under like conditions as those described above. On that date the sun rose at $6^h 1^m$, reached a noon altitude of 48° , and set about $5^h 55^m$.

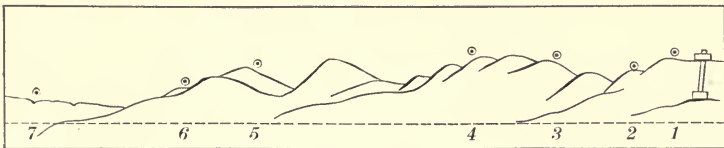

FIG. 12. — Change in Sunrise Point.

The times recorded are only slightly affected by errors in the watch employed, as it was frequently compared with the daily time signals. The three positions of sunrise already mentioned, as well as several others, are shown in Fig. 12, where the eastern horizon is marked by a rough outline of the Holyoke range.

The numbers given in connection with the symbols correspond to the following dates:

| | |
|---------------|------------|
| 1. January 25 | 5. March 2 |
| 2. " 28 | 6. " 7 |
| 3. February 4 | 7. " 18 |
| 4. " 14 | |

The arc of the horizon between the points 3 and 7 was estimated to be a fourth of a quadrant, and the corresponding sunset points appeared to be separated by practically the same amount. Thus, from the data at hand, we conclude that during six weeks the sunrise and sunset points moved north about 22° , noon altitude increased 12° , and the day lengthened by about two hours.

107. Diurnal path determined with the Circles.— While we can obtain a general idea of the sun's path for any day by locating two or three critical positions, a far larger number is required to trace accurately the entire curve above the horizon.

In order to illustrate such a path, measures of altitude and azimuth were made at short intervals during the astronomical day, Aug. 28, 1896, at Northampton, Mass. Near the observatory at this place there is unfortunately no good horizon for naked-eye work. The building itself obstructs the view either on the north or south, and toward the east there are buildings and trees only a few rods distant. The western horizon is better, but the hills and trees there are above the observing ground.

Resort was had, therefore, to the following device in fixing the point of sunrise.

The Circles were placed and adjusted as for Observation 3, Section 101, and the altitude and azimuth of the sun measured as soon as it appeared above the roof of the Wallace House. Half an hour later, the pointers having been left undisturbed, they still marked the first position of the sun, and a second one higher up was given by the sun itself. The imaginary line drawn through these points appeared to meet the plane of the horizon at the southeast corner of the Wallace House. This intersection, therefore, was taken as the sun's place on the horizon, and three independent measures of its azimuth gave the angle, which is entered in brackets in the following table of altitudes and azimuths.

TABLE VII.—POSITIONS OF THE SUN, AUG. 28, 1896,
NORTHAMPTON, MASS.

| TIME. | ALTITUDE. | AZIMUTH. | REMARKS. |
|-------------------|-----------|----------|----------------------------------|
| 2h 0 ^m | 48°.7 | 49°.6 | |
| 2 59 | 38 .6 | 65 .2 | |
| 4 0 | 28 .1 | 77 .4 | |
| 5 0 | 15 .7 | 88 .0 | |
| 5 59 | 4 .8 | 97 .6 | |
| 6 15 | 2 .0 | 100 .2 | Sunset observation. |
| [17 27] | | [261] | |
| 18 16 | 10 .7 | 266 .9 | Sun first seen in the morning. |
| 18 58 | 18 .6 | 273 .8 | |
| 19 55 | 28 .9 | 284 .7 | |
| 21 3 | 41 .4 | 298 .8 | |
| 22 1 | 49 .8 | 315 .4 | |
| 23 0 | 55 .4 | 338 .5 | |
| 23 52 | 58 .2 | 1 .0 | |
| 25 4 | 53 .3 | 30 .6 | New pointer for vertical circle. |

Each angle in the table, with the exception of the bracketed value, is the mean of four measures made with the Circles, and

the corresponding time is the mean of the times of the individual measures. The watch employed in recording was not in error during the observations more than one or two tenths of a minute, as shown by comparing it with the daily time signals. The method of obtaining the time of sunrise is explained in the following section.

108. Sunrise and sunset for August 28. — Since the points of sunrise and sunset for August 28 were determined by measuring azimuth, or altitude and azimuth, the times of rising and setting may be derived from these coördinates, either by reading hour-angles directly from the globe or by computing them. We may also calculate purely theoretical values.

EXAMPLE. — Find the local mean time of sunrise in four different ways for August 28, astronomical date, 1896, Northampton, Mass.

In order to obtain the required time from the celestial globe, we locate the sun by the coördinates 0° , 261° (Table VII). Between the sun's place thus fixed and the graduated face of the meridian ring there are about 6.5 hour-spaces. The fractional part of an hour, read more carefully with a narrow strip of paper for an hour-circle (§ 76), is 26^m . From the globe, then, we have the apparent time of sunrise $5^h 34^m$ (§ 42).

As in estimating the sun's place of rising its altitude was called zero, Formula (4) in Section 40 is the one to be employed in calculating the hour-angle from the observation. Hence we have:

$$\begin{array}{llll}
 \log(-\cos \phi) = \overset{n}{9.8690} & \log \sin \phi = 9.8280 & & \\
 \log \cos A = \overset{n}{9.1943} & \log \cos A = \overset{n}{9.1943} & \log \sin A = \overset{n}{9.9946} & \\
 \log \sin \delta = \overset{n}{9.0633} & \log \sec \delta = \overset{n}{0.0029} & \log \cos \delta = \overset{n}{9.9971} & \\
 t = -96^\circ = -6^h 24^m & \log \cos t = \overset{n}{9.0252} & \log \sin t = \overset{n}{9.9975} &
 \end{array}$$

From this hour-angle the local mean time is derived:

| | | |
|------------------|---|--------------------------------|
| Hour-angle | = | 6 ^h 24 ^m |
| Apparent noon | = | 12 0 |
| Apparent time | = | <u>5 36</u> |
| Equation of time | = | 0.6 |
| Local mean time | = | <u>5 36.6</u> |

Hence the standard time of sunrise, 5^h 27^m, or 17^h 27^m, is the value found above in Table VII.

The simplest means for obtaining the theoretical time of sunrise is given by a table of semi-diurnal arcs. The arguments required are latitude and declination. The latitude of the place we know is 42°.3, and the approximate declination of the sun when rising on the given date is +9°.1 (§ 44). We find, then, by interpolating from Table XIX, of Loomis's "Practical Astronomy," an east hour-angle 6^h 33^m.

A more accurate determination of the theoretical time is made by Formula (6), Section 40, as follows:

| | | |
|---|---------------------------------------|-----------------|
| $\phi = 42^\circ 19'$ | $\log \sec \phi$ | = 0.13110 |
| $\delta = + 9 7$ | $\log \sec \delta$ | = 0.00552 |
| $\phi - \delta = \frac{33 12}{\quad}$ | $\log \sin \frac{1}{2} \text{ sum}$ | = 9.94607 |
| $\zeta = 90 52$ | $\log \sin \frac{1}{2} \text{ diff.}$ | = 9.68328 |
| $\frac{1}{2} \text{ sum} = 62 2$ | | <u>19.76597</u> |
| $\frac{1}{2} \text{ diff.} = 28 50$ | $\log \sin \frac{1}{2} t$ | = 9.88298 |
| $t = -99 36, \text{ or } -6^{\text{h}} 38^{\text{m}}.4$ | | |

All these hour-angles, like the second, having been reduced to local mean time, are brought together in Table VIII. The times of sunset, also given there, were derived by the same methods just illustrated for sunrise, except that Formula (5), instead of (4), Section 40, was used in calculating the sunset from observation.

In the last column of the table are added the times obtained from the Old Farmer's Almanac.

TABLE VIII.—LOCAL MEAN TIME OF SUNRISE AND SUNSET, AUG. 28, 1896, NORTHAMPTON, MASS.

| | FR. OBSERVED AZIMUTH. | | FROM SEMI-DIURNAL ARCS. | FROM THEORET. FORMULÆ. | FR. OLD FARMER'S ALMANAC. |
|---------|--------------------------------|--------------------------------|--------------------------------|-----------------------------------|--------------------------------|
| | GLOBE. | COMPUTED. | | | |
| Sunrise | 5 ^h 35 ^m | 5 ^h 37 ^m | 5 ^h 28 ^m | 5 ^h 22 ^m .2 | 5 ^h 22 ^m |
| Sunset | 6 23 | 6 23 | 6 35 | 6 39 .9 | 6 39 |

109. Length of the day, August 28.—The difference, 13^h 18^m, between the times of sunrise and sunset, given in the fifth column above, is the theoretical length of the day. The actual length derived from column three is 12^h 46^m. At first thought, it would seem as if this difference of half an hour could be accounted for by the bad horizon on the east (§ 107). But reference to Table VIII shows that actual and theoretical sunset differ as much as actual and theoretical sunrise. Thus, while a large error in estimating sunrise is not surprising, the discrepancy in sunset between theory and observation requires attention. From Table VII we see that when the sun set to an observer on the meridian stone, it had an altitude of 2°; and, moreover, the records of several years give approximately the same altitude when sunset has been observed from this position. Therefore we ought not to expect the real and theoretical times to agree. Indeed, calculation shows that for August 28 the sun's hour-angle, when it passed below the true horizon, was 14^m larger than the hour-angle obtained when it had an altitude of 2°.

So, in the end, we conclude that whether the sun's place on the horizon is estimated or observed at the given place, there may be sufficient difference between the true and the visible horizon to change the length of the day by about half an hour.

110. Hourly rate of apparent motion.—If, at two different times, observations have been taken of the sun from which

hour-angles can be computed, we have the data for determining the rate of apparent motion.

As an illustration let us take from Table VII the coördinates measured at $18^{\text{h}} 16^{\text{m}}$ and at $25^{\text{h}} 4^{\text{m}}$. From the altitude $10^{\circ}.7$ and azimuth $266^{\circ}.9$ for the first position, the sun's hour-angle is found to be $-84^{\circ}.2$, and from the later observation we obtain the hour-angle, $+18^{\circ}.0$. Now the difference between these angles gives the sun's motion measured on the celestial equator during the interval of $6^{\text{h}} 48^{\text{m}}$ between the recorded times of the two observations. Therefore, by dividing $102^{\circ}.2$ by 6.8 we obtain the hourly rate of apparent motion, $15^{\circ}.0$, which agrees with the theoretical value.

111. Graphic representation of the diurnal path.—A graphic representation of the sun's diurnal path may be made in three different ways. The easiest method, illustrated in Fig. 13, consists in plotting the observed positions on paper.

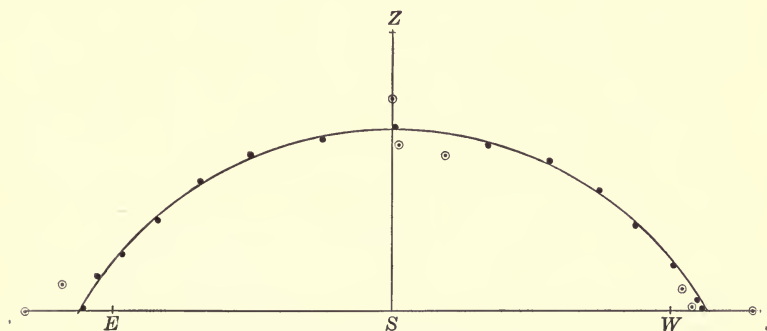

FIG. 13. — Diurnal Path of the Sun.

In the figure the zenith point is marked Z , and E , S , and W fix the three cardinal points, east, south, and west. Taking the lines ZS and EW as coördinate axes, the different positions of the sun given in Table VII were located by laying off altitudes as ordinates, and azimuths as abscissas. Through the

fifteen points thus fixed a smooth curve was drawn which is found to be symmetrically placed with regard to the meridian.

The dots enclosed in circles below the curve mark points in the sun's diurnal path on September 11, and those lying above the curve give positions of the sun for July 25. Thus, it is evident that between July and September the sun's noon altitude was decreasing and the points of sunrise and sunset were moving toward the south point of the horizon.

In order to trace the path of the sun on the celestial globe its mean place for August 28 was made to coincide with the graduated face of the meridian ring, and the globe secured in that position. With the help of narrow strips of paper for vertical circles all of the observed places of the sun for the day (Table VII) were plotted, and marked by dots on bits of paper pressed upon the surface. These points, excepting that for sunrise, which was not obtained directly, were found to be within a degree of the 10° -parallel of north declination. From the observations, then, we may conclude that the sun's path on August 28 was approximately a circle. It could not have been a great circle, as the points determining it on the globe were 80° from the north pole and 100° from the south pole. The latter conclusion may, however, be drawn directly from the observations themselves, as the points of sunrise and sunset were separated by 160° or 200° instead of 180° .

We may obtain a third illustration of the sun's diurnal path from a slated globe. It should be oriented for the latitude of the place, and three observed positions plotted as on the celestial globe. The circle drawn through these points gives the required path, but this method involves the assumption that the sun's daily motion is in a circle.

112. Time of apparent noon. — In order to find the time of the sun's meridian transit, we may note the hour and minute when it is a certain number of degrees east of the meridian, measured

on a horizontal circle; and in like manner record the time when it has reached the same number of degrees west of the meridian. The mean of the two gives the time of southing or apparent noon.

OBSERVATION 1. — S. C. O., Wednesday, Sept. 23, 1896. The Circles were placed on the second meridian stone on the south, adjusted and carefully levelled. About 20^m before noon three measures of azimuth were taken, and soon after the sun was clearly by the meridian, readings were made at short intervals. When the angle west of the meridian agreed closely with that measured to the east, the second observation was begun. The complete record is as follows:

| Standard Time. | Azimuth. |
|---|---------------|
| 11 ^h 12 ^m 54 ^s | 351° .2 |
| 11 14 18 | 352 .6 |
| 11 15 47 | 351 .5 |
| Mean = <u>11 14 20</u> | <u>351 .8</u> |
| 12 1 33 | 8 .4 |
| 12 3 0 | 9 .0 |
| 12 3 54 | 8 .4 |
| Mean = <u>12 2 49</u> | <u>8 .6</u> |

The mean of these two means made the time of apparent noon according to the watch employed 11^h 38^m 34^s.

Knowing the longitude from the standard meridian and the equation of time for the day, we find the standard time of apparent noon to be 11^h 42^m 36^s, making the watch 4^m 2^s slow. But the error of the watch obtained by comparing it with the sidereal clock was only 3^m 21^s (§ 54), so that the observed time was in error 41^s.

The following observations show that more accurate determinations of apparent noon can be made with the transit tube and the gnomon.

OBSERVATION 2. — S. C. O., Tuesday, Jan. 19, 1897. The transit tube and stand (§ 18) were placed on the south merid-

ian stone, and both adjusted so that the plumb lines fell freely through the slots and the points of the bobs came to rest over the centre of the meridian line. To prevent a slight breeze from disturbing the lines, the bobs after being adjusted were put into 8-inch glass jars filled with water.

Though two pairs of dark spectacles were used during the observation, the lines were distinctly visible within the tube; and when the advancing edge or limb of the sun appeared to touch the two superimposed, an assistant who was holding my watch recorded time as I gave the word. In like manner the times were noted when the centre of the sun and the second limb came in contact with the lines. The times are:

| | |
|------------------------|--|
| First limb, | 11 ^h 57 ^m 0 ^s |
| Centre, | 11 58 50 |
| Second limb, | 12 0 13 |
| Mean, | <u>11 58 41</u> |

As the standard time of apparent noon for the day was 12^h 1^m 43^s (§ 37), the observation made the watch 3^m 2^s fast, but an independent determination of its error showed it to be only 2^m 52^s fast, making the error of the observation 10^s. (L. H. W.)

OBSERVATION 3.—S. C. O., Thursday, April 30, 1896. The gnomon shaft was put in position by placing it in the narrow box set in the ground at the south end of the north meridian stone (§ 11). Adjustments made with wedges and a carpenter's level brought its east edge into the plane of the meridian and at right angles to the stone. When the shadow cast by this edge coincided with the meridian line, and marked apparent noon, the corresponding watch time was 11^h 47^m 38^s.

We have then:

| | |
|--|---|
| Standard time of apparent noon by watch, | 11 ^h 47 ^m 38 ^s |
| Northampton east of the 75th meridian, | <u>9 27</u> |
| Local mean time of apparent noon by watch, | 11 57 5 |
| “ “ “ “ “ “ “ Ephemeris, | <u>11 57 0</u> |
| Combined error of watch and observation, | 5 |

Since the watch was 1^s fast at this time, the error of the observation was 4^s, a closeness of agreement doubtless owing in part to accident. (A. E. T.)

113. Time at any hour of the day. — The shadow on the sundial gives apparent time at any hour of the day, and theoretically considered time may be derived from any altitude or any altitude and azimuth of the sun. We find in practice, however, that these angles give more accurate results if measured at certain hours and dates; since the effect of an error in altitude or azimuth varies largely according to the value of declination and zenith distance (see Obs. 1), or according to declination and azimuth.

OBSERVATION 1. — S. C. O., Friday, Oct. 9, 1896. A little before the sun set, four measures of its altitude were made with the Circles, giving a mean value of 4° 51', or 4° 41', when corrected for refraction (Chauvenet, Table I).

According, then, to the method given in full in Section 108, we find the sun's hour-angle to be 5^h 9^m 28^s, whence standard time is obtained as follows:

| | |
|-----------------------------------|---|
| Sun's hour-angle = apparent time | = 5 ^h 9 ^m 28 ^s |
| Equation of time | = $\frac{12\ 59}{}$ |
| Local mean time | = 4 56 29 |
| Northampton east of 75th meridian | = $\frac{9\ 27}{}$ |
| Standard time | = 4 47 2 |

The true standard time derived from the Ephemeris and sidereal clock was 38^s earlier.

By referring to the Formula (§ 40 (6)) employed in finding the hour-angle above, we see that when the second angle of the numerator, $\frac{\zeta - (\phi - \delta)}{2}$, is small, a slight variation in the zenith distance appears with enlarged effect in the final time. Thus, in the present example, although $\frac{\zeta - (\phi - \delta)}{2}$ is 18°, a

change of $5'$ in ζ , either way, changes the time by nearly half a minute.

OBSERVATION 2. — S. C. O., Saturday, June 19, 1897. This afternoon Circles No. 3, having been placed on the second meridian stone on the south, were brought accurately into the meridian with the help of a small carpenter's square and made approximately horizontal by means of wedges and a carpenter's level. To aid as far as possible in eliminating instrumental errors (§ 3), altitude and azimuth were read with the vertical circle facing in opposite directions, and the graduations at each end of the horizontal pointer were also included. The times and angles copied from the observing book are:

| Time. | Altitude. | Azimuth. | | Circle. |
|--|------------------|-------------------|--------|---------|
| 5 ^h 51 ^m 50 ^s | 16°.5 | 107°.4 | 287°.3 | S. |
| 53 55 | 16.0 | 107.6 | 287.6 | " |
| 5 55 5 | 14.7 | 108.3 | 288.1 | N. |
| 56 33 | 14.6 | 108.4 | 288.3 | " |
| <u>5^h 54^m 21^s</u> | <u>15° 27'.0</u> | <u>107° 52'.5</u> | | |

As the sun was west of the meridian, its azimuth is given directly in the third column. From the other values 180° must be subtracted before obtaining the final mean.

Calculating the hour-angle by Formula (5), Section 40, we have:

$$\begin{array}{rcll}
 & \log \tan \zeta & = 0.56021 & \\
 \phi = 42^\circ 19'.0 & \log \cos A & = \underline{9.48706} & \log \tan A = \overset{n}{=} 0.49145 \\
 M = \underline{-48 \quad 6.7} & \log \tan M & = \underline{0.04727} & \log \sin M = \overset{n}{=} 9.87183 \\
 \phi - M = 90 \quad 25.7 & \log \tan(\phi - M) & = \overset{n}{=} 2.12640 & \log \sec(\phi - M) = \overset{n}{=} 2.12641 \\
 t = 90 \quad 11.1 & \log \cos t & = \underline{7.50890} & \log \tan t = \overset{n}{=} 2.48969 \\
 \delta = 23 \quad 21.3 & \log \tan \delta & = 9.63530 &
 \end{array}$$

The declination is checked directly by comparing it with the Ephemeris value, which is $+23^\circ 26'.9$. The time, $5^h 52^m$

30^s P.M., deduced as usual from the hour-angle, is shown by an independent determination to be 23^s fast. (H. W. B.)

OBSERVATION 3. — S. C. O., Saturday, Oct. 10, 1896. About two hours before apparent noon, the gnomon was adjusted as for Observation 3, Section 112. Since at this time in the morning the shadow extended beyond the meridian stone, a straight edge of wood was laid down along its line of direction and carefully levelled. Three times within a few minutes the end of the shadow was marked and a mean length of 98.86 inches obtained. Three measures were also made of the height of the upright above the straight edge of wood, and from these two means the sun's altitude was found to be 30° 57'.4 (§ 100).

Having altitude, we obtain hour-angle and standard time as in Observation 1. This time, 9^h 14^m 29^s A.M., is found to be 24^s fast when compared with the true time of the observation. (H. W. B.)

OBSERVATION 4. — S. C. O., Wednesday, Sept. 23, 1896. The sun-dial was set on the first meridian stone on the south, its base levelled and the noon line brought over the meridian line. By means of the adjusting screws and wooden pattern the style was placed at an altitude of 42°.3 and its position in the plane of the meridian tested by a short plumb line (§ 17).

When the shadow of the style lay centrally over the eleven-hour line of the dial face, sun-dial time was recorded, 11^h 0^m 0^s. Since the corresponding watch time reduced to apparent time equalled 10^h 56^m 42^s, the observation made the error of the watch + 3^m 18^s (§ 69). But its true error was + 3^m 25^s and so the sun-dial time was 7^s slow.

114. Latitude from any meridian altitude. — When the declination of the sun is known, its altitude at noon may be employed in finding the latitude of the place.

EXAMPLE 1. — On Saturday, Sept. 28, 1895, measures of the sun's noon altitude taken at Northampton, Mass., with a home-

made quadrant (§ 101) gave as a mean 45° . What was the observer's latitude?

At noon, on the Washington meridian, the sun's declination was $-2^\circ.1$, and as the difference in longitude is small the value to tenths is the same for Northampton noon (§ 41). If, then, the meridian altitude of the sun is 45° , and it is at the same time $2^\circ.1$ below the celestial equator, the meridian altitude of the equator must be $47^\circ.1$. Since the complement of this angle is the declination of the zenith, or the required latitude, the observation makes the latitude of Northampton $42^\circ.9$, that is, $0^\circ.6$ too large.

No account need be taken of refraction in this example, as it was much less than a tenth of a degree.

EXAMPLE 2. — The sun's noon altitude determined by the Circles and the gnomon at Northampton, Feb. 19, 1896, was $36^\circ 30'$ and $36^\circ 23'$ (§ 101). Find the corresponding values for latitude.

The brief reduction required may be arranged thus :

| | | |
|-------------------------------|----------------|----------------|
| Observed altitude of the sun, | $36^\circ 30'$ | $36^\circ 23'$ |
| Refraction, | 1 | 1 |
| Corrected altitude, | $36 29$ | $36 22$ |
| Declination of the sun, | $- 11 16$ | $- 11 16$ |
| Meridian altitude of equator, | $47 45$ | $47 38$ |
| Zenith distance of equator, | $42 15$ | $42 22$ |

By giving equal weight to these results the latitude derived is $42^\circ 18'.5$, agreeing with the true value within a minute (Appendix E).

115. Latitude from meridian altitude at the equinoxes. — At the time of either equinox the sun is on the celestial equator, and if apparent noon came at the same instant, the sun's zenith distance measured then would give directly the declination of the zenith or the latitude of the place. But while zero declination lasts but a moment, the change is small during the day of the

equinox, and even if the day before and the day after are included, the sun is usually found within half a degree of the equator. Hence, without knowing declination, approximate determinations of latitude may be made on any one of the three days.

OBSERVATION. — S. C. O., Wednesday, Sept. 23, 1896. After the gnomon shaft had been put in place at the south end of the north meridian stone (§ 112), the following measures were taken to determine the sun's altitude:

| Height of Post. | Length of Shadow. |
|-----------------|-------------------|
| 60.65 inches | 55.05 inches |
| 60.65 “ | 55.07 “ |
| 60.62 “ | 55.06 “ |
| Mean, 60.64 “ | 55.06 “ |

The tangent of the required angle is $\frac{60.64}{55.06}$, or 1.1013, and the altitude obtained, $47^{\circ} 46'$. This altitude corrected for refraction makes the latitude of the place $42^{\circ} 15'$. (A. E. T.)

116. Latitude from meridian altitudes at the solstices. — If the sun's altitude is observed at noon on the day of the winter and of the summer solstice, the mean of the corresponding zenith distances equals the latitude of the place. Instead, however, of observing on one day only, it is better to include the altitudes of several days, especially as the sun's declination changes slowly at the solstices.

OBSERVATION 1. — Brookside Farm, Olcott, Vt., Monday, Dec. 23, 1895. The sun's altitude was determined by measuring the length of a shadow cast at noon by an upright post on the floor of a porch. A strip of wood nailed at right angles to the post served to fix the limit of the shadow employed. Since the time of apparent noon was not known exactly, the end of the shadow was marked at several points on a large sheet of paper fastened on the floor. Through the mark which corresponded approximately to the time of apparent noon, the arc of

a circle was drawn with a radius equal to the distance between the mark and the foot of the post. For a few minutes the end of the shadow did not deviate perceptibly from this arc, but it extended beyond it both before and after this interval; and so the radius of the circle was taken as the length of the shadow at noon; for at noon the shadow is shortest and changes slowly.

The mean of three measures of the length of the shadow and the height of that part of the post employed were 104.6 and 44.9 inches, respectively; whence we derive an altitude for the sun of $23^{\circ} 14'$, or correcting for refraction, $23^{\circ} 12'$. (L. C. H.)

OBSERVATION 2.—Brookside Farm, Saturday, June 20, 1896. The sun's noon altitude was obtained from the same porch and in the same manner as in December. But in June the height of the post used was 36.0 inches, and its shadow was only 13.4 inches in length, making the sun's altitude $69^{\circ} 35'$. Observations were also obtained on the 18th and 24th of the month, and the mean of the three, $69^{\circ} 37'$, is taken as the meridian altitude of the sun at the time of the summer solstice. For

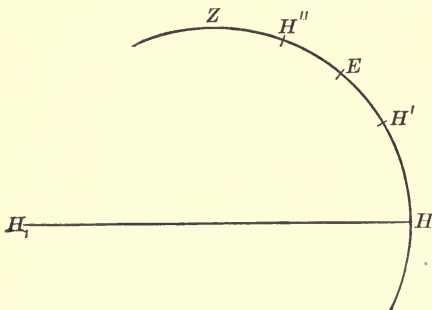

FIG. 14.

this altitude refraction is less than a minute, and so is neglected. (L. C. H.)

Having, then, the sun's altitude at each solstice, we see from Fig. 14 how latitude is derived.

Let HH represent the horizon line, and ZH the celestial meridian, Z being the zenith point and E the

intersection of the equator and meridian. Since the declination of the zenith equals the latitude of the place, the arc ZE is the measure of the required latitude.

The zenith distances ZH' and ZH'' are known because they are complements of the observed altitudes $H'H$ and $H''H$, and

as the sun goes as far above the equator in June as below it in December, EH'' equals EH' . Thus we have:

$$\begin{aligned} ZH' - EH' &= ZE \\ ZH'' + EH'' &= ZE \\ \hline ZH' + ZH'' &= 2 ZE \end{aligned}$$

That is, the sum of the two zenith distances of the sun at the time of the solstices is equal to twice the latitude of the place. Substituting the observed values, we have:

$$\frac{66^\circ 48' + 20^\circ 23'}{2} = 43^\circ 36'$$

as the latitude of the house on Brookside Farm. Since it stands about two miles southwest of Dartmouth College Observatory, which is in latitude $43^\circ 42'$, the error in observing is about 0.1 of a degree.

117. Inclination of the ecliptic. — From the zenith distances at the solstices an approximate value of the inclination of the ecliptic may be obtained. The measure of this angle (Fig. 14) is EH'' , or its equal, EH' , and $2 EH''$ is the difference between the known zenith distances ZH' and ZH'' . Therefore half the difference of the zenith distances is equal to the angle which the ecliptic makes with the celestial equator, and from the zenith distances given in the preceding section we find the numerical value:

$$\frac{66^\circ 48' - 20^\circ 23'}{2} = 23^\circ 12'.$$

118. Retardation of sunset. — The time taken for the sun to set should theoretically be longer in some months than in others; for if its daily path is more inclined than usual to the horizon, it has a longer distance to traverse between the disappearance of the two limbs than when the path is more nearly vertical.

In mean northern latitudes the sun's diurnal path is most oblique at the time of the summer solstice, and so about that

time we should expect to find the greatest retardation. On the other hand, the path is most nearly vertical in March and October, and in these months the times of sunset should be shortest.

In spite of large accidental errors, the means given in the following table show a fair agreement between theory and observation. Irradiation doubtless accounts for the fact that the mean of the observed values is in each case larger than the corresponding mean derived by calculation.

TABLE IX.—DURATION OF SUNSET, NORTHAMPTON, MASS.

| DATE. | PLACE. | INTERVAL. | | OBSERVER. |
|---------|-----------------|--------------------------------|--------------------------------|-----------|
| | | OBSERVED. | COMPUTED. | |
| 1896 | | | | |
| Feb. 25 | 84 Elm St. | 2 ^m 55 ^s | 2 ^m 59 ^s | A. E. T. |
| Mar. 5 | Back Campus | 3 30 | | A. E. T. |
| Mar. 5 | Observatory | 2 44 | 2 56 | W. A. W. |
| Mar. 13 | Observatory | 3 7 | | F. H. D. |
| Mar. 13 | Observatory | 3 7 | 2 54 | W. A. W. |
| | | Mean, 3 6 | 2 56 | |
| June 4 | College Tower | 3 28 | 3 21 | M. T. B. |
| July 1 | Back Campus | [2 22]* | | A. E. T. |
| July 16 | Round Hill | 3 25 | 3 16 | A. E. T. |
| July 17 | Crescent St. | 3 20 | 3 17 | A. E. T. |
| | | Mean, 3 24 | 3 18 | |
| Oct. 19 | Washington Ave. | 2 57 | 2 59 | A. E. T. |
| Oct. 24 | Vernon St. | 3 9 | 3 2 | E. I. M. |
| Oct. 27 | Round Hill | 3 20 | 3 3 | H. W. B. |
| Oct. 31 | North Elm St. | 2 55 | 3 5 | A. E. T. |
| | | Mean, 3 5 | 3 2 | |

The computed intervals given in the table were obtained by taking the difference between the hour-angles of the sun at the times when the lower and upper limbs disappeared. The zenith

* Serious interference by trees.

distances required in computing are the angles between the zenith and the sun's centre when each limb is on the horizon. For the upper limb we have the common expression at sunset $\zeta = 90^\circ + r + s$ (§ 40). In the numerical calculation the sun's semi-diameter s was taken to the nearest tenth of a minute on the particular day; and r , the refraction at the horizon, was assumed to be $36'.5$ (Chauvenet, Table I). The same value of ζ was used for the lower limb, except that s was taken with the negative sign.

119. Effect of refraction shown by the sun-dial. — As long ago as the time of Tycho Brahe, it was noticed that the shadow on the sun-dial was retarded near the time of sunset; and this retardation was correctly referred to refraction. The connection is obvious, for the motion of the shadow is due to the diurnal motion of the sun; and refraction by impeding this motion near the western horizon causes a lagging of the shadow. To make a practical test, a good horizon is essential, and some pains must be taken in adjusting the dial.

OBSERVATION. — Smith College Tower, Friday, March 25, 1898. The sun-dial described in Section 17 was placed on a heavy stand on top of the tower, so as to command an unobstructed view of the western hills. The watch time of apparent noon was determined to the nearest second, and the dial moved and style shifted so that the shadow fell as nearly central as possible along the whole length of the noon line at the instant of noon. It took, however, an appreciable amount of time to make these adjustments, and an hour and a half later, as the dial appeared to be gaining about 20^s an hour, it was moved slightly to the east at the north side. No changes were made between $2^h 10^m$ and $5^h 55^m$ P.M.

During three hours, beginning with $2^h 15^m$, the dial and watch were read at intervals of fifteen minutes or oftener, and after that, readings were made every five minutes till $5^h 55^m$ P.M. Although

that time was fourteen minutes earlier than theoretical sunset, no further observations could be made satisfactorily, as haze rendered the shadow indistinct.

Taking into account the different readings, we find that the sun-dial gained on an average about 9^s an hour during the 3 hours, but in the last 45 minutes it lost at the mean rate of 6^s in 5 minutes, losing in all 50^s between $5^h 10^m$ and $5^h 55^m$. It is worthy of note, however, that the change at first was so gradual that nearly all the loss, that is 45^s , came in the last 20 minutes. The theoretical loss for the 45 minutes computed for the given time and place is 61^s .

120. Length of twilight.—The varying length of twilight* and retardation of sunset (§ 118) depend upon the same principle. According to the common definition, twilight lasts until the sun is 18° below the horizon, measured on a vertical circle, and the more obliquely it moves with regard to the horizon the longer it will take to reach this point. In mean northern latitudes, then, twilight should be longest in June and shortest in March and October.

Although the definition of twilight is based on observation, a close agreement is not to be expected between the observed and computed length on any single evening. As we have seen in Section 109, the time of actual and theoretical sunset may differ largely. Moreover, artificial lights, the state of the atmosphere, and the condition of the observer's eyes have much to do in fixing the end of twilight.

OBSERVATION 1.—S. C. O., Saturday, July 11, 1896. The time of sunset was determined from the roof of the observatory, but trees forming the northwest horizon line were so near that a few feet made a difference in the sun's apparent position. At $7^h 10^m$ the sun passed below the tree-tops, but it could still be

* For some interesting numerical calculations about twilight see O. E. Harmon's articles in Vol. IV of *Popular Astronomy*.

seen through the trees till 7^h 13^m. During the two hours following, the Milky Way was noted from time to time, and when it seemed as bright as at any hour of the night the watch time was 9^h 10^m. If we call 7^h 13^m the time of sunset, the observed length of twilight was 1^h 57^m. The computed length is 2^h 8^m.

To avoid any bias in favor of a long twilight, care was taken between the two records not to know the time within half an hour.

On the evening of July 1, the appearance of sixth magnitude stars in Ursa Minor was taken by another observer to fix the end of twilight. Its length thus determined was 1^h 54^m, but calculation gives 2^h 12^m. (A. E. T.)

OBSERVATION 2.—Back Campus, Friday, Oct. 9, 1896. Sunset was watched through a break in the trees where a low even line of distant hills marked the horizon. Behind this line the upper limb of the sun disappeared at 5^h 7^m. At 6^h 32^m sixth magnitude stars in Ursa Minor became visible, and the Milky Way appeared distinct at 6^h 34^m. Twelve minutes later, however, it was clearer and could be followed farther down toward the horizon. (A. E. T.)

If we take the mean of these three times as the final determination, twilight ended at 6^h 37^m, having lasted 1^h 30^m. The theoretical duration was 1^h 33^m.

121. Twilight bow and earth's shadow.—The direction of shadows when the sun is setting indicates what part of the horizon to watch for the first appearance of the twilight bow in the east. A clear horizon is indispensable.

OBSERVATION.—Smith College Tower, 7^h P.M., Thursday, June 4, 1896. The pink glow visible on the eastern sky lay near the horizon and extended about 180°. It seemed more like a band than a bow of light. Below it was seen what appeared to be the earth's shadow. It filled the space between the twilight bow and the horizon line, and was of a dull blue color. (M. T. B.)

122. Zodiacal light. — February and March are favorable months for watching the zodiacal light in the west, provided the view is unobstructed and the sky free from the effect of artificial lights.

OBSERVATION. — S. C. O., 7^h 30^m P.M., Thursday, March 5, 1896. The zodiacal light appeared to rise from the western horizon and extended to the Pleiades, about halfway from horizon to zenith. It was conical in shape, and the light was like the Milky Way, only fainter. (C. F. H.)

Students who desire to make a critical study of the zodiacal light will find full and careful directions in Appendix B, which has been prepared for this manual by Professor Arthur Searle of Harvard College Observatory.

123. Partial eclipse of July 29, 1897. — 84 Elm Street, Northampton, Mass. The morning of July 29, 1897, was very cloudy here, but at nine o'clock, about ten minutes after the almanac time for the beginning of the eclipse, the sun appeared to view with a "bite" taken out of its western limb. The arc of the eclipsed section was estimated to be less than a fifth of the circumference, and the depth was small in comparison. Ten minutes later the eclipse seemed to extend over one fourth of the circumference, and about 9^h 30^m it had reached inward one fourth of the sun's diameter. Clouds made further observations impossible. (A. E. T.)

CHAPTER VI.

THE MOON.

IN naked-eye study of the heavens observations of the sun and moon should be carried on together, as they tend to supplement each other. Thus, from the sun we obtain most readily a clear idea of the diurnal path of a heavenly body; and the moon's course during a month gives the best illustration of a path traced on the sphere among the stars.

A comparison of the diurnal paths of the two bodies shows the effect of slow and rapid changes in declination.

Measures of the sun's altitude and azimuth help to locate the ecliptic in the daytime; and at night its approximate place is fixed in like manner by the moon.

The questions which follow are designed, like those in Chapter V, to be answered from observation, or by data obtained from observation. The time employed is not so uniformly eastern standard time as in the preceding chapters; but care has been taken to indicate in the text when the astronomical day and local time are required.

QUESTIONS.

124. Rising and setting.

1. Where does the moon rise on two or three evenings during the week of full moon?
2. Does the moon rise at the same time when watched from the ground floor and the roof of the same building?
3. How nearly do observed times of rising agree with almanac times?
4. When the moon is nearly full in September or October, how do the times of rising on successive evenings compare with one another?

5. How are shadows near sunset a guide in fixing in advance the place where the full moon rises?

6. When the moon is full on any evening, how does its time of rising compare with the time of sunset?

7. How does its amplitude at rising compare with that of the sun at setting?

8. On two or three evenings within ten days after new moon, at what times and at what points on the horizon does the moon set?

9. How do these times agree with the almanac times?

10. On a given evening does the moon rise north or south of the sunrise point?

11. On a given evening does the moon set north or south of the sunset point?

12. How do times of rising and setting on any date compare with those of the sun?

125. Crescent moon.

1. Where is the old moon last visible?

2. How short then is the interval before new moon?

3. After new moon where does the moon appear?

4. How soon after new moon is the moon visible?

5. At the time of any particular observation what angle does the line joining the cusps of the moon make with the horizon?

6. What is the date of the observation when the line joining the cusps is most nearly perpendicular to the horizon?

7. On what date is this line found to be most nearly parallel to the horizon?

8. What angle does the line joining the centres of the sun and moon make with the horizon on a given date?

9. If the crescent moon is in the west, in what direction do the horns point?

10. If the crescent moon is in the east, in what direction do the horns point?

11. How does the moon grow from a tiny crescent to half full? that is, does the light increase uniformly in all parts of the crescent?

126. Altitude and azimuth.

1. What is the altitude and azimuth of the moon at a given hour and minute?
2. In how short a time is a change detected in these coördinates?
3. What changes are found in an hour?
4. During a particular day, between what limits approximately do altitude and azimuth vary?
5. How accurately are these coördinates estimated from the shadows of trees or buildings?
6. What is the difference in altitude and azimuth between the moon and a neighboring star or planet?
7. How does the meridian altitude of the moon compare with that of the sun taken on the preceding or following day?

127. Right ascension and declination; latitude and longitude.

1. If distances are estimated directly from the celestial equator and vernal equinox, what value is found for the moon's right ascension and what for its declination?
2. How accurately are these coördinates obtained by mapping the moon with the neighboring stars?
3. Is any change detected in their values in a single night? From night to night?
4. At a given hour how many degrees is the moon above or below the ecliptic?
5. If measures are made along the ecliptic, how many degrees is it east or west of the vernal equinox?

128. Diurnal path.

1. When referred to the horizon, is the moon moving east or west?
2. How many hours intervene between southing and setting?
3. Are there days when the moon takes more than twelve hours to traverse the visible part of its diurnal path?
4. How does a change in the moon's declination affect its diurnal path?
5. During what part of a given lunar month does the moon "run high"? During what part does it "run low"?

6. What are the highest and lowest meridian altitudes noted during a lunar month?

7. What are the largest and smallest amplitudes obtained in a month?

8. Is the diurnal path fixed by observation a small or a great circle?

9. What is the moon's hourly rate of motion in this path?

10. How can you dispel the illusion that the moon is "scudding" through the clouds?

11. If the diurnal paths of the sun and moon are fixed for a given day, how do they compare?

12. Is the relative position of these paths the same in different months? On different dates in the same month?

129. Path among the stars.

1. In what direction does the moon move among the stars?

2. What is the hourly rate of this motion?

3. On two or three different dates how does the moon's position among the stars compare with the position given in the Old Farmer's Almanac?

4. As far as it can be followed in one lunar month, through what constellations does the moon pass?

5. Does it pass through the same constellations in different months?

6. During two different months in the fall and winter, how near does the moon approach α Capricorni, α Aquarii, α Arietis, and the Pleiades?

7. During two months in spring and summer, how near does the moon approach β Geminorum, α Leonis, and α Virginis?

8. What is the smallest distance observed between the moon and a planet or star?

130. Periods.

1. What is the interval in days and hours, determined by observation, from first quarter to first quarter, or from full moon to full moon?

2. How nearly do determinations agree when made independently at different times?

3. How many days and hours elapse from the time when the moon is near a star until it is near the same star again?

131. Time.

1. How accurately can you determine time from an altitude of the moon? From an altitude and azimuth?

2. How accurately is the error of a watch found from a meridian transit of the moon?

132. Face appearance.

1. What is the color of the moon at any given time? that is, is it silvery white, pale yellow, deep yellow, or reddish yellow?

2. Is the color different on different nights? Are variations noted in one night?

3. How are the dark markings located on the disk? What proportional part do they occupy?

4. Are the markings all equally dark?

5. Do they change their position with regard to the limb, to the terminator, or to one another?

6. How does the moon, seen when the sun is shining, differ from the moon seen at night?

7. What points of difference are noted between a small white cloud and the moon observed in broad daylight?

8. How do you describe the appearance known as the "old moon in the new moon's arms"?

9. Do the dark and illuminated parts seem to belong to the same circle?

10. If not, which part belongs to the larger circle?

11. On any given evening what proportion of the disk is visible?

12. Is the bounding line between the light and dark portions smooth or broken?

13. At the time of observation does the terminator form a concave or convex boundary for the bright part of the moon?

14. Having watched the moon from week to week, and month to month, can you lay down a general rule for the form of the terminator?

15. When, if ever, does the terminator appear to be a straight line?
16. Just before full moon, is the eastern or western limb defective?
17. Does the moon appear full either on the night before or the night after it is set down as full in the almanac?
18. Does the moon appear full to the naked eye during an evening of three or four hours?
19. Seen with opera-glasses does the moon appear full during a period of three or four hours?
20. Which limb becomes defective just after full moon?
21. Under what circumstances have you seen the vertical diameter of the full moon shorter than the horizontal diameter?
22. Does the moon look larger when near the horizon or when near the zenith?
23. How do two views of the moon differ if obtained at about the same time with the naked eye and with the transit tube?
24. How does the full moon compare in size with the sun?

133. An eclipse.

1. Before an eclipse begins, is any decrease in brightness noted on any part of the moon's limb?
2. At what part of the limb does the shadow first appear?
3. At what minute are you sure that the eclipse has begun?
4. What is the color of the shadow when first seen upon the moon?
5. Do the color and darkness of the shadow remain the same throughout the eclipse?
6. About an hour after the eclipse has begun, how much does the light of the moon seem to be diminished?
7. At that time what part of the disk is obscured?
8. Is the bounding line sharp and distinct to the naked eye?
9. How does it appear in an opera-glass?
10. Is the brightness or color of the uneclipsed moon affected by the shadow?
11. Is it possible to distinguish any objects within the shadow?
12. Can you tell with the naked eye when the edge of the shadow reaches any given object on the moon?

13. How near the eclipsed moon can you see a star? What is its magnitude?

14. Does any star disappear behind the moon or come out from under it during the eclipse?

15. If the eclipse is partial, what is its magnitude when greatest? At what time does this phase occur?

16. If the eclipse is total, when does totality begin? When end?

17. Is the moon visible when totally eclipsed? If so, what is its color?

18. How does the sky at the time of totality compare with the sky on a clear moonless night?

19. At what time during the eclipse do faint stars begin to appear?

20. When does the Milky Way regain its usual brightness?

21. When nearly under the shadow or just coming out, what are the forms of the dark and illuminated parts of the moon?

22. At what minute does the eclipse end?

23. At what part of the limb is the last contact?

SUGGESTIONS AND ILLUSTRATIONS.

134. Diurnal path from observation. — On any night when the moon is full or nearly full, its course can be followed across the sky from the eastern to the western horizon. If under these conditions its altitude and azimuth are measured at intervals of about an hour, we have sufficient data for plotting the diurnal path. It is only necessary to observe from the time of rising to meridian passage, or from meridian passage to setting, if we assume that the moon like the sun describes a path which is practically symmetrical with regard to the meridian (§ 111).

At Northampton, Mass., Saturday, July 25, 1896, the night after the moon was full, twelve measures of its altitude and azimuth were made with the Circles. For the purpose of comparing the diurnal paths of different heavenly bodies on this date, Mars and Fomalhaut were observed at regular intervals

from the time of rising till the morning twilight rendered them invisible. The path of the sun was also fixed by noting its southing and setting July 25 and its rising on July 26. These observations are included in the following table.

TABLE X. — COÖRDINATES OF HEAVENLY BODIES. JULY 25 AND 26, 1896, NORTHAMPTON, MASS.

| TIME. | ALTITUDE. | AZIMUTH. | REMARKS. |
|-----------------------------------|-----------|----------|----------------------------|
| | MOON. | | |
| July 25, P.M. | | | |
| [7 ^h 54 ^m] | | [290°] | Moon rising. |
| 8 55 | 9°.5 | 301.6 | One measure through trees. |
| 9 10 | 11.3 | 304.2 | |
| 9 37 | 15.3 | 308.0 | Moon clear of trees. |
| 10 14 | 20.8 | 316.0 | |
| 11 13 | 27.5 | 328.9 | |
| July 26, A.M. | | | |
| 0 12 | 31.9 | 344.0 | |
| 1 13 | 33.7 | | Moon southing. |
| 2 12 | 32.1 | 17.8 | |
| 3 12 | 27.8 | 32.3 | |
| 4 8 | 21.9 | 45.9 | |
| 5 10 | 12.7 | 59.0 | |
| 5 52 | 6.6 | 65.8 | |
| [6 32] | | [73] | Moon setting. |

With the exception of the values in brackets, each time given in the table is the mean of the times corresponding to the different measures for one position, and every altitude and azimuth is the mean of three or more measures, unless the contrary is stated in the remarks.

The bracketed values for azimuth were obtained by carrying the positions of the bodies forward or backward from those already determined. Thus, owing to obstructions on the east (§ 107) the moon was not visible from the upper meridian stone on the south till about an hour after its theoretical time of rising,

and it was still forty minutes later before the view was unobstructed by trees. Careful note was then taken of the particular spray of foliage from which the moon emerged into full view, and half an hour later an imaginary line drawn through this

TABLE X (Continued).

| TIME. | ALTITUDE. | AZIMUTH. | REMARKS. |
|--------------------|------------|----------|----------------------------|
| | FOMALHAUT. | | |
| July 26, A.M. | | [322°] | Star rising. |
| 0h 9 ^m | 12°.6 | 330 .4 | Time for only one measure. |
| 0 20 | 13 .6 | 332 .1 | |
| 1 22 | 17 .5 | 346 .1 | |
| 2 26 | 18 .6 | | Star southing. |
| 3 24 | 17 .4 | 13 .1 | |
| 4 12 | 13 .0 | 29 .0 | (A. E. T.) |
| | MARS. | | |
| | | [249°] | Mars rising. |
| 0 28 | 9°.0 | 255 .8 | |
| 2 32 | 34 .0 | 279 .5 | |
| 3 32 | 44 .2 | 289 .9 | |
| 4 19 | 50 .5 | 305 .8 | Two measures, (A. E. T.). |
| | SUN. | | |
| July 25. | | | |
| 12h 6 ^m | 67 .6 | | Sun southing. |
| 6 58 | | 113 .5 | Sun setting. |
| July 26. | | | |
| | | [240] | Sun rising. |

point and the moon's actual position met the plane of the horizon on the north side of a tree in the foreground. A similar estimate made about eleven o'clock fixed the place of moonrise south of the same tree, and the mean of the azimuths of these two points is the value entered in the table.

Although it was possible to follow the moon much nearer

to the western than the eastern horizon, a like method was employed in fixing the azimuth at setting.

The hour-angles and times corresponding to these estimated positions were derived by calculation, as shown in the following section.

135. Times of rising and setting from observation. — The time of moonrise depends upon the hour-angle, which may be obtained approximately from an observed azimuth (§ 108). Thus, if we take the moon's azimuth as 290° when rising at Northampton, Mass., July 25, 1896 (Table X), the corresponding hour-angle may be computed as follows (§ 40 (4)):

| | | |
|---|---|---|
| $\log \cos \phi = 9.8690$ | | $\log \sin \phi = 9.8280$ |
| $\log \cos A = \underline{9.5341}$ | $\log \sin A = 9.9730$ | $\log \cos A = 9.5341$ |
| $\log \sin \delta = \underline{9.4031}$ | $\log \cos \delta = \underline{9.9855}$ | $\log \sec \delta = \underline{0.0145}$ |
| $\delta = -14^\circ.7$ | $\log \sin t = \underline{9.9875}$ | $\log \cos t = \underline{9.3766}$ |
| $t = -76.3 = -5^h 5^m$ | | |

In like manner the hour-angle at the setting of the moon on the same date is found to be $5^h 14^m$. It remains, therefore, to reduce these hour-angles to eastern standard time.

When the hour-angle of a heavenly body is known, sidereal time is found by adding to this angle the body's right ascension at the instant when the hour-angle was determined (§ 39). But this time is the unknown quantity required, so the first step is to obtain an approximate value for the required time.

For the preliminary data, we refer as usual to the Ephemeris, but as the astronomical day is employed there, we naturally carry on the reduction in local time, at least until the final step is reached (§ 46).

From p. IV of the Ephemeris for July, 1896, we find $13^h 9^m.1$ as the mean time of the moon's meridian passage at Greenwich on the 25th. Making the first approximation to the nearest hour only, we take 13^h as the local time of transit at

Northampton (§ 38); and since the moon's hour-angle when rising there was -5^h nearly, 8 P.M. may be assumed as the approximate time of moonrise at Northampton.

Calling 5^h the difference in longitude between Northampton and Greenwich (Appendix E), the corresponding Greenwich time is 13^h . With this time as argument, we turn to p. XI of the July Ephemeris, and find that the moon's right ascension was $21^h 26^m$. This right ascension combined with the east hour-angle, $5^h 5^m$, gives the sidereal time of rising $16^h 21^m$, and the final reduction to mean time (§ 53) is made as follows:

| | |
|---|---|
| $\odot = 16^h 21^m$ | $\odot = 16^h 21^m$ |
| $V_0 = \frac{8 \ 15}{}$ | $V_0' = 15 \ 47$ |
| $\odot - V_0 = \frac{8 \ 6}{}$ | Corr. for $\odot = -3$ |
| Corr. for $\odot - V_0 = -1$ | Corr. for $\lambda = \frac{-1}{}$ |
| Corr. for $\lambda = \frac{-1}{}$ | $\frac{8 \ 4}{}$ |

If now to $8^h 4^m$, the mean local time of moonrise, we add the difference in longitude, $4^h 51^m$, the sum, $12^h 55^m$, gives a more exact Greenwich time.

Proceeding in like manner with the second approximation, the right ascension derived is $21^h 25^m.6$, the sidereal time $16^h 20^m.6$, and the local mean time of rising $8^h 3^m.7$ P.M. Since this result differs only $0^m.3$ from that found at first, no further approximation is needed, and the corresponding standard time, $7^h 54^m$, is therefore the value entered in brackets in Table X.

In like manner we find the standard time when the moon set, on the morning of July 26, to be $6^h 32^m$; and the difference between the two, $10^h 38^m$, is the interval according to observation during which the moon was above the horizon on the given date.

When the moon's hour-angle is known, it is often sufficiently accurate to determine the corresponding mean time directly

from meridian passage. Since any local time of transit can be derived from that at Washington, let us begin by finding the approximate time of transit for the particular meridian on which the moon happens to be when rising at the given place. This time can then be reduced to that of the required meridian. For example, on July 25, 1896, the moon crossed the Washington meridian at $13^{\text{h}} 18^{\text{m}}.8$, but when it rose that evening at Northampton with an hour-angle $-5^{\text{h}} 5^{\text{m}}$, it was practically on a meridian $5^{\text{h}} 5^{\text{m}}$ east of that place, or $5^{\text{h}} 23^{\text{m}}$ ($5^{\text{h}}.38$) east of Washington, as Northampton is 18^{m} farther east than Washington (Appendix E).

Now as a difference of one hour in longitude, according to the Ephemeris, causes a difference of $1^{\text{m}}.87$ in the local time of transit, the time of transit at the eastern meridian should be $13^{\text{h}} 18^{\text{m}}.8 - (1^{\text{m}}.87 \times 5.38)$, or $13^{\text{h}} 8^{\text{m}}.7$. But this is the time at the eastern meridian when the moon was rising at Northampton, and as the difference between the meridians considered is $5^{\text{h}} 5^{\text{m}}$, we conclude that the local time of moonrise at the latter place was $8^{\text{h}} 3^{\text{m}}.7$ P.M., a result which agrees with that found by the rigorous method first given.

136. Theoretical time of moonrise. — The hour-angle of the moon at rising, whence the corresponding time is derived, may be computed from the same formula as that employed for the sun (§ 108). If, however, accurate results are desired, it is necessary to take into account the effect of parallax on zenith distance. An illustration of this method may be found in Section 145. But when observing is carried on at a fixed station it is more convenient to calculate a table once for all, by means of which the time when the moon rises or sets on any date can readily be determined.

Appendix D contains a section of such a table computed for Northampton, Mass., according to the method described and illustrated by Professor Frisby (Appendix C). The arguments

required for deriving hour-angles from this table are the moon's declination and parallax at the unknown time of rising. We must, therefore, proceed by approximations, employing the astronomical day and local time as in the examples just given.

EXAMPLE. — Obtain from Appendix D a theoretical check for the time of moonrise July 25, 1896, Northampton, Mass.

In order to obtain a first approximation for the time of moonrise, we begin by finding the time of local transit, as in the preceding section. Thus we have:

| | |
|--|---|
| Transit of moon at Washington | = 13 ^h 18 ^m 47 ^s |
| “Diff. for 1 Hour” = 1 ^m .87. ∴ corr. = 1 ^m .87 × 0.29 = | 33 |
| Northampton time of meridian transit | = 13 18 14 |

The Greenwich time which corresponds to the Northampton transit is, therefore, 18^h 9^m. Assuming that the moon rose 6^h before its meridian passage, we may take 12^h as the argument for the Greenwich Ephemeris. Hence, from p. IV, for July, parallax is found to be 56', and declination taken from p. XI is -16°.

With these first approximations for π and δ we enter the table in Appendix D and read directly the hour-angle 4^h 57^m. But before making use of this hour-angle in deriving the time of moonrise, let us correct it from p. IV of the Ephemeris, and thus take account of the moon's motion in right ascension during the interval between rising and meridian passage. Since the “Diff. for 1 Hour” is 1^m.90, the correction for 5^h is about 10^m, making the corrected hour-angle 5^h 7^m. But the Greenwich time of transit at Northampton is 18^h 9^m, and so the difference between the two, 13^h 2^m, is the approximate Greenwich time of local moonrise.

Employing now 13^h 2^m as a more accurate argument, we turn to pp. IV and XI of the Ephemeris and take out $\pi = 55'.7$ and $\delta = -15^\circ 41'.0$. The “Diff. for 1 Hour,” 1^m.89, is taken

also from p. IV, but for the time midway between rising and southing, that is, for $15^{\text{h}} 36^{\text{m}}$.

With these values of π and δ the hour-angle obtained from the table is $4^{\text{h}} 58^{\text{m}} 45^{\text{s}}$, which corrected for hourly motion ($1^{\text{m}}.89 \times 4.98$) becomes $5^{\text{h}} 8^{\text{m}} 10^{\text{s}}$. As the first approximation was $5^{\text{h}} 7^{\text{m}}$, the second gives a value about a minute larger. A third approximation computed in the same manner makes the hour-angle $5^{\text{h}} 8^{\text{m}} 9^{\text{s}}$, and since the difference between the last two is only 1^{s} the third value is considered final.

The different steps already described and the final reduction to standard time are arranged in tabular form as follows:

| | |
|--|--|
| Hour-angle from table ($\delta = -16^{\circ}$, $\pi = 56'$) | = $4^{\text{h}} 57^{\text{m}}$ |
| Correction, p. IV, for July, $1^{\text{m}}.90 \times 5.0$ | = $\frac{10}{}$ |
| Corrected hour-angle | = $\frac{5}{} \frac{7}{}$ |
| Greenwich time of local transit | = $\frac{18}{} \frac{9}{}$ |
| Greenwich time of local rising | = $\frac{13}{} \frac{2}{}$ |
| | |
| Hour-angle from table ($\delta = -15^{\circ} 41'.0$, $\pi = 55'.7$) | = $4 \ 58 \ 45^{\text{s}}$ |
| Correction, p. IV, for July, $1^{\text{m}}.89 \times 4.98$ | = $\frac{9 \ 25}{}$ |
| Corrected hour-angle | = $\frac{5 \ 8 \ 10}{}$ |
| Greenwich time of local transit | = $\frac{18 \ 8 \ 47}{}$ |
| Greenwich time of local rising | = $\frac{13 \ 0 \ 37}{}$ |
| | |
| Corrected hour-angle, third approximation | = $5 \ 8 \ 9$ |
| Greenwich time of local transit | = $\frac{18 \ 8 \ 47}{}$ |
| Greenwich time of local rising | = $\frac{13 \ 0 \ 38}{}$ |
| Eastern standard time of local rising | = $8 \ 0 \ 38$ |

According to the method just illustrated, we find also from Appendix D that the setting of the moon on the morning of July 26 came at $6^{\text{h}} 26^{\text{m}}$. A comparison of these computed times with those in Table X brings out the somewhat surprising fact that the moon was 13^{m} longer above the horizon according to observation than according to theory. Still, as accidental errors seem to outweigh all others in estimat-

ing azimuth (§§ 139, 140), the times derived are about as likely to make the period above the horizon too long as too short.

After practice has given skill in using a table like that in Appendix D, the first approximation is often sufficiently accurate; and a third is rarely required.

137. Hourly rate of apparent motion.—A fixed point on the celestial sphere appears to pass from one meridian to another at the rate of 15° in a sidereal hour. If, then, the moon had only the westward motion given it by the turning of the earth on its axis, it would move at the same rate as the fixed point; but since in addition it has an eastward motion of its own, the apparent motion should practically equal 15° an hour, diminished by the hourly motion in right ascension. In order to find the apparent motion from observation, we obtain the intercept on the equator between two positions of the moon, and divide it by the number of hours between the observations.

EXAMPLE.—From data given in Table X find the hourly rate of the moon's apparent motion July 26, 1896.

In following the diurnal motion of the moon the distance between two positions measured on the celestial equator is the same as the difference in the corresponding hour-angles, and so our first step is to derive these angles from observation.

The accurate determination of the moon's hour-angle requires corrections for parallax and refraction (§ 145), but both may be omitted in the given example as the difference between two hour-angles rather than the absolute value of either is required. If one correction is omitted, the other should be, as they tend to counteract each other.

Turning to Table X, we find that the first observation after the moon's meridian passage was taken at $2^{\text{h}} 12^{\text{m}}$ A.M., giving an altitude $32^\circ.1$ and azimuth $17^\circ.8$. With these coördinates we proceed then according to Formula (5), Section 40.

| | | | | |
|---------------------|------------------------|----------------------------|------------|--|
| | | $\log \tan \zeta = 0.2025$ | | |
| $\phi = 42^\circ.3$ | $\log \cos A = 9.9787$ | $\log \tan A$ | $= 9.5066$ | |
| $M = 56.6$ | $\log \tan M = 0.1812$ | $\log \sin M$ | $= 9.9216$ | |
| $\phi - M = -14.3$ | | $\log \sec (\phi - M)$ | $= 0.0137$ | |
| $t = 15.5$ | | $\log \tan t$ | $= 9.4419$ | |

In like manner the hour-angle, $68^\circ.4$, is obtained from the coördinates $6^\circ.6$ and $65^\circ.8$, measured at $5^{\text{h}} 52^{\text{m}}$ A.M., July 26. The difference between the two, $52^\circ.9$, divided by 3.67, the interval in hours between the observations, gives $14^\circ.41$ as the hourly rate of the moon's apparent motion. The moon's own motion in right ascension in an hour deduced from these observations is

$$15^\circ.0 - 14^\circ.4, \text{ or } 0^\circ.6.$$

As 15° is the apparent motion of the celestial sphere in a sidereal hour, the moon's observed rate should be taken for the same hour; that is, strict accuracy would require us to divide $52^\circ.9$ by 3.68, the sidereal interval corresponding to $3^{\text{h}}.67$. In this example, however, the correction does not change the result, $0^\circ.6$, obtained above.

To obtain a check from the Ephemeris for this value we find how much the moon's right ascension increased between the times employed, and divide as above, by the number of hours intervening. Thus we have:

$$21^{\text{h}} 45^{\text{m}}.2 - 21^{\text{h}} 38^{\text{m}}.1 = 7^{\text{m}}.1 = 1^\circ.78,$$

and

$$\frac{1^\circ.78}{3.68} = 0^\circ.48.$$

Although the moon's motion in right ascension constitutes a large part of its proper motion, a part is of course due to declination. Data for determining the entire proper motion during an interval of several hours may be found in Section 144. Reference to Fig. 16 given there shows that the moon's motion in degrees between positions 1 and 2 can be obtained from the

star-line, 31α , in Leo (§ 6). This number of degrees divided by the number of hours required to pass from 1 to 2 gives the moon's hourly rate of proper motion. A theoretical check is derived by computing one side of a spherical triangle, as in obtaining the distance between two heavenly bodies (§ 72).

138. Graphic representation of diurnal paths. — The coördinates of the different bodies in Table X are plotted in Fig. 15, as described in Section 111.

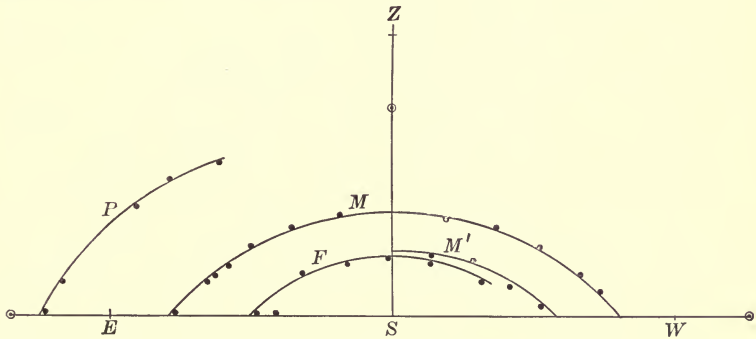

FIG. 15. — Diurnal Paths of Moon, Planet, and Star.

Here, as in Fig. 13, Z is the zenith point, and E , S , and W the cardinal points east, south, and west. The complete curve marked M gives the moon's path on the night of July 25 and 26, 1896. The line below and to the right, M' , shows its path during the second half of the diurnal course on the 17th of the following August, when its declination was only 2° larger than that of Fomalhaut. The path of the star itself, designated by F , was determined as usual on July 26, except that the first point of the curve on the left was found by taking the mean of the azimuths estimated on that night and on three other nights in August and September (§ 166). The one azimuth given in Table X places the rising point at the dot farther inward on the line WE .

That part of Mars's path which was traced above the horizon before daylight (§ 134) is marked *P*, and the three positions of the sun are fixed by dots enclosed in circles.

When we try to use the celestial globe in representing the diurnal path of the moon, we find a disturbing factor in the moon's own motion among the stars. For the sun this motion is very small, but for the moon it is likely to amount to several degrees between rising and setting. Perhaps the best plan is to orient the globe for the time of the moon's meridian passage, secure it firmly in that position, and then plot the places of the moon for the different observations. The lunar path thus located by means of the altitudes and azimuths given in Table X is seen to be approximately a small circle, slightly inclined to the parallels of declination. The rising point is found near the parallel of 15° south declination, while the setting point comes on a parallel about 3° farther north, a result by no means surprising, since according to the Ephemeris the declination of the moon increased more than 2° between rising and setting.

139. The hunter's moon. — The marked prominence of the harvest and the hunter's moon is a characteristic of high northern latitudes, but most observers will find that when the moon is nearly full in either month there is a decided shortening of the interval between the times of moonrise on successive nights.

In October, 1896, at Northampton, Mass., the weather permitted observations on the 19th, two days before full moon, and on the 22d and 24th following. The azimuth of the moon at rising was estimated as usual (§ 134) and the corresponding time deduced by calculation (§ 135). The results obtained and their checks are given in the table on the opposite page.

By comparing these dates and times, we see that the average daily retardation of moonrise for two days before and one day after full moon was 22^m ; and for the whole interval of five days, 26^m , which is only about half the average retardation of

TABLE XI. — MOONRISE IN OCTOBER, 1896, NORTHAMPTON, MASS.

| DATE. | AZIMUTH. | TIME. | |
|---------|----------|------------------------------------|-------------------------------------|
| | | FROM AZIMUTH. | FROM APPENDIX D. |
| Oct. 19 | 264° | 4 ^h 1 ^m P.M. | 3 ^h 56 ^m P.M. |
| “ 22 | 244 | 5 8 “ | 5 3 “ |
| “ 24 | 233 | 6 9 “ | 6 12 “ |

51^m (Young, Art. 236, E. Art. 143). The 22^m agrees exactly with the value obtained from the computed times in column four; and 27^m, the theoretical average for the five days, is only one minute larger than that derived from observation. The rude method, however, of obtaining the time of moonrise leads us to attribute the close agreement, in part at least, to accident.

140. Moonrise in April. — The full moons of March and April, being especially retarded in rising on successive nights, are those which present the most noticeable contrast to the harvest and hunter's moons.

In order to see how large a retardation could be deduced by the method of estimates employed in October, the moon was watched on the night of full moon in April and on the nights immediately before and after. The azimuth and time of rising obtained for each date as in the preceding section are given below.

TABLE XII. — MOONRISE IN APRIL, 1897, NORTHAMPTON, MASS.

| DATE. | AZIMUTH. | TIME FROM AZIMUTH. |
|----------|----------|------------------------------------|
| April 16 | 286° | 6 ^h 9 ^m P.M. |
| “ 17 | 294 | 7 32 “ |
| “ 18 | 296 | 8 39 “ |

Between April 16 and 17 we find that retardation was the same by observation and by theory, that is, $1^{\text{h}} 23^{\text{m}}$. But the average daily interval between moonrise for the two nights included was $1^{\text{h}} 15^{\text{m}}$ derived from the observed azimuth, while Appendix D gives $1^{\text{h}} 23^{\text{m}}$.

The results obtained in this and in the preceding section show how the difficulties of a poor observing station may be largely overcome by a method of estimates, supplemented by calculation. It is, however, much easier as well as more accurate to observe the rising of heavenly bodies directly from a good horizon line (§ 141).

141. Sunset and moonrise.—The path of the moon on the celestial sphere is always near the ecliptic (§ 81), and hence when the moon is full, that is, in longitude 180° from the sun, we should expect it to rise about the time when the sun sets. Theoretically considered, however, the times of moonrise and sunset should rarely, if ever, agree exactly; for to mention only one point, the moon seldom rises at any given place just at the instant when it is full.

OBSERVATION.—Clover Hill Farm, Lawrence, Kan., Saturday, Oct. 29, 1898. From the roof of the house a good horizon line is seen about three miles distant in both directions, east and west.

The mills in the town give a somewhat smoky appearance to the eastern horizon, but when the moon first came in sight over Mr. Plasket's orchard, less than a fourth of the disk was visible. The central standard time noted at the instant was $5^{\text{h}} 21^{\text{m}}.6$. A few minutes later, at $5^{\text{h}} 28^{\text{m}}.1$, the upper limb of the sun disappeared behind a clear horizon line. Thus, according to observation the moon rose $6^{\text{m}}.5$ before the sun set. (A. H. B.)

The results obtained from this observation and others of like character are included in the table on the opposite page.

In calculating the theoretical interval the centre of each body

TABLE XIII.—INTERVAL BETWEEN SUNSET AND MOONRISE.

| DATE. | PLACE. | TIME OF PHASE TO TIME OF RISING. | INTERVAL. | |
|--------------|--------------------|--|------------------|-------------------|
| | | | OBSERVED. | COMPUTED. |
| Apr. 16, '97 | Northampton, Mass. | — 7 ^h | — 6 ^m | — 13 ^m |
| Feb. 6, '98 | “ “ | + 4 | + 18 | + 14 |
| Oct. 29, '98 | Lawrence, Kan. | + 11 | — 6 | — 7 |

was employed. The sign + denotes that moonrise came after sunset, and — that it came before. The so-called observed intervals found at Northampton depend upon estimated azimuths (§ 139).

From the third column we see that on each date a number of hours intervened between the instant of the phase and the instant of rising, though the observations were carefully taken when the moon rose nearest the instant of full moon for the given month.

The few observations given are found to accord with the theoretical view that the full moon rises approximately, not exactly, at the time of sunset.

142. Direction of the moon's horns with regard to the horizon.

— From casual observation we know that the line joining the horns of the moon makes very different angles with the horizon at different times. The inclination at any particular time may be determined at least approximately by direct eye estimates, though doubtless preliminary practice is desirable.

OBSERVATION 1. — S. C. O., Friday, Feb. 25, 1898. On this evening the following device was employed to find the angle between the horizon and the line joining the horns of the moon.

The two forefingers were placed so as to form a rude quadrant, that of the right hand being parallel to the horizon. The

quadrant was divided by the middle finger of the left hand, and both hands were moved up and down till this finger seemed parallel to the line joining the horns of the moon. The lower angle of the quadrant between this finger and the one parallel to the horizon was called more than 30° and less than 45° at $7^h 15^m$ P.M. The mean of the two, 38° (§ 5), is the estimated inclination required. (A. E. T.)

OBSERVATION 2. — S. C. O., Thursday, Oct. 20, 1898. This evening when I looked at the moon about half after seven, the line joining the horns seemed to make an angle of 45° with the horizon. Just after making the estimate, I took three measures with the jointed rulers, holding them so that one ruler was parallel to the horizon, and the other passed through the horns of the moon. The mean angle obtained, 48° , corresponded to $7^h 42^m$ P.M. (K. H. L.)

These angles may be checked on the celestial globe, if we assume that the circles connecting the horns of the moon and the centres of the sun and moon make a right angle with each other (Proctor's "Moon," p. 89).

To effect this graphic construction, the places of the sun and moon at the time of observation were marked on the globe by dots on bits of paper. Next the globe was oriented for this time and a narrow strip of paper passed through the moon's centre so as to be perpendicular to a second strip joining the two bodies. Since the first fixes the direction of the line drawn through the cusps, we have only to measure the angle which it makes with the circle of the horizon in order to obtain the desired check.

The angle found in this manner for the February observation was 44° ; for that in October, 52° . The trigonometrical checks are, respectively, 45° and 53° .

These and similar exercises ought to dispel the popular notion that a portent to foretell the weather is shown by the moon's horns.

143. Synodic period. — The difficulty in finding the synodic period of the moon (Young, Art. 229, E. Art. 141) directly from observation lies in the fact that there may be an error of several hours in fixing with the unaided eye the instant of the phase. The danger of large errors will, however, be diminished if the moon is watched on three nights instead of one; that is, on the night designated for the particular phase in a common almanac, and on those preceding and following.

OBSERVATION 1. — S. C. O. On Thursday, Dec. 10, 1896, the moon was near first quarter. At 6^h 30^m P.M. the bounding line of the bright part of the moon was very clearly concave.

OBSERVATION 2. — S. C. O., Friday, Dec. 11, 1896. Between six and seven o'clock in the evening the moon was examined a number of times. Once the terminator seemed a little concave, and later a trifle convex, but at other times it appeared to be a straight line, so the instant of first quarter was fixed at 6^h 30^m P.M.

OBSERVATION 3. — S. C. O., Saturday, Dec. 12, 1896. At 6^h 30^m P.M. the terminator was evidently curved outward, but its deviation from a straight line was not so marked as on the 10th. So I estimated that first quarter did not come midway between 6^h 30^m on December 10 and 12, but $\frac{2}{3}$ of that interval after the 10th, or on December 11, 11^h 18^m P.M.

The mean of these two times, 6^h 30^m and 11^h 18^m, brings the time of first quarter at 8^h 54^m P.M., December 11.

In the following February it was cloudy on the 8th, the night before first quarter, but observations like those just described were made on the 9th and 10th and fixed the phase on February 9, 4^h 20^m P.M.

No magnifying power was employed in these observations, and care was taken not to know the time of the phase nearer than the whole day.

From these two determinations of the time of first quarter we find the average length of each of the two synodic months

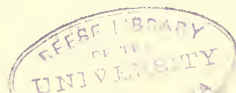

included to be $29^d 21^h.7$. The length found from the Ephemeris is $29^d 21^h.5$.

144. Sidereal period. — If we locate the moon with regard to the stars at a given day, hour, and minute, and then note the time when the moon comes again into like position with regard to the same stars, the interval of time is one or more sidereal months. Owing, however, to the changing position of the moon's path on the celestial sphere (§ 81) a return to the exact position of the first observation should not be expected; and since the time of the second observation is always conditioned by clouds and daylight, the final hour and minute will not usually be noted directly, but derived, as in the following illustration.

OBSERVATION. — S. C. O., Tuesday, March 16, 1897. The moon was nearly full, but it was favorably placed near Jupiter and Regulus, and the following estimates were made to fix its position at $6^h 45^m$ P.M.

The distance separating Jupiter and the moon at this time seemed equal to each of the star-lines $\gamma\zeta$ Leonis, $\alpha\beta$ Geminorum, and β Orionis β Eridani (§ 6); the distance between the moon and Regulus appeared equal to that between Regulus and Jupiter minus two thirds of the moon's diameter; and the angle formed at Regulus by lines drawn from Jupiter and the moon was called 45° .

These relations are expressed much more concisely in the following notation, which will be employed hereafter in giving similar data:

$$\begin{aligned} \mathcal{D} &= \gamma \zeta \text{ Leonis} = \alpha \beta \text{ Gemin.} = \beta \text{ Orionis } \beta \text{ Eridani} \\ \mathcal{D} a &= a \mathcal{D} - \frac{2}{3} \mathcal{D}'\text{'s diameter} \\ \angle \mathcal{D} a \mathcal{D} &= 45^\circ \end{aligned} \quad (\text{H. W. B.})$$

In plotting the position thus determined, the mean of the three distances was taken, and Jupiter was located directly by coördinates from the Ephemeris. To avoid marking the star-

maps, tracing paper was laid over the stars employed and their places fixed by dots. Measures of observed distance and angle then gave the position of the moon numbered 1 in Fig. 16. The one numbered 2 was obtained in a similar manner between nine and ten o'clock on the same evening. About two months later, on the night of May 10, the same observer at the same place mapped the moon a third time when near Jupiter and Regulus.

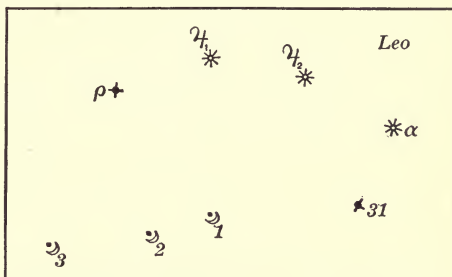

FIG. 16. — Sidereal Period of the Moon.

In order to find the sidereal period of the moon, we have then three positions at the following times:

| | | | |
|-------------|-----------|--------------------------------|------|
| Position 1, | March 16, | 6 ^h 45 ^m | P.M. |
| “ 2, | “ “ | 9 30 | “ |
| “ 3, | May 10, | 9 0 | “ |

If we assume that the motion of the moon among the stars is uniform, we can ascertain from the data given at what time on March 16 the moon passed nearest the point marked 3 on the map.

Measuring with rectangular paper, we find the distance between positions 1 and 3 (Fig. 16) to be 2.67 times that between 1 and 2. Now, since it took the moon 2^h 45^m to pass from 1 to 2, the time required to move from 1 to the point nearest 3 should equal 2.67 (2^h 45^m), or 7^h 21^m. This quantity added to 6^h 45^m, the time when the moon was at position 1, gives 2^h 6^m A.M. as the required time when the moon was nearest 3 on March 17.

But on May 10, at 9^h 0^m P.M., the moon was nearly at the same point; therefore the interval between these dates, 54^d 18^h 9, is

the approximate length of the two sidereal months intervening, and the average length of each month is $27^d 9^h.4$.

This value for the sidereal month may be checked by finding from the Ephemeris the hour and minute on March 17 when the moon's longitude was the same as at $9^h 0^m$ May 10. Half the difference between the date of the May observation and that for March, thus determined, makes the sidereal month $27^d 9^h.6$ in length; that is, $0^h.2$ longer than the period found by observation.

The month thus obtained is, strictly speaking, the tropical month, but the mean tropical and sidereal months differ only by about 6 seconds (Proctor's "Moon," p. 85).

145. Time from altitude. — The determination of time from an altitude of the moon is an especially interesting problem because it is one of the very few within the province of naked-eye observers which requires the introduction of parallax (§ 136). After declination and zenith distance have been corrected for the disturbing effects of this factor, the moon's hour-angle can be calculated by the same formula as that employed for the sun (§ 40 (6)), and from the hour-angle any desired time is readily derived.

EXAMPLE. — S. C. O., Dec. 19, 1896. The altitude of the centre of the moon measured as usual with the Circles was found to be $38^\circ 25'.5$ at $7^h 41^m 18^s$ P.M. What was the error of the watch determined from the observation?

Since here, as in Section 135, an assumed value of the time sought is required, let us take as the first approximation the time given to the nearest minute; that is, $7^h 41^m$. Entering the Ephemeris with $12^h 41^m$, the corresponding Greenwich time, we take out the right ascension, $5^h 46^m 46^s$, and the declination $+27^\circ 17'.4$. The zenith distance, ζ'' , found directly from the altitude, is $51^\circ 34'.5$. The next step is to obtain the values for declination and zenith distance, δ_1 and ζ_1 , corrected for parallax.

For this purpose we may employ the following formulæ (Chauvenet, Vol. I, Equations (435)):

$$\begin{aligned}\delta_1 &= \delta + e^2 \pi_1 \sin \phi \cos \delta \\ \zeta_1 &= \zeta' - \pi_1 \sin \zeta'\end{aligned}$$

in which δ and ϕ have their usual significations, ζ' is the observed zenith distance corrected for refraction, π_1 is the horizontal parallax taken from the Ephemeris affected with a small increment (Chauvenet, Table XIII), and $\log e^2 = 7.8244$.

We have then :

$$\begin{array}{rcl} \delta & = & + 27^\circ 17'.4 \\ e^2 \pi_1 \sin \phi \cos \delta & = & \frac{+ 0.2}{27 \ 17.6} \\ \delta_1 & = & \frac{27 \ 17.6}{27 \ 17.6} \end{array} \qquad \begin{array}{rcl} \zeta'' & = & 51^\circ 34'.5 \\ r & = & + 1.2 \\ \zeta' & = & \frac{51 \ 35.7}{51 \ 35.7} \end{array}$$

$$\left. \begin{array}{l} \pi = 55'.5 \\ \Delta \pi = 0.1 \\ \pi_1 = 55'.6 \end{array} \right\} \pi_1 \sin \zeta' = \frac{43.6}{55.6}$$

$$\zeta_1 = \frac{50 \ 52.1}{50 \ 52.1}$$

With these values of δ and ζ the required hour-angle is computed as in Section 108.

| | |
|--|---|
| $\phi = 42^\circ 19'.0$ | $\log \sec \phi = 0.13110$ |
| $\delta_1 = \frac{27 \ 17.6}{27 \ 17.6}$ | $\log \sec \delta = 0.05126$ |
| $\phi - \delta_1 = \frac{15 \ 1.4}{15 \ 1.4}$ | $\log \sin \frac{1}{2} \text{ sum} = 9.73548$ |
| $\zeta_1 = \frac{50 \ 52.1}{50 \ 52.1}$ | $\log \sin \frac{1}{2} \text{ diff.} = 9.48819$ |
| $\frac{1}{2} \text{ sum} = \frac{32 \ 56.8}{32 \ 56.8}$ | <u>19.40603</u> |
| $\frac{1}{2} \text{ diff.} = \frac{17 \ 55.4}{17 \ 55.4}$ | $\log \sin \frac{1}{2} t = 9.70302$ |
| $t = - 60^\circ 37'.2 = - 4^{\text{h}} 2^{\text{m}} 29^{\text{s}}$ | $\frac{1}{2} t = - 30^\circ 18'.6$ |

The correction $\Delta \pi$ is so small that it may be omitted, if tables giving its value are not at hand. In this example the omission will not appreciably affect the final result.

Having now the moon's approximate right ascension at the time of observation, and its hour-angle derived from altitude, we find sidereal time and thence the mean time, $7^{\text{h}} 47^{\text{m}} 52^{\text{s}}$, exactly as in Section 135.

Employing the Greenwich time, $12^{\text{h}} 38^{\text{m}} 25^{\text{s}}$, which corre-

sponds to this local time, we take from the Ephemeris a more accurate value of the right ascension, $5^{\text{h}} 46^{\text{m}} 40^{\text{s}}$, and repeat the operation of finding sidereal and mean time. As a third approximation introduces no change in right ascension, and the difference in declination is too small to affect the hour-angle, the time derived from $5^{\text{h}} 46^{\text{m}} 40^{\text{s}}$ is the most accurate to be obtained from the observation. This mean local time is $7^{\text{h}} 47^{\text{m}} 46^{\text{s}}$ P.M., or $7^{\text{h}} 38^{\text{m}} 19^{\text{s}}$ P.M. is the standard time obtained from the measured altitude of the moon.

Since the time recorded by the watch was $7^{\text{h}} 41^{\text{m}} 18^{\text{s}}$ P.M., the watch was $2^{\text{m}} 59^{\text{s}}$ fast by the observation, but its error correct within a second was in fact $-3^{\text{m}} 51^{\text{s}}$ (§ 69), making the error of the observation 52^{s} .

A result nearly as accurate as that just given may be obtained by a much shorter process. Practically it is necessary to introduce only one additional correction before employing ϕ , δ , and ζ exactly as in finding the hour-angle of the sun. The required correction, which must be subtracted from ζ' , is $\pi \sin \zeta'$, π being the value of parallax found directly from the Ephemeris, and ζ' the observed zenith distance corrected for refraction.

Taking then the same example as that given above, we have the uncorrected value of δ equal to $+27^{\circ} 17'.4$, and ζ_1 is found to be $50^{\circ} 52'.2$, whence the hour-angle deduced as usual is $-4^{\text{h}} 2^{\text{m}} 28^{\text{s}}$. Proceeding next, as in Section 135, to find mean time by making use of the moon's meridian passage at Washington, we have:

| | |
|--|---|
| Transit of moon at Washington | = $12^{\text{h}} 0^{\text{m}} 7^{\text{s}}$ |
| “Diff. for 1 Hr.” = $2^{\text{m}}.273$. \therefore Corr. = $2^{\text{m}}.273 \times 4.34$ | = $\frac{9 \ 52}{}$ |
| Transit of moon at “eastern meridian” | = $11 \ 50 \ 15$ |
| “Eastern meridian” east of Northampton | = $\frac{4 \ 2 \ 28}{}$ |
| Local mean time at Northampton | = $7 \ 47 \ 47$ |

This time differs, we see, only one second from that derived by the longer method.

When the moon is on the horizon this method may be still further shortened by subtracting the value for π directly from the zenith distance, $90^\circ 52'.5$ (Young, Art. 131).

146. Time from a meridian transit. — S. C. O., Apr. 16, 1897. The transit tube was placed and adjusted as described in Section 112. No artificial light was required, as the plumb lines were well illuminated by the moon itself. The meridian altitude of the moon was about 33° , and it was so nearly full that the naked eye could detect no deviation from a perfectly circular form.

Three times were recorded (§ 112, Obs. 2), and their mean, $11^h 38^m 57^s$ P.M., gave the observed time of the transit of the moon's centre.

Now, if we knew the true local time of the moon's meridian passage, the difference between that and the observed time would give directly the error of the watch employed.

In order to find this correct time we take out the Washington time of transit and deduce from that the approximate Greenwich time, whence is found the moon's right ascension at meridian passage, or the sidereal time at that instant. Thus, we have :

| | |
|-------------------------------|-----------------------------------|
| Washington time of transit | = $11^h 49^m.0$ |
| Corr. = $2^m.34 \times 0.29$ | = $\underline{\quad 0.7}$ |
| Northampton time of transit | = $11 \ 48 \ .3$ |
| Northampton west of Greenwich | = $\underline{\quad 4 \ 50 \ .6}$ |
| Greenwich time of transit | = $16 \ 38 \ .9$ |

With this Greenwich time we find from the Ephemeris the moon's right ascension or sidereal time at transit to be $13^h 30^m 34^s$. Since a second approximation (§ 145) has no appreciable effect, this is taken as the true time of meridian passage. Reduced to mean time it equals $11^h 48^m 17^s$, or $11^h 38^m 50^s$ standard time P.M.

According then to the observation, the error of the watch

was -7^s ; but comparisons made with the sidereal clock both before and after the moon's transit gave an error of -5^s (§ 54). So the transit was observed 2^s late.

147. Longitude from moon culmination. — When the local time of the moon's transit has been observed, we can ascertain the longitude of the place by comparing that time with the time of meridian passage at Washington or Greenwich.

It will be of interest to find in this manner the longitude of Northampton by means of the transit described in the preceding section, though the method has a serious drawback, as an error of two or three seconds in the observation causes an error of a minute or more in the resulting longitude (Young, Art. 120).

By employing the error of the watch derived to the nearest second, independently of the observation, the standard time when the moon crossed the meridian of Northampton, Apr. 16, 1897, was $11^h 38^m 52^s$ P.M. (§ 146). The corresponding sidereal time, or right ascension of the moon, is $13^h 30^m 36^s.3$; but on the same date its right ascension at the Washington transit was $13^h 31^m 18^s.12$. So the change in the moon's right ascension while passing from the one meridian to the other was $41^s.82$. If second differences (Chauvenet, Vol. I, Art. 63) are neglected, the change in the moon's right ascension for one hour of longitude may be taken for the time involved as $150^s.56$. Therefore, the conclusion follows that a change of $41^s.82$ in right ascension corresponds to a change in longitude equal to $\frac{41.82}{150.56}$ of 60^m , or $16^m.7$. Since the true difference in longitude between these places is $17^m.7$, the value obtained from the observed culmination of the moon is too small by a minute.

148. Surface markings. — It is hopeless, without magnifying power, to attempt detail in drawing the markings on the lunar

surface. But sketches ought to be made so that prominent objects on one can be identified on another, if nearly the same phase has been observed.

The following illustrations were obtained when the moon was nearly full, the first on the morning of July 26, 1896 (Fig. 17),

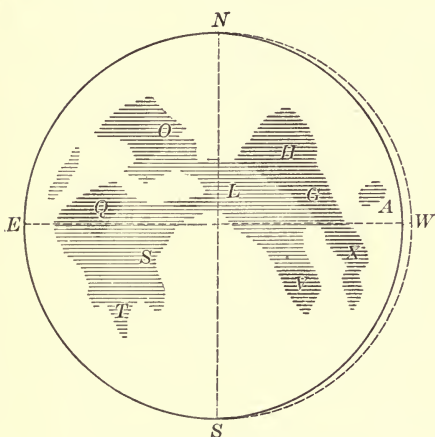

FIG. 17. — Age 15.45 days.

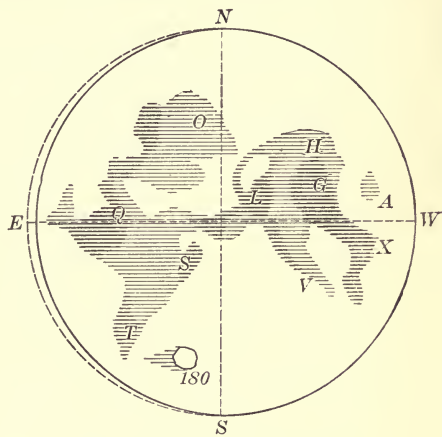

FIG. 18. — Age 14.96 days.

THE MOON WITH THE NAKED EYE.

and the second on the evening of April 16, 1897 (Fig. 18). Care was taken not to consult the first drawing until after the second was finished. The letters in the figures are those usually employed to designate the principal seas.

Comparing the two sketches, we find the following seas in each:

| | |
|---------------------------------|------------------------------|
| <i>S.</i> Mare Nubium. | <i>X.</i> Mare Fœcunditatis. |
| <i>Q.</i> Oceanus Procellarum. | <i>V.</i> Mare Nectaris. |
| <i>O.</i> Mare Imbrium. | <i>A.</i> Mare Crisium. |
| <i>H.</i> Mare Serenitatis. | <i>L.</i> Mare Vaporum. |
| <i>G.</i> Mare Tranquillitatis. | <i>T.</i> Mare Humorum. |

The formation marked 180 in Fig. 18 was noted as especially bright, and it is probable that Tycho was seen. (A. E. T.)

In the illustrations it has seemed impossible to reproduce the soft outlines given in the original drawings.

149. The total eclipse of Sept. 3, 1895.—From the first contact of the shadow to the end of totality, the eclipse of September, 1895, was watched from the steps of Smith College Observatory. The end of the whole eclipse was recorded at 84 Elm Street. No magnifying power was employed, except in the two instances when an opera-glass is mentioned.

At 10^h 50^m P.M., the eastern limb of the moon was darkened, and a little later, at 11^h 3^m, the shadow was first visible on the upper part of the eastern limb. It looked then like a dark cloud with a feathery edge coming upon the moon.

No lunar markings were distinguished within the shadow, but its approach to marked features on the moon could be determined approximately. Thus, at 11^h 30^m the shadow had reached Mare Serenitatis. The division line between the bright and eclipsed portions of the moon appeared quite sharp to the naked eye, but less distinct when seen with an opera-glass. It made, of course, a concave boundary for the bright part of the moon.

About an hour after the eclipse had begun, the color of the shadow near the eastern limb was reddish brown, but that toward the centre, dark gray, as at the beginning. The whole effect was like that of the "old moon in the new moon's arms" when the moon is about two days old. At this time the principal seas were visible within the eclipsed part, and by means of the opera-glass it was seen that the shadow now covered all of Mare Crisium.

When totally eclipsed, the moon was distinctly visible, dark at the centre, but surrounded by a somewhat lighter ring. That part of the moon which had just passed into the shadow had a yellowish or greenish tinge, but the prevailing colors were dark gray and coppery red.

A narrow line of light on the upper part of the eastern limb at 1^h48^m A.M. showed that totality had ended.

The last contact of the shadow came at 2^h54^m A.M., September 4, making the entire duration of the eclipse 3^h51^m. The Ephemeris gives 3^h54^m.
(A. E. T.)

150. Lunar halo.—S. C. O., Thursday, Jan. 27, 1898. About seven o'clock this evening a ring of colored light was seen around the moon. Its diameter, according to my estimate, was equal to the star-line $\alpha\theta$ Aurigæ (§ 6); another observer called it three fourths of the line $\gamma\beta$ Orionis. Expressed in degrees, the two measures are 12° and 11°, giving a mean diameter of 12° (§ 5).

The outer band was clearly defined, and dark blue-green in color. Its width was a third of the radius, or about 2°. Next came a dark, narrow rift, and then a reddish-brown band half as wide as the first, ill-defined on the inner edge and shading to orange at its centre. The light surrounding the moon inside these bands was white with a slight tinge of green. The moon itself appeared slightly eccentric, as if it were a little below and to the right of the true centre of the halo.

Within half an hour the halo disappeared and reappeared again. When seen the second time, its diameter seemed larger, the moon more sharply defined, and the reddish-brown band shaded gradually to deep red on the outer edge and to yellow on the inner edge. Soon after these notes were taken, clouds put an end to further observations.
(H. W. B.)

CHAPTER VII.

PLANETS, COMETS, AND SHOOTING STARS.

OBSERVATIONS of the sun, moon, and stars can be taken at almost any time, but when a bright planet is favorably situated it should receive special attention ; and if a comet is visible to the naked eye or with an opera-glass, the "working-list" (§ 1) for a night or two should deal with few if any other objects.

The actual study of planets or comets will doubtless suggest additional questions beside those given here. In this, as in other chapters, the list of questions is designed to be suggestive rather than exhaustive. All answers are to be obtained from observation. The time is eastern standard time unless the contrary is stated.

QUESTIONS.

151. Color, brightness, and face appearance of planets.

1. What is the color of each of the bright planets, Mercury, Venus, Mars, Jupiter, and Saturn ?
2. If two or more are visible at once, how do they compare in color ?
3. In what order do you rank the five bright planets with regard to brightness ?
4. How does a given planet compare in brightness with several bright stars visible at the same time ?
5. How does it differ in color from several bright stars visible at the same time ?
6. Is any other difference noted between planets and stars with the naked eye ? With an opera-glass ?
7. At the times when Mercury is brightest, when is it seen in the east before sunrise and when in the west after sunset ?
8. When Venus is visible in broad daylight, what is its angular distance from the sun ?

9. Have you seen this planet cast a shadow at night?
10. When the planet seems brightest, how long is the interval before or after inferior conjunction?
11. At an August opposition how does Mars compare in brightness with Venus, Jupiter, or Saturn?
12. What change in the brightness of Mars is noted between opposition and quadrature? What between quadrature and conjunction?
13. How do variations in the brightness of Jupiter compare with those of Mars?
14. Does the transit tube have any effect upon the appearance of a bright planet?

152. Identification and visibility of planets.

1. How can it be proved that some bright star has not been mistaken for Mercury?
2. Are you able to see Uranus with the naked eye?
3. How does it look through an opera-glass?
4. How can Uranus be identified with certainty?
5. When one of the bright minor planets is near opposition, how can it be identified?
6. How many of Jupiter's moons are visible with opera-glasses? With field-glasses?
7. How are these satellites distinguished with certainty from faint stars?
8. What result is obtained by trying to see the moons of Jupiter in a common mirror?
9. If the same test is made with Venus or the moon, how do results compare?

153. Conjunctions.

1. When and where do you watch for an inferior planet before and after it is in superior conjunction with the sun?
2. When a planet is in conjunction with the moon, does the moon pass above or below the planet?
3. What is the smallest distance noted between them?
4. What points about relative motion and distance are ascer-

tained when two planets are watched near conjunction? When a planet and star are observed?

154. Apparent motion.

1. When Venus is an evening star, how does its setting point compare with that of the sun?

2. On a given night, how far is the setting point from the west point of the horizon?

3. During an interval of a week or ten days, by how many degrees does the setting point change its position? Is the motion north or south?

4. During this interval how do the times of setting vary?

5. Why is it difficult to find the meridian altitude of Venus?

6. Does the meridian altitude of a particular planet vary from night to night? From week to week?

7. Does the same planet come to the meridian at the same time from night to night?

8. If not, how much earlier or later is its time of transit?

9. On a given night what is the altitude and azimuth of any bright planet?

10. How many degrees does each coördinate change in an hour?

11. What is the difference in altitude and azimuth between the planet and a neighboring star?

12. Is the planet moving toward the east or toward the west quarter of the horizon?

13. Is the direction of this motion the same or different for different planets?

14. What effect, if any, has a change in a planet's declination upon its diurnal path?

15. Is a planet's hourly rate of motion the same as that of a star?

16. How does the diurnal path of a planet differ from that of a star?

155. Motion referred to equator and ecliptic.

1. If a planet is referred directly to the celestial equator, what is its estimated right ascension and declination?

2. What values for these coördinates are obtained by mapping the planet with bright stars in its vicinity? By making measures with the cross-staff?

3. What values are derived by calculation from an observed altitude and azimuth?

4. In how short a time is a difference in these coördinates detected?

5. What latitude and longitude are obtained for a planet by direct estimate?

6. What is the smallest distance observed between a planet and the ecliptic? What is the largest?

156. Motion referred to stars.

1. In what constellation do you find a given planet on a particular night?

2. How long does it remain in that constellation?

3. What motion is obtained in right ascension and declination from two maps of Venus or of Mars separated by a week or ten days?

4. Which moves the faster among the stars, Venus or the moon?

5. What intimation does such an observation give with regard to the relative distances of the two bodies from the earth?

6. Which moves the faster among the stars, Mars or Jupiter? Jupiter or Saturn?

7. By means of maps taken each week for two or three months, what path do you lay down for a planet?

8. Is the planet moving east or west among the stars?

9. Does the same planet sometimes move east and sometimes west?

10. With regard to these directions how are different planets moving at the same time?

11. Over how many degrees does a planet pass when retrograding?

12. Is there a time when it appears stationary for a week or more?

157. Physical appearance of comets.

1. Is any nucleus visible in the comet observed?

2. Is it poorly defined or distinct and star-like? Is it centrally placed in the coma?

3. What is the shape of the coma? Is it uniform in brightness?
4. In what direction does the tail point with reference to the sun? Is it straight or curved?
5. What is its length, taking the diameter of the coma as unity? What is its length in degrees?
6. Is more than one tail visible?
7. On different nights, what variations are detected in nucleus, coma, and tail?
8. Is a star ever seen through any part of a comet?

158. Motion of comets.

1. From maps made at intervals of a few days during several weeks, what path is assigned to a particular comet?
2. Is its motion east or west when referred to the stars? Does it have any motion toward the north or south?
3. On a given night how does observed motion among the stars compare with the corresponding value given in the ephemeris of the comet?
4. Over how many degrees does it pass in a week or two?
5. Does it move more slowly during the first or during the last part of its appearance?
6. How long is it visible to the naked eye? How long with an opera-glass?
7. When a comet is above the horizon, how does its diurnal path compare with the corresponding path of a star near it?
8. If the altitude and azimuth of a comet and neighboring star are observed at the same sidereal time on several nights, are the differences in these coördinates constant?
9. After an interval of several weeks, how do the two paths compare?

159. Shooting stars.

1. What is the largest number of shooting stars counted in a night when there is a shower? The largest number in an hour?
2. If a night is taken at random, how many are seen in an hour?
3. While a shooting star is in sight, how far can you count beginning with one?

4. What stars are employed to fix the beginning and end of its path?
5. What is the approximate length of the path in degrees?
6. How does a given shooting star compare in brightness with a star or planet near it?
7. How do three or four shooting stars compare with one another in size and length of train?
8. How is a "radiant" actually located during a meteoric shower?

SUGGESTIONS AND ILLUSTRATIONS.

160. Relative color and brightness of the five bright planets. — On Wednesday evening, Apr. 21, 1897, all the bright planets were visible between seven and ten o'clock, though Mercury and Venus set before Saturn rose.

Jupiter was brighter than Venus for the first time since the two appeared together in the evening sky in December. The latter planet during the preceding week had lost light rapidly; for in a note of April 16 it was stated: "Venus is by far the brightest object in the whole heavens; neither Sirius nor Jupiter with its advantage of high altitude is bright enough to use as a comparison star" (§ 205). In color Jupiter and Venus were much alike. If anything Venus was even more yellow than Jupiter, a circumstance naturally accounted for by its low altitude.

At half after seven, when Mercury was less than 10° and Mars over 40° high, the two appeared strikingly alike, though Mars was redder and perhaps a little brighter. About twenty minutes later both planets were brighter and redder, but there was no perceptible change in their relative colors. Mercury was then, however, decidedly the brighter, no account being taken of its low altitude and the effects of the sunset glow.

It was difficult on this date to make any comparison between Jupiter and Mars; the latter by contrast looked so small and insignificant, and was so red in color, while Jupiter appeared

white with a strong tinge of yellow. Saturn and Jupiter, on the other hand, were not so totally unlike, though Jupiter was a great deal brighter, even if allowance were made for its high altitude and Saturn's position near the horizon. The latter planet appeared dull in color and a deeper yellow than Jupiter.

In making this examination of the planets, no magnifying power was employed.

161. Mercury identified. — S. C. O., Wednesday, Jan. 6, 1897. From the Old Farmer's Almanac this evening was known to be a favorable time for seeing Mercury in the west, and about half an hour after sunset a bright reddish object appeared above the belt of clouds which extended along the western horizon. Since at the place of observation it is not safe to depend upon steadiness of light in identifying Mercury, it was necessary to ascertain whether there were any bright stars in the vicinity which could be mistaken for the planet.

Judging from the sunset glow, it was seen at once that the object investigated was near the ecliptic, certainly too far north for Fomalhaut and too far south for Altair. A more accurate position was obtained by two hasty measures made with the Circles through a break in the clouds, which after the first view had obscured the object most of the time. The altitude and azimuth thus determined were found to be $6^{\circ}.8$ and $55^{\circ}.5$.

Now it is clear that if the corresponding place of the planet, fixed by the Ephemeris and celestial globe, agrees closely with this position, all doubt about the object will be removed.

By means of right ascension and declination Mercury was located on the celestial globe for the time of observation, the globe oriented for that time, and the altitude found to be $6^{\circ}.6$ and azimuth $55^{\circ}.6$ (§ 74, Ex. 2). Mercury was, therefore, the object seen.

162. Visibility of Venus in the daytime. — In 1896–97 I watched Venus from the time when it appeared at sunset till it became

visible on the meridian. The following extracts from the observations give an idea of the rate of change from October to March. The places mentioned are in or near Northampton, Mass.

Hadley Meadows, Tuesday, Oct. 27, 1896. Venus was easily seen when three fourths of the sun's disk was still above the horizon.

Garden fence, 84 Elm Street, Saturday, November 14. Looking at the point in the sky where the planet was visible some days earlier, I found it a quarter of an hour before sunset.

84 Elm Street, Thursday, December 3. I saw Venus 50^m before the sun set, and fixed its place in the sky approximately by two pickets and the top of an apple tree.

84 Elm Street, Thursday, December 17. It was possible to see Venus this evening 1^h 35^m before sunset.

84 Elm Street, Thursday, December 24. Venus was seen at first glance from a window at 1^h 45^m P.M., about an hour before the planet's meridian passage.

Monday, March 8, 1897. When going to the observatory at 11 A.M., I looked up a little to the east of my imaginary meridian to find Venus, and saw it immediately. The planet was also visible at noon, though its greatest brilliancy did not come till about two weeks later, on March 21.

Between December and March there was no difficulty in seeing Venus on any clear day, at any hour in the afternoon.

(A. E. T.)

163. Conjunction of Mercury and Venus. — Two heavenly bodies are said to be in conjunction when they have the same longitude or right ascension. Since, however, they may differ in latitude or declination, we often find objects several degrees apart at the instant of conjunction. This angular distance, measured on the arc of a great circle, can be derived approximately from observations made with the Circles.

Thus, if the altitude and azimuth of two bodies have been

measured at the same time, their relative positions at that time are fixed on the celestial sphere, and the number of degrees between them may be calculated just as when right ascension and declination are given (§ 72, Ex. 3). Since conjunction is as likely to occur in the daytime or when the bodies are below the horizon, as at a convenient hour in the evening, it is well, if possible, to observe on three nights, that of the conjunction and those immediately before and after.

EXAMPLE. — According to Jayne's Almanac, Venus and Mercury were in conjunction Apr. 17, 1897, and from observations made that evening as usual with the Circles the following data, corrected for refraction and error of watch, were obtained:

| Place. | Time. | Object. | Altitude. | Azimuth. | Observer. |
|----------|-----------------------------------|---------|-----------|------------|-----------|
| S. C. O. | 7 ^h 17 ^m .3 | Venus | 9° 57'.5 | 111° 17'.0 | M. E. B. |
| S. C. O. | 7 28 .0 | Mercury | 5 25.5 | 108 42.0 | A. E. T. |

What was the distance between the two planets at the mean of the times, 7^h 23^m P.M.?

Since the planets were near together and the observations differed little in time, we may treat the measures as if they were all taken at the mean of the times, especially as an approximate value only is desired.

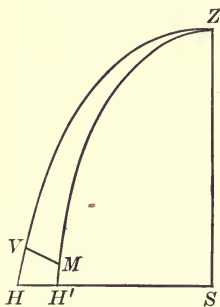

FIG. 19.

We are then ready for the numerical example, which consists in finding the side VZM (Fig. 19) in the spherical triangle VZM , where Z is the zenith, V and M the positions of Venus and Mercury, and ZH and ZH' vertical circles drawn through these bodies.

The sides ZV and ZM are known, as they are the complements of the observed altitudes, and the included angle VZM , since it is the difference between the azimuths. By the common trigonometrical formula (§ 72) we have:

$$\begin{array}{rcl}
 ZM = 84^\circ 34'.5 & & \\
 VZM = 2 \ 35.0 & \log \cos VZM = 9.99956 & \\
 ZV = 80 \ 2.5 & \log \tan ZV = \underline{0.75553} & \log \cos ZV = 9.23788 \\
 m = 80 \ 2.0 & \log \tan m = \underline{0.75509} & \log \sec m = 0.76177 \\
 ZM - m = 4 \ 32.5 & & \log \cos (ZM - m) = \underline{9.99864} \\
 MV = 5^\circ 5' = 5^\circ.1 & & \log \cos MV = \underline{9.99829}
 \end{array}$$

On the following evening, April 18, like observations were taken, and the angular distance separating the planets was found to be $4^\circ.0$.

Theoretical checks for these angles are obtained by taking out the right ascension and declination of Mercury and Venus for the given times, and making solutions similar to that above. Thus, we find that the space between the planets at the first observation was $4^\circ.9$, and at the second $5^\circ.0$.

It is seen by referring to "Planetary Constellations" in the Ephemeris that the actual time of conjunction came at 4^{h} A.M. April 17, or $16^{\text{d}} 16^{\text{h}}$ astronomical date (§ 33). Since Mercury and Venus were then separated by $5^\circ.2$, and since this angle was changing very slowly, the observed value, $5^\circ.1$, though obtained more than half a day late, was very nearly correct, doubtless owing in part to accident.

164. Maximum elongation of Venus. — The angular distance of a planet from the sun as seen from the earth is called its angle of elongation. It is measured by the arc of a great circle drawn on the celestial sphere between the centres of the two bodies. For Venus this angle reaches a maximum about ten weeks before or after inferior conjunction (Young, Art. 564, E. Art. 321), and according to the method explained in the preceding section its approximate value may be found at any time.

EXAMPLE. — On the evening of Feb. 24, 1897, about a week after Venus had passed its greatest eastern elongation, the following observations were obtained:

| Place. | Time. | Object. | Altitude. | Azimuth. | Observer. |
|----------|-----------------------------------|---------|-----------|----------|-----------|
| S. C. O. | 5 ^h 19 ^m .3 | Sun | 1° 20' | 75° 38' | H. W. B. |
| S. C. O. | 5 27 .6 | Venus | 43 43 | 59 40 | H. W. B. |

What was the angle of elongation at 5^h 23^m P.M., if we assume that the measures were all made at that time?

The two bodies were so far apart on the celestial sphere, and so differently placed with regard to the horizon, that a close agreement between theory and observation is not to be expected. The values actually obtained were 44°.7 from altitude and azimuth, and 46°.4 from right ascension and declination. This theoretical angle differs little from 46°.6, which is given in the Ephemeris as the maximum angle at eastern elongation, February 16.

165. Elongation of Venus near inferior conjunction. — Since the angle of elongation diminishes as a body approaches the sun, it should reach a minimum at conjunction. Now as Venus passed inferior conjunction Apr. 28, 1897, we ought to find small values for the angle in the latter part of that month. Observations were accordingly taken on the 18th and 21st, but after that clouds obscured the planet till it was too near the sun to be visible.

On the 18th, the positions fixed for the two bodies corresponded to times nearly 40^m apart, an interval too large to be neglected in obtaining even approximate results. We see, however, by consulting the observing note-book that on this evening the coördinates of Venus were read twice within the hour and a half included in the observations. If, then, we assume that the planet's rate of motion in altitude and azimuth was approximately the same in the two halves of this period, it is possible to carry the position of Venus back to that occupied when the sun was observed. In this manner we obtain for the planet an altitude of 17° 39' and an azimuth of 103° 47', which combined with the observed values of the sun, 1° 48' and

$103^{\circ} 26'$, make the angle of elongation $15^{\circ}.8$ (§ 163). The purely theoretical value is $16^{\circ}.4$.

On April 21 there were two observations of the sun, and its position was carried forward about an hour, so as to agree in time with that of Venus. The resulting angle of elongation is found to be $11^{\circ}.7$, while theory gives $12^{\circ}.3$.

166. Diurnal paths of Venus and β Orionis.— Observations of Venus and β Orionis were made on three evenings in February and March, 1897, in order to locate their diurnal paths.

As far as possible both objects were followed from the meridian to the western horizon, the altitude and azimuth of each being read every hour (§ 107). The

resulting curves obtained by plotting as usual (§ 111) are shown in Fig. 20.

(H. W. B.)

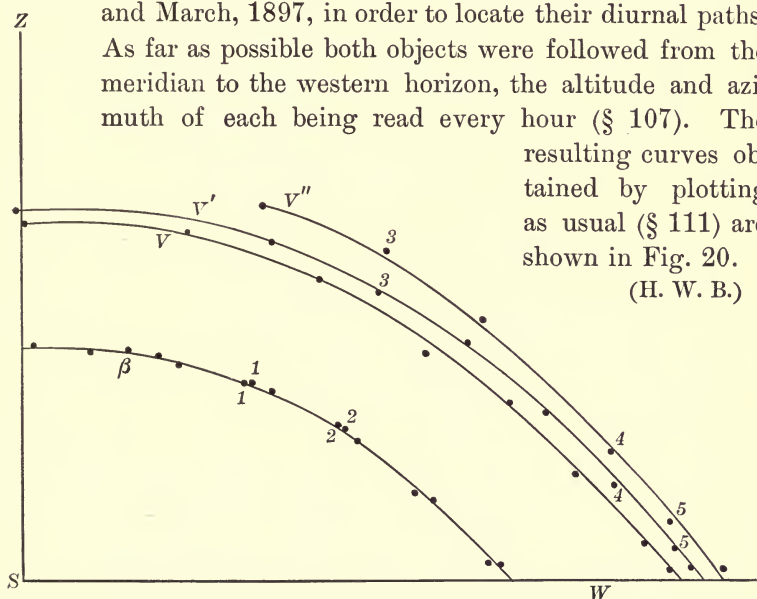

FIG. 20. — Diurnal Paths of Venus and β Orionis.

As in similar illustrations (Figs. 13 and 15), Z marks the zenith, and S and W the south and west points. The lower curve β is the path of the star, and the three above are those determined for Venus in the order of observation. That is, the one marked V corresponds to February 24, V' to March 4, and V'' to March 11.

The sidereal times of several observations on March 11 were

made to agree with the sidereal times recorded on March 4; and the corresponding positions thus determined are designated in the figure by the same numbers. For β Orionis they are so near together that the dots almost touch, as at 1-1 and 2-2; but for Venus they are separated, as seen in 3-3, 4-4, and 5-5.

167. Relative motion of Venus and Jupiter.—In order to find the comparative rates at which Venus and Jupiter were moving among the stars in the early part of 1897, these planets were mapped with adjacent stars in February and again in April.

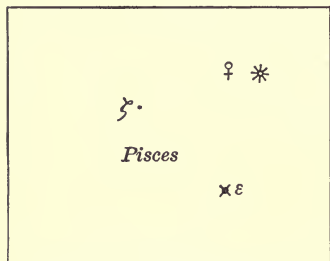

FIG. 21. — Venus in Pisces.

By means of the data thus obtained, right ascension and declination were read from a star-map, and the places of the planets marked on the celestial globe at the time of each observation. A

direct measure of the distances between these places determines the entire motion of each planet from one date to the other.

For Venus the observations and reductions are given somewhat in detail.

OBSERVATION 1.—S. C. O., Friday, Feb. 19, 1897. At 6^h 45^m P.M. Venus was above ζ and ϵ Piscium, and formed with these stars an equilateral triangle, as shown in Fig. 21.

(H. W. B.)

OBSERVATION 2.—S. C. O., Friday, Apr. 2, 1897. Venus was found in Aries to-night, near the line joining ϵ and 41. Its exact position at 8^h P.M. was fixed by the following relations (§ 144):

$$\begin{aligned}\angle \text{♀ } 41 \text{ } 1649 &= 90^\circ \\ \text{♀ } 41 &= \frac{3}{5} (41 \text{ } 1649) \\ \text{♀ } \epsilon &= \frac{2}{3} (\epsilon \delta)\end{aligned}$$

Here, and in Fig. 22, one of the fifth magnitude stars is designated by its number, 1649, in the Gesellschaft Catalogue, since

it is not named on Proctor's Atlas or on Heis's. The symbols for magnitudes given in the figures are similar to those used in Young's Uranography. (H. W. B.)

These figures for actual use were made on tracing paper, as described in Section 144; and after Venus was located the paper was laid again on Proctor's Atlas, so that the copied stars agreed with those on the map. In this position the right ascension and declination of Venus were read and the corresponding places marked on the globe, whence the motion of the planet was found to be $28^{\circ}.3$ between February 19 and April 2.

When it happens, as in Observation 1, that

no angle and only two or three measures of distance are given for fixing the place of a heavenly body, it may be located on the globe directly, without finding its coördinates from a star-map.

On the same dates when Venus was observed, maps were made for Jupiter like those given in Figs. 21 and 22. The first placed Jupiter in Leo, near the star ρ , but on April 2 the planet was found midway between ρ and α Leonis, making its motion westward among the stars. The amount determined as for Venus was $4^{\circ}.3$.

According to observation we find, therefore, that between February 19 and April 2, 1897, Venus was advancing among the stars, and Jupiter retrograding, and that the motion of the former was more than six times as rapid as that of the latter. According to calculation (§ 72, Ex. 3) the number of degrees traversed by each planet was $28^{\circ} 35'$ and $4^{\circ} 42'$.

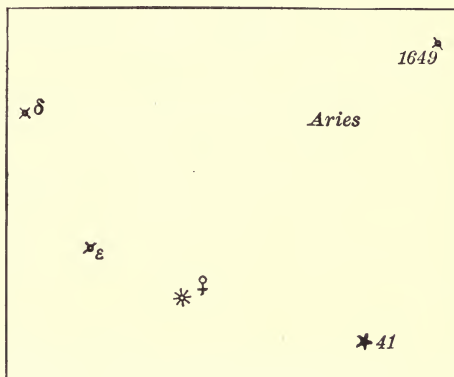

FIG. 22. — Venus in Aries.

168. Varying brightness of Mars.— The planet Mars in passing from opposition to conjunction and *vice versa* undergoes large changes in brightness (Young, Art. 579, E. Art. 328). While it is hardly possible to make a critical estimate of these variations according to the method employed for stars (§ 205), their general character is readily determined, as shown by the following notes from observations taken in 1897.

S. C. O., Wednesday, Feb. 24, 1897.— Mars was much brighter than α Tauri.

S. C. O., Monday, April 12, α Tauri was too near the horizon to be employed. α Orionis was noted as brighter than the planet, but that star is itself a variable.

S. C. O., Friday, April 16, α Orionis was too bright for a comparison star. α Canis Minoris appeared brighter than the planet, but the difference in color made it difficult to compare them.

S. C. O., Wednesday, April 21, Mars was more than half a magnitude brighter than β Geminorum.

S. C. O., Saturday, May 22, β Geminorum was about a magnitude brighter than Mars.

Without any regard to specific magnitudes the change in the brightness of Mars during the month of May was very noticeable.

169. Conjunction of Mars and the moon.— Three observations of Mars and the moon were obtained on consecutive nights in May, 1897. On the 6th, at 7^h P.M., the moon was west of Mars and distant from the planet about 2.5 times the star-line $\alpha\beta$ Geminorum (§ 6). On the following night the two bodies were much closer together, the space between them being only $\frac{1}{2}$ ($\alpha\beta$); but the third night, May 8, found them separated by 3 times ($\alpha\beta$).

The three estimates, expressed in degrees, and the corresponding globe checks are as follows:

| | | δ \mathcal{D} Obs. | δ \mathcal{D} Globe. |
|--------------------------|------|-----------------------------|-------------------------------|
| May 6, 7 ^h .0 | P.M. | 12°.0 | 10°.2 |
| May 7, 7 30 ^m | “ | 1.2 | 1.6 |
| May 8, 8 .5 | “ | 14.4 | 13.7 |

According to the Ephemeris the conjunction came May 7, at 4^h 35^m P.M., when the moon was 0°.4 from Mars. (M. P. F.)

170. Conjunction of Mars and η Cancri. — In the latter part of May, 1897, Mars approached very close to the sixth magnitude star η Cancri, but, owing to cloudy weather, only two observations could be made near the date of conjunction.

At 9^h P.M., S. C. O., Saturday, the 22d, Mars was a little below and west of the star. It was clear that the distance between them was more than a third of that between γ and δ Cancri, and it was recorded as equal to

$$\frac{1}{2} \left(\frac{1}{3} + \frac{2}{3} \right) \gamma \delta.$$

On account of the comparative brightness of Mars, and the illumination of the sky by artificial lights, it was not possible to make the observation with the unaided eye. The field-glasses employed magnified four diameters, though doubtless a lower power would have answered the purpose.

A second observation was taken under like conditions on May 25. The planet was then seen above and to the east of η Cancri, but so close to the star that recourse was had for a measuring unit to the ω 's in Scorpio, though they were in the opposite quarter of the heavens. The estimated distance was

$$\delta \eta = \omega^1 \omega^2 + \frac{1}{3} (\omega^1 \omega^2).$$

Fig. 24 (§ 171) shows the theoretical place of Mars on the 22d and 25th, and although the times do not agree exactly with those of observation, it is clear that between these dates the planet passed the star, going from west to east.

The estimates made in star-lines were reduced to degrees and minutes by the globe and by calculation (§ 72). Theoretical

values of the distances between Mars and η Cancri were also computed for the times of observation, and we have :

| Time. | | Obs. Distance. | Compt. Distance. |
|---------------------------|------|----------------|------------------|
| May 22, 9 ^h | P.M. | 1° 18' | 1° 27' |
| May 25, 9 45 ^m | “ | 0 18.9 | 0 18.8 |

The actual conjunction of planet and star occurred May 25, at 7^h A.M., with an interval, according to the Ephemeris, of only 2' between the two bodies.

In this, as well as in the preceding conjunction, we see that the critical instant came in broad daylight.

171. Path of Mars among the stars.—The course of Mars through the constellations was followed from Nov. 3, 1896, to June 23, 1897. On twenty-three nights its place was fixed by means of diagrams similar to those described in Section 167.

The resulting path is illustrated by Fig. 23, where the dots, numbered 1 to 23, mark the place of the planet at the times of the different observations (see opposite page). Positions 1 and 5 fix the beginning and end of the arc of retrogression, and the grouping of points about 5 shows that Mars was nearly stationary there. To indicate a few points not located by the regular observer their numbers are underscored. The dates corresponding to numbers as far as they are needed to give a clear idea of the path are included in the following list :

- | | |
|-------------------|--------------------|
| 1. Nov. 3, 1896. | 10. Feb. 19, 1897. |
| 2. Nov. 30. | 13. March 15. |
| 3. Dec. 10. | 17. Apr. 28. |
| 5. Jan. 18, 1897. | 20. May 22. |
| 8. Jan. 31. | 23. June 23. |

Since the path was first marked out as usual on tracing paper, it was only necessary to replace it carefully on the map in order to read directly the coördinates for any position of the planet. Hence it was easy to obtain data for computing the arc of retro-

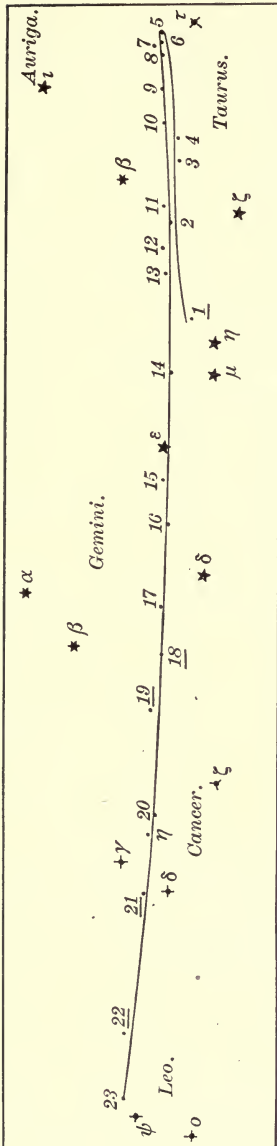

FIG. 23. — Path of Mars from Observation, 1896-97.

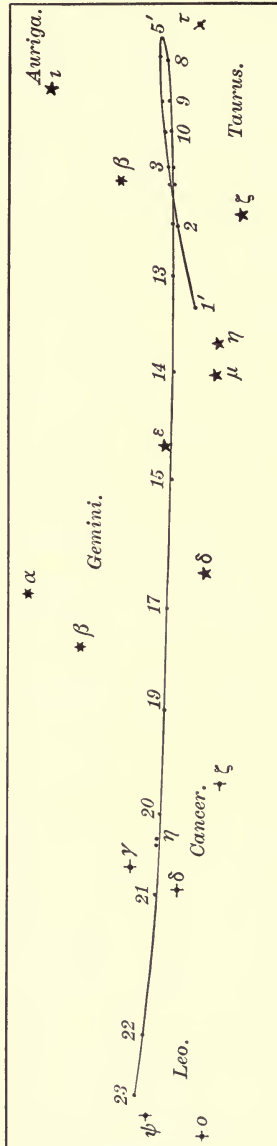

FIG. 24. — Path of Mars from Ephemeris, 1896-97.

gression, and to determine the motion in right ascension and declination between the stationary point and the last observation (5, 23). The numerical values thus derived and their checks are:

| Arc of Retrogression from | | Motion in R.A. | | Motion in Decl. | |
|---------------------------|--------|--------------------------------|--------------------------------|-----------------|--------|
| Obs. | Ephem. | Obs. | Ephem. | Obs. | Ephem. |
| 19°.0 | 18°.2 | 4 ^h 58 ^m | 4 ^h 57 ^m | - 9°.3 | - 9°.5 |

The minus sign signifies that the planet's declination was decreasing. (H. W. B.)

In Fig. 24 (see preceding page) we have the path of Mars traced by taking the coördinates from the Ephemeris for Greenwich noon. The same numbers in the two figures indicate that corresponding positions were fixed on the same dates, except where they are marked by primes, as 1' and 5', Fig. 24. These points were taken to correspond exactly with the planet's place when it began to retrograde and then advance again. They agree closely in date with 1 and 5 in Fig. 23.

A comparison of the two paths shows perhaps as close an agreement as ought to be expected from the method employed. The centre of the arc of retrogression in the observed path corresponds, as it should, very nearly with the date of opposition (Young, Art. 495, E. Art. 290); that is, position 3, Fig. 23, was located on December 10, and the opposition of Mars came a few hours later at midnight.

172. Path of Jupiter among the stars. — From January 7 to June 23, 1897, Jupiter's position with regard to the stars was determined by 12 small maps or diagrams. In tracing the path (Fig. 25), the same method was employed as described for Mars in the preceding section.

The dates of the important positions are as follows:

- | | |
|------------------|--------------|
| 1. Jan. 7, 1897. | 8. Apr. 21. |
| 3. Feb. 19. | 9. May 22. |
| 4. Feb. 24. | 10. June 11. |
| 5. March 10. | 12. June 23. |

From this list and from the figure, we see that points 3 and 4 were near the centre of the arc of retrogression, and were obtained about the time of Jupiter's opposition, which came February 23. These points mark quite accurately the centre

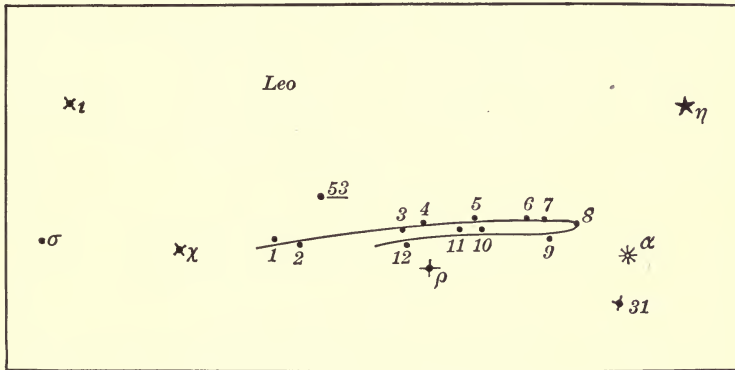

FIG. 25. — Path of Jupiter from Observation, 1898.

of the arc when tested by the theoretical path, although Jupiter began to retrograde some days before the first observation was taken.

The arc of retrogression and the change in coördinates during the last two months are :

| Arc of Retrogression from | | Motion in R.A. | | Motion in Decl. | |
|---------------------------|--------|-----------------|-----------------|-----------------|--------|
| Obs. | Ephem. | Obs. | Ephem. | Obs. | Ephem. |
| 10°.6 | 10°.9 | 19 ^m | 18 ^m | - 2°.2 | - 1°.8 |

A glance at corresponding values for Mars shows that Jupiter in comparison was moving very slowly. Indeed, from Figs. 23 and 25 we find that while Mars was passing from Taurus through Gemini and Cancer into Leo, Jupiter traversed less than half of the latter constellation.

(H. W. B.)

173. Satellites of Jupiter. — S. C. O., Friday, May 13, 1898. Between nine and ten this evening I examined Jupiter with my opera-glasses, which magnify two diameters. Close to the

planet, indeed almost in contact with it, two points of light were distinguished. The one on the right appeared whenever I looked, but that on the other side seemed to come and go from time to time. (L. B.)

Another observer making an independent examination with the same glasses reached the same conclusions; and reference to the Ephemeris after both observations were finished (§ 2) showed that satellites 1, 2, and 3 were at the time near together on the right, so they would naturally appear as one bright object, while 4 was alone on the other side.

174. Right ascension and declination of Saturn.— S. C. O., Friday, May 13, 1898. The right ascension and declination of Saturn were determined to-night in three different ways: by direct estimate from the equinox, by measures made with the cross-staff, and by a diagram of the planet with neighboring stars.

As a preliminary step for the first method, the autumnal equinox was located by η and β Virginis. The star ζ Virginis fixed another point in the celestial equator, which was then prolonged farther to the east by stars in Serpens and Ophiuchus. From the equator thus traced a perpendicular was dropped to Saturn, and its length called equal to the star-line δ Ophiuchi δ Scorpii. The distance from the foot of the perpendicular to the equinox was estimated to be $3\frac{1}{4}$ (α Libræ α Virginis).

These measures, expressed in degrees and hours, give directly the planet's south declination and its right ascension east of the autumnal equinox. The required coördinates are, therefore, declination $-19^{\circ}.4$ and right ascension $16^{\text{h}} 34^{\text{m}}$.

To fix the place of Saturn by means of the cross-staff, three reference stars were chosen, α Libræ, and η and ζ Ophiuchi. The first observation was taken thus. The eye was brought to the sight near the eye end of the cross-staff, and the cross-piece shifted back and forth till light from α Libræ and from the

planet reached the eye through the eight-inch sights. Three pointings were made, and the mean of the readings at the edge of the cross-piece was 15.41 inches. In like manner the five-inch sights were employed in finding similar data from the other stars.

Now, when the cross-staff is used in this manner, it is clear that lines from the sights at the object end form at the eye the required angle between the two bodies. Thus, in Fig. 26, if S and P are the sights, the eye at B should see one body in the direction BS and the other in the direction BP , making the angular distance between them SBP . Half this angle, CBP , is readily determined; for the triangle BCP is right-angled at C , CP is half the distance between the sights, and CB is obtained from the observation, corrected if necessary for the position of the sights on the cross-piece, and the place of the eye in regard to the sight near it.

For the first observation we have, then,

$$\tan CBP = \frac{3.98}{16.47} \text{ and } CBP = 13^{\circ}.6,$$

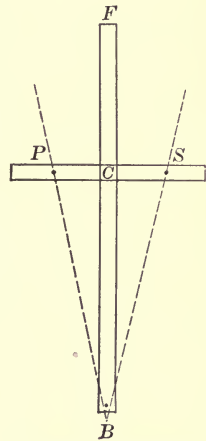

FIG. 26. — Cross-staff.

which makes the distance between Saturn and α Libræ $27^{\circ}.2$. This angle, combined with those determined in like manner for η and ζ Ophiuchi, gave data for placing the planet on the celestial globe. Its coördinates were then measured as usual.

Trigonometry is not necessarily required in reducing an observation made with the cross-staff. The angle between the sights can be marked off on paper and then read from the circular protractor (§ 100).

According to the third method, right ascension and declination were read from a star-map after Saturn's position had been fixed by a diagram made directly from the sky (§ 167).

The results obtained by the different methods between ten and twelve o'clock P.M. are as follows :

| | Estimates. | Cross-staff. | Diagram. | Ephemeris. | Observer. |
|-------|---------------------------------|---------------------------------|------------------------------------|------------------------------------|-----------|
| R.A. | 16 ^h 34 ^m | 16 ^h 37 ^m | 16 ^h 34 ^m .0 | 16 ^h 35 ^m .4 | L. C. H. |
| Decl. | - 19°.4 | - 20°.6 | - 20°.0 | - 20°.1 | " |

175. Uranus identified. — In brightness Uranus is ranked as a star of the sixth magnitude. If, then, the planet is well placed above the horizon, and the conditions for seeing are favorable, it can be identified with the help of the Ephemeris and a good star-map. Inexperienced observers are, however, so likely to mistake a star for the planet, that it is best, if possible, to use an opera-glass, and watch the small objects near the Ephemeris place of Uranus till one of them is clearly proved to be in motion.

OBSERVATION 1. — S. C. O., Friday, May 13, 1898. On this date, according to the Ephemeris and Proctor's Atlas, Uranus should be very near the ω 's in Scorpio. Examining the neighborhood of these stars, I found a small object close to ω^1 which was not as bright as ω^2 . It was called p , and the following estimates recorded :

$$p \omega^1 = 1\frac{1}{2} (\omega^1 \omega^2)$$

$$\angle p \omega^1 \omega^2 = 90^\circ + 35^\circ$$

OBSERVATION 2. — S. C. O., Saturday, May 21, 1898. The first glance showed that the object p had moved since May 13. Its new position was given by the equations

$$p \omega^1 = 2\frac{1}{2} (\omega^1 \omega^2)$$

$$\angle p \omega^1 \omega^2 = 90^\circ + 50^\circ$$

Since the two observations prove that the small body had changed its distance and direction from ω^1 Scorpii, it was without doubt the planet Uranus. (R. G. W.)

176. Time from an altitude of Mercury. — S. C. O., Saturday, Apr. 17, 1897. Four measures of the altitude of Mercury

were taken this evening with Circles No. 3, two with the vertical circle facing south, and two with it facing north (§ 113, Obs. 3). Applying a correction for refraction to the mean altitude $5^{\circ} 34'.5$, I find that Mercury's zenith distance was $84^{\circ} 34'.5$, when the watch time was $7^h 28^m 9^s$ P.M. (A. E. T.)

The planet's zenith distance and its declination give data for computing the hour-angle by Formula (6), Section 40. Knowing the hour-angle, we find sidereal time (§ 39), mean time (§ 53), and the error of the watch as follows:

| | | | |
|-------------------------|-----------------------------|---------------------|-----------------------|
| Hour-angle | = $6^h 36^m 34^s$ | | |
| Right ascension | = $2 \ 45 \ 47$ | | |
| Sidereal T. | = $9 \ 22 \ 21$ | Sidereal T. | = $9^h 22^m 21^s$ |
| | $V_0 = 1 \ 43 \ 30$ | | $V_0' = 22 \ 16 \ 47$ |
| | $\odot - V_0 = 7 \ 38 \ 51$ | Corr. for \odot | = $-1 \ 32$ |
| Corr. for $\odot - V_0$ | = $-1 \ 15$ | Corr. for λ | = $- \ 48$ |
| Corr. for λ | = $- \ 48$ | Mean local T. | = $7 \ 36 \ 48$ |
| Mean local T. | = $7 \ 36 \ 48$ | | |
| Stand. T. fr. Obs. | = $7 \ 27 \ 21$ | | |
| Watch T. of Obs. | = $7 \ 28 \ 9$ | | |
| Error of watch fr. Obs. | = $- \ 48$ | | |

Since the watch was in reality only 8^s fast, the error of the observation was 40^s .

177. Time from an altitude and azimuth of Jupiter.—S. C. O., Saturday, May 29, 1897. An observation of Jupiter, similar to that of the sun already described (§ 113), was made with the Circles, and the following means obtained:

| Watch Time. | Altitude. | Azimuth. | Observer. |
|-----------------|--------------------|-------------------|-----------|
| $9^h 16^m 48^s$ | $34^{\circ} 34'.5$ | $75^{\circ} 1'.5$ | M. B. |

As usual, we find the time required by ascertaining the error of the watch. Jupiter's hour-angle having been calcu-

lated by Formula (5), Section 40, the work may be arranged thus:

| | |
|--------------------------|--|
| Hour-angle | = 3 ^h 38 ^m 56 ^s |
| Right ascension | = <u>10 17 16</u> |
| Sidereal time | = <u>13 56 12</u> |
| Mean local time. | = <u>9 24 46</u> |
| Stand. time from Obs. | = 9 15 19 |
| Watch time of Obs. | = <u>9 16 48</u> |
| Error of watch from Obs. | = - 1 29 |

If the watch time of the observation is corrected for the true error of the watch, we have in this example 9^h 16^m 8^s P.M. as the true standard time of the observation; but since the time derived from measures of altitude and azimuth was 9^h 15^m 19^s, the observation was in error 49^s.

178. The Leonids in 1898.— On the morning of November 15, about an hour after midnight, I saw that meteors were falling more frequently than usual. From this time until three o'clock I kept watch from an east window of the Dickinson House, Smith College. From this window the portion of the sky visible included nearly 25° in every direction about the radiant of the Leonids.

According to the suggestion sent out from Harvard College Observatory, counts of ten meteors were made, separated by about half an hour. Between 1^h 32^m A.M. and 1^h 44^m A.M. ten were counted, and another ten from 2^h 9^m to 2^h 19^m.

The whole number of meteors seen was about fifty, and of these, all except five or six appeared to be Leonids. Most of them were greenish in color, though some were white, and a few yellow. They were swift in motion, remaining in sight only a second or two, and being followed by trains which lasted about as long.

At 1^h 51^m a very bright Leonid was seen to shoot from δ Leonis, and to burst at a distance $\frac{4}{5}$ ($\delta\gamma$) from δ . It was yellow

with a tinge of red, moved rather slowly, and left a train which lasted several seconds. Though not as bright as Sirius, it was clearly brighter than Vega. (L. B.)

Students who are interested in observations of m \acute{e} teors will find many helpful suggestions in articles which have been contributed by W. F. Denning to the *Observatory* and other astronomical journals.

CHAPTER VIII.

STARS AND MILKY WAY.

STARS are preëminently the objects to be employed by all observers in finding latitude and time. If any others are chosen, it is often necessary to wait for favorable times and positions; but on any clear evening the stars give so large a range of choice that several independent determinations are easily made in a short interval of time.

The stars known as variables are especially interesting to beginners, as they afford one of the few subjects which are open to them for original investigation.

Most of the questions which follow assume a general acquaintance with the constellations. None are included which cannot be answered from observation, or by data obtained from observation. As usual, eastern standard time is employed, if some other time is not mentioned or indicated in the text.

QUESTIONS.

179. Points and circles determined by stars.

1. If the North Star is taken to mark the north pole of the heavens, how is the pole placed with regard to zenith and horizon?
2. How do the cardinal points determined directly from the North Star differ from those fixed by the Circles?
3. How accurately are the cardinal points determined with the help of the celestial globe?
4. What is the error of a north and south line located by the North Star?
5. On a given date what stars are taken to trace the path of the celestial equator?
6. How near the zenith does the celestial equator pass at a given hour? At what points does it intersect the horizon?

7. Does it remain fixed with regard to the horizon of a given place from week to week? From month to month?

8. By what stars is the ecliptic traced?

9. On a given night what is its meridian altitude and at what points does it intersect the horizon?

10. During two or three hours, what changes are noted in its position with regard to the horizon?

11. What changes are noted if two observations are made at the same hour of the evening, but in different months of the year?

12. What are the meridian altitudes of the ecliptic determined in the daytime by the sun, and by a star on the following night?

13. What stars are employed in fixing the position of the vernal equinox? The autumnal equinox?

180. Rising and setting.

1. When and where does a star rise, at a given place, if its declination is about 10° north of the equator?

2. When two stars are on the same hour-circle, how do their times of rising compare, if one is 20° north and the other 20° south of the equator?

3. Can a star be found rising at the east point of the horizon?

4. What is the greatest angular distance north or south of the east point at which a star is seen to rise?

5. At what intervening points is the rising of stars noted?

6. At what points along the western horizon are stars found to set?

181. Visibility.

1. Can a bright star be followed at the place of observation till it sets, that is, till it actually reaches a distant horizon line?

2. If a star is of the third or fourth magnitude, at what height above the horizon does it disappear?

3. When, if ever, have you seen a star in the evening before sunset?

4. On a clear evening what star is seen first after sunset? How soon is it visible?

5. How long is it after sunset before sixth magnitude stars are visible? Does the presence of the moon affect the time?

6. As seen with an opera-glass, what is the difference in the appearance of a star that is well up toward the zenith and one that is about to set?

7. Does the transit tube affect the appearance of a star?

182. Coördinates.

1. On a given night what is the altitude and azimuth of a star south of the zenith?

2. How much do these coördinates vary if observations are separated by an hour?

3. Under what conditions is altitude found to change rapidly and azimuth slowly?

4. If observations are made at one place on nights a week or two apart, does a particular star have the same azimuth at setting? Is the time of setting the same?

5. Is any variation found in the meridian altitude of the same star?

6. From altitude and azimuth observed with the Circles, what values are found by calculation for right ascension and declination?

7. What is the estimated right ascension and declination of a given star?

8. What is the estimated latitude and longitude of a given star?

9. If observations of a particular star are separated by several weeks, is any change detected in its right ascension and declination?

183. Apparent motion.

1. If the diurnal path of a star has been located by making a number of measures of its altitude and azimuth, is any change noted in the path a month or two later?

2. What is a star's hourly rate of motion in the diurnal path?

3. Having fixed the position of the "great dipper" with regard to the horizon, do you find after an hour or two that it has moved toward the eastern or toward the western horizon? Are like results obtained if observations are made at about the same evening hour in October and in April?

4. What easier method than sitting up all night and watching with a telescope all day can you devise for determining the complete motion of the great dipper?

5. What stars on a given night are found moving toward the eastern horizon?

6. In general, toward what part of the horizon are stars moving?

7. By making careful maps of a particular constellation at different times, is it possible to detect any motion of the stars with regard to one another?

8. Judging from your own observations, under what general statement is it possible to include the apparent motion of all stars in different parts of the sky?

184. Latitude.

1. What value for the latitude of the place of observation is obtained from a meridian altitude of the North Star?

2. What is the latitude derived from an altitude of this star when not on the meridian?

3. How can latitude be found by observing a star whose declination is zero?

4. What value for latitude is obtained by finding the meridian altitude of a star of any declination?

5. How can the altitudes of two stars on opposite sides of the zenith be utilized in finding latitude?

185. Time.

1. What is the hour-angle of a circumpolar star when the line connecting it with the North Star appears to be parallel to the horizon?

2. How accurately can you tell sidereal time from β Cassiopeiæ?

3. What is the error of a common watch determined from the altitude and azimuth of a star measured with the Circles?

4. If the altitude only is measured, what error is found?

5. If two plumb lines are taken to fix the meridian, how accurately is the watch error found from the transit of a star?

6. As determined by two transits of a star, what is the difference in the length of the sidereal and of the mean solar day?

186. Color and brightness.

1. From your own observation, what color do you assign to each of the following stars?

- | | |
|-----------------------------|---------------------------------|
| (1) α Aquilæ. | (11) β Orionis. |
| (2) α Aurigæ. | (12) γ Orionis. |
| (3) α Boötis. | (13) α Persei. |
| (4) α Canis Majoris. | (14) α Piscis Australis. |
| (5) α Canis Minoris. | (15) α Scorpii. |
| (6) α Geminorum. | (16) α Tauri. |
| (7) β Geminorum. | (17) β Tauri. |
| (8) α Leonis. | (18) α Ursæ Majoris. |
| (9) α Lyræ. | (19) β Ursæ Majoris. |
| (10) α Orionis. | (20) α Virginis. |

2. From among the stars of this list which are visible on any particular night, what pairs can be selected in which the two stars are nearly equal in brightness? What pairs where there is a marked contrast in brightness?

3. What pairs can be selected in which the two stars are alike in color? What pairs in which there is a marked contrast in color?

4. Which is the brighter, α or β Leonis? α or β Geminorum?

5. What is the brightest star seen during the year?

6. Among the stars visible in different seasons which do you rank second in brightness? Which third?

7. When brightest how does Algol compare with α Persei?

8. On the evening of a minimum, when is Algol found equal in brightness to β Persei? When equal to η , and when to γ Persei?

9. As σ Ceti approaches a maximum when is the star first visible with an opera-glass? When first visible to the naked eye?

10. When does the star reach a maximum in brightness?

187. Double stars, clusters, and nebulæ.

1. Can you see ζ Ursæ Majoris double with the naked eye?

2. How does it look through an opera-glass?

3. In the following list of stars can you distinguish more than one with the naked eye? With the opera-glass?

| | |
|----------------------------|--------------------------|
| (1) 15 Canis Venaticorum. | (11) ϵ Orionis. |
| (2) α Capricorni. | (12) θ Orionis. |
| (3) β Capricorni. | (13) ι Orionis. |
| (4) ν Cassiopeia. | (14) π Pegasi. |
| (5) ν Coronæ Borealis. | (15) μ Scorpii. |
| (6) σ Cygni. | (16) ω Scorpii. |
| (7) ζ Leonis. | (17) θ Tauri. |
| (8) α Libræ. | (18) κ Tauri. |
| (9) δ Lyræ. | (19) σ Tauri. |
| (10) ϵ Lyræ. | (20) 80 Tauri. |

4. Can you see the nebula of Andromeda with the naked eye?

5. How does it look through an opera-glass?

6. How many stars can you see in the cluster of the Pleiades with the naked eye? What is the number counted with an opera-glass?

7. How many of the following star-clusters and nebulae are seen with the naked eye? How does an opera-glass change their appearance? *

- (1) Coma Berenicis.
- (2) Præsepe in Cancer.
- (3) Nebula in Orion.
- (4) H. VI, 33, 34, near η Persei.
- (5) H. VII, 2, in Monoceros, R. A. $6^h 27^m$, $\delta + 4^\circ.9$.
- (6) H. VIII, 72, not far from β Ophiuchi.
- (7) M. 8, not far from λ Sagittarii.
- (8) M. 13, between η and ζ Herculis.
- (9) M. 34, not far from β Persei.
- (10) M. 35, near η Geminorum.
- (11) M. 39, near ρ Cygni.
- (12) M. 41, near α Canis Majoris.

* All the objects given in the list are marked on the maps of Young's Uranography, except (5), which may be found in Proctor's or Shurig's Atlas near the star 12. Clusters (4) and (6) are designated simply by Cl. on Young's maps.

188. Form and diameter of the Milky Way.

1. Is the arch of the Milky Way a part of a great circle or a part of a small circle?
2. At any particular point what is its diameter in degrees?
3. What are the greatest and least diameters noted?
4. At what point does a branch extend from the main arch? What is its length and diameter?

189. Varying brightness.

1. How early in the evening and in what part of the sky does the first trace of the Milky Way appear?
2. At what hour is the whole arch seen as distinctly as artificial lights permit?
3. Where is the arch of light especially bright? Where is it pale?
4. What stars in Cassiopeia, if connected, bound an especially bright spot in the Milky Way?
5. What stars connected bound a dark rift in Cepheus? What ones in Cygnus?

190. Apparent motion.

1. In the latter part of September, about nine o'clock in the evening, how is the arch of the Milky Way placed with regard to the zenith?
2. What is the azimuth of each point at which it intersects the horizon?
3. How is it placed with regard to zenith and horizon about nine o'clock on an evening in January, in April, and in June?
4. What change is noted in the points of intersection after an interval of a month? What change in the highest point of the arch?
5. If observations instead of being taken a month apart are separated by two hours on the same evening, how does the position of the Milky Way change?
6. Do the stars of the Milky Way move with it or are they left behind?

SUGGESTIONS AND ILLUSTRATIONS.

191. Cardinal points. — Before permanent lines of reference are established (see Chapter II) it is well to fix the cardinal points approximately with the help of the North Star. A clear evening should be chosen, and an hour when twilight or moonlight renders objects on the horizon easily visible. If, then, we face toward the North Star, and mark out its vertical circle by sweeping downward from the zenith through the star, the intersection of this circle with the horizon locates the north point.

To fix the south point, the right hand may be directed to the point just determined, and both arms extended to form a straight line. This line of direction prolonged to the horizon on the left marks the south point. The east and west points may be located in a similar manner by facing north. After such tests have been repeated several times, the places of the points should be fixed by permanent objects on the horizon.

More accurate positions for the cardinal points are found by means of the celestial globe. Suppose, for example, that we wish to fix the east point of the horizon, the globe should be turned till a line drawn through any two bright stars at low altitude meets the horizon at the required point. The sidereal time for tracing this line in the sky is given by the corresponding right ascension of the meridian, from which any desired time is readily derived (§ 53).

OBSERVATION. — S. C. O., Friday, Apr. 8, 1898. When the globe was oriented for 8^h 15^m P.M., α Boötis was about 30° high, and a line drawn down from this star through ζ Boötis met the horizon almost exactly at the east point. For the same position of the globe, the line joining α and β Tauri intersected the horizon in the west point. At a quarter after eight these points were located by prolonging the star-lines with the unaided eye to the plane of the horizon. Later the azimuth of each point

was measured by the Circles, giving an error of 2° for one and 1° for the other.

192. Constellations.—Astronomers may ignore the constellations entirely, but elementary students will find it helpful as well as pleasant to become familiar with them. It is well for such students to form the habit of watching the heavens regularly from month to month, so as to find out in what paths the bright constellations cross the sky, and to connect, if possible, their rising and setting with permanent landmarks on the horizon, and with particular months in the year.

When an individual constellation is taken up for detailed examination, it is important to identify the bright stars from sky to map, to make sketches with proper symbols for different magnitudes, and to fix in mind a definite configuration. Thus we may think of Lyra as a parallelogram and triangle combined with a few outlying points.

LYRA TRACED.—Florence, Mass., 110 Pine Street, Thursday, July 1, 1897. In spite of shifting clouds, the principal stars of Lyra were visible between ten and eleven in the evening. Nearly an equilateral triangle is formed by α , ϵ , and ζ , and the latter with β , γ , and δ makes a fair-shaped parallelogram.

All estimates of line and angle depended finally upon a right angle and the line $\alpha\zeta$, except that the space between the components of ζ Ursæ Majoris (Mizar Alcor) was used in making a slight correction.

The six stars of the triangle and parallelogram are plotted from the following relations (§ 144):

$$\begin{array}{ll} \epsilon \zeta \beta = \text{straight line} & \zeta \beta = 2\frac{1}{4} (\alpha \zeta) \\ \angle \beta \zeta \delta = 60^\circ & \alpha \zeta = \epsilon \zeta = \zeta \delta - (\text{Mizar Alcor}) \\ \angle \alpha \zeta \epsilon = 45^\circ & \alpha \epsilon = \alpha \zeta - 2 (\text{Mizar Alcor}) \end{array}$$

If the line $\gamma\delta$ is prolonged to the left, and a perpendicular dropped upon it from α , η is found at the extremity of the latter

line, if its length below $\gamma\delta$ is made equal to that above it. The intersection of $\delta\zeta$ and $\eta\gamma$ fixes the place of ι approximately, and the other stars included in Fig. 27 are obtained by similar devices. The symbols for magnitude are similar to those employed in Young's Uranography. (H. R. C.)

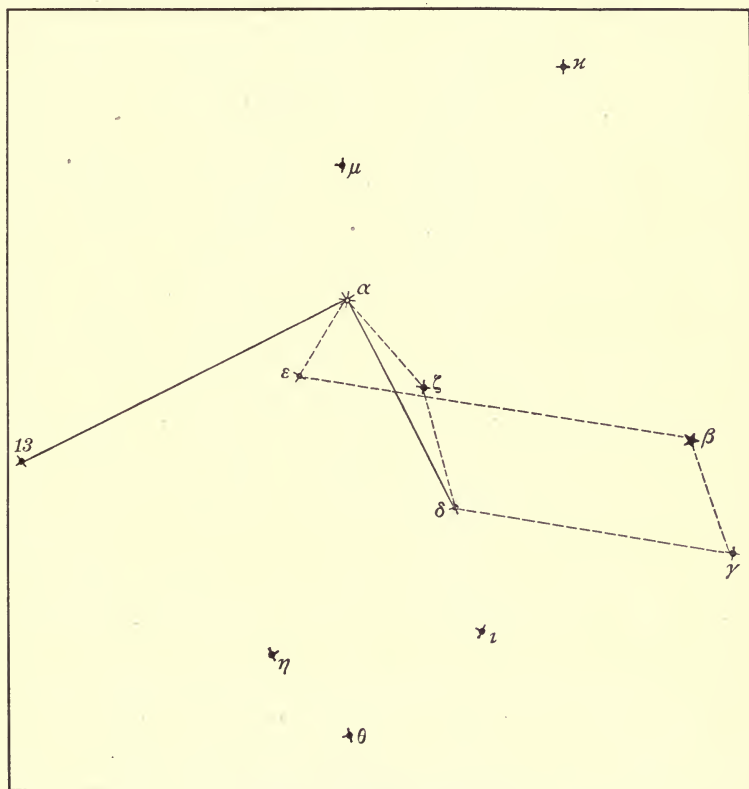

FIG. 27.— Constellation Lyra.

193. Motion of the "great dipper."— Motion with regard to the horizon is best determined when the altitude of heavenly bodies is small, so that changing positions can be referred directly to the natural horizon of hills and trees. If the celestial object

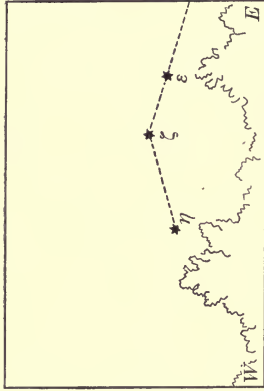

FIG. 29. — 9h 15m P.M.

POSITIONS OF GREAT DIPPER, OCT. 18, 1895.

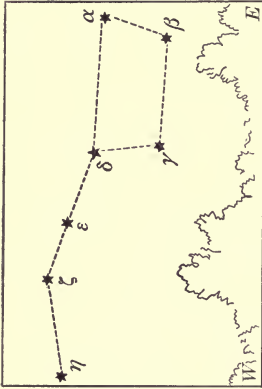

FIG. 28. — 7h 15m P.M.

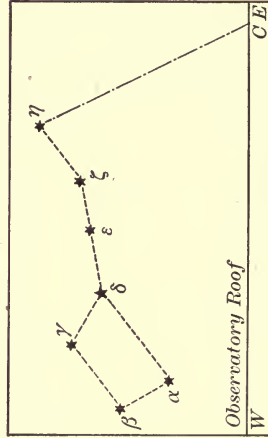

FIG. 31. — 9h 40m P.M.

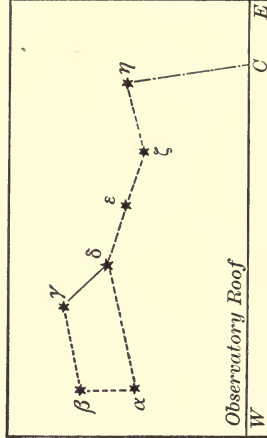

FIG. 30. — 8h 20m P.M.

POSITIONS OF GREAT DIPPER, MAY 7, 1896.

is at a high altitude, it may still be brought near an artificial horizon by making observations close to a building, so that its walls and roof serve as reference lines.

In order to ascertain toward what quarter of the horizon the great dipper was moving on the evening of Oct. 18, 1895, the configuration was sketched twice with regard to the same horizon line at Northampton, Mass.

The first position is given in Fig. 28. Two hours later the dipper had moved so far downward and eastward that only the three stars of the handle were visible, as shown in Fig. 29.

About six months after these observations, May 7, 1896, the dipper was drawn again at the same place by the same observer, but on this date the roof of the observatory served as the horizon, and since it was so near, special care was taken to stand each time in exactly the same place, close to the west end of the top step of the building.

The positions determined are given in Figs. 30 and 31, where *C* marks in each the same fixed point on the roof near the east corner of the building.

Although the interval between the two sketches is less than an hour and a half, there is no doubt about the westward motion of the dipper.

In these figures, for the two sets of observations, the letters *E* and *W* indicate the direction of east and west. (A. E. G.)

194. Diurnal motion of the ecliptic.—The imaginary circles of reference on the celestial sphere may be traced at night by means of the stars. The stars also enable us to locate these circles with regard to our own zenith and horizon. Thus, in order to find the meridian altitude of the ecliptic, we can measure the altitude of a star on the ecliptic when it reaches the meridian. If at the same instant two bright stars happen to be at the points where the ecliptic meets the horizon, their azimuths fix these intersections, and the path of the ecliptic above

the horizon is well determined for the particular time. Of course such ideal conditions are rarely if ever realized, and moreover most observers must content themselves with poor horizon lines.

On July 17, 1896, observations were made with the Circles at Smith College Observatory to fix the position of the ecliptic with reference to the horizon.

On that date Saturn was only $2^{\circ}.0$ above the ecliptic, and between eleven and twelve in the evening was situated low in the southwest. As the planet approached its setting point, ζ Sagittarii, a star not far from the ecliptic was near the meridian, and the constellations Triangulum and Aries were visible in the east a little above the Wallace House (§ 107).

Reference to Young's Uranography showed that a line drawn through α Trianguli and α Arietis would intersect the ecliptic if prolonged beyond the latter star a little farther than the distance between the two α 's. When the line thus described practically met the horizon, the azimuths of the point located and of the planet at setting were taken to mark the approximate intersections of the ecliptic with the horizon. Its meridian altitude was found by adding to the observed altitude of ζ Sagittarii, the star's distance below the ecliptic measured along its hour-circle on a star-map.

The results obtained before midnight, July 17, 1896, are as follows:

| | | |
|-------------------------------|----------------|-------------------------------|
| Azimuth of S.W. intersection, | 69° , | $11^{\text{h}} 33^{\text{m}}$ |
| Azimuth of N.E. intersection, | 249 , | $11 39$ |
| Altitude on the meridian, | 26 , | $11 50$ |

When this position was fixed, the meridian altitude of the ecliptic was nearly as great as any altitude throughout its course from Libra to Aries. But two hours later, when δ Capricorni was on the meridian, the path of the ecliptic lay higher toward the east than directly in the south. The zodiacal constellations on the horizon at that time were Sagittarius and Taurus, and

by their aid the points where the ecliptic met the horizon were located in a manner similar to that just described.

Owing to the difficulty of determining and observing three points at about the same time, the meridian altitude was fixed two hours later than the first observation, but the points of intersections three hours later.

The angles measured after midnight on the morning of July 18 are:

| | | |
|-------------------------------|------|--------------------------------|
| Azimuth of S.W. intersection, | 56°, | 2 ^h 34 ^m |
| Azimuth of N.E. intersection, | 240, | 2 27 |
| Altitude on the meridian, | 36, | 1 50 |

The altitude given here was obtained from δ Capricorni, just as the altitude above was derived from 52 Sagittarii.

A comparison of these two observations shows that on the given night the meridian altitude of the ecliptic was increasing, and both intersections were moving eastward along the horizon (§ 7). The hourly rate of motion in altitude was $5^{\circ}.0$, and in azimuth $3^{\circ}.8$ as against $3^{\circ}.5$ and $4^{\circ}.3$ derived from the globe (Table XIV). The mean of the two angular distances between the points of intersection, 182° , indicates that the ecliptic is approximately a great circle.

A month later, at the same place, the ecliptic was traced by the same stars employed in fixing its position on the morning of July 18. Between the two dates care was taken not to look at the numbers recorded in July, so in August there was no predisposition in favor of any particular values (§ 2).

The results derived from these three observations and their checks obtained from the celestial globe are brought together in Table XIV. The astronomical day is employed, and the mean of the times entered in connection with the two azimuths for each position; for they differed by only six or seven minutes, and any change in half that interval is small compared with the errors likely to occur in such observations.

The checks given in the table were read as usual from the

globe, oriented for the times in the first and sixth columns. The bracketed values for altitude are those of the sun obtained from observation and from the globe at noon, July 18.

By comparing the July and August observations we see that practically the same change takes place in the meridian altitude of the ecliptic between observations on the same evening, separated by two hours, and those taken at the same hour, but separated by a month. In like manner the azimuths read

TABLE XIV. — POSITIONS OF THE ECLIPTIC IN JULY AND AUGUST, 1896, AT NORTHAMPTON, MASS.

| TIME. | S.W. INTERSECTION. | | N.E. INTERSECTION. | | TIME. | MERID. ALT. | |
|---------------------------------|--------------------|--------|--------------------|--------|---------------------------------|-------------|---------|
| | OBS. | GLOBE. | OBS. | GLOBE. | | OBS. | GLOBE. |
| July 17 | | | | | July 17 | | |
| 11 ^h 36 ^m | 69° | 70° | 249° | 250° | 11 ^h 50 ^m | 26° | 26° |
| 14 30 | 56 | 57 | 240 | 238 | 13 50 | 36 | 33 |
| | | | | | [July 18, 0 ^h] | [68 .5] | [68 .6] |
| Aug. 17 | | | | | Aug. 17 | | |
| 12 ^h 27 ^m | 57 | 57 | 242 | 238 | 11 ^h 53 ^m | 34 | 34 |

in the second July observation agree with those obtained on the August date, a month later, but two hours earlier in the evening.

The sun's position at any time fixes a point on the ecliptic, since by definition this circle is described by the annual motion of the sun. Hence the sun's altitude at noon is the same as the meridian altitude of the ecliptic, and we see from the table that between midnight, July 17, and the following noon, the meridian altitude of the ecliptic increased 42°.

In finding the motion of the ecliptic any appliance may be used for measuring angles, or altitude and azimuth may be estimated directly as in Section 208.

195. Latitude from the altitude of stars. — The altitude of a known star when on the meridian may be employed in the same manner as the sun's noon altitude in finding the latitude of a place (§ 114).

OBSERVATION 1. — S. C. O., Friday, Nov. 13, 1896. When the azimuth of Fomalhaut was practically zero, three measures of its altitude were made with the Circles, and the mean value obtained, corrected for refraction, was $17^{\circ} 42'$. (A. B. R.)

If to this altitude we add the star's angular distance below the equator measured on the meridian, that is, its south declination, $30^{\circ} 10'$, the sum $47^{\circ} 52'$ is the meridian altitude of the celestial equator. But the complement of the equator's meridian altitude is the declination of the zenith, or the latitude of the place (§ 32). According, then, to this observation the latitude of the place is $42^{\circ} 8'$.

Since the altitude of the north pole of the heavens equals the latitude of the place, meridian altitudes of Polaris enable us to find latitude.

OBSERVATION 2. — S. C. O., Tuesday, Dec. 1, 1896. The Circles No. 1 were placed and adjusted on the first meridian stone on the south, and three readings made of the meridian altitude of the Pole Star, giving a mean value, $43^{\circ} 30'$, at $8^{\text{h}} 29^{\text{m}}$ P.M. (L. H. W.)

The observed altitude corrected for refraction is $43^{\circ} 29'$, and this would be the latitude required if the Pole Star were at the pole of the heavens; but since its declination is a little less than 90° , it describes a small circle about the pole. In order to find the altitude of the pole from that of the star, the observed value must therefore be decreased or increased by $(90^{\circ} - \delta)$, according as the transit is above or below the pole.

From the time given on December 1 it is evident that the observation was taken at upper transit, so we subtract $(90^{\circ} - 88^{\circ} 46')$, that is, $1^{\circ} 14'$, from the measured altitude, $43^{\circ} 29'$, and obtain $42^{\circ} 15'$ for the latitude.

By means of Table IV, given on the last page of the American Ephemeris, latitude may be derived from any altitude of the North Star, provided the time is known.

OBSERVATION 3. — S. C. O., Monday, June 28, 1897. At 10^h 12^m P.M. the altitude of Polaris determined with Circles No. 3 was found to be 41° 56', or 41° 55' when corrected for refraction. (A. E. T.)

The sidereal time corresponding to 10^h 12^m is 16^h 51^m, which, subtracted from 25^h 21^m (see Ephemeris), gives the hour-angle 8^h 30^m. With this hour-angle we take out from Table IV the correction + 46', which makes the latitude 42° 41'.

Although these three observations of latitude have been taken as illustrations without any consideration of how they would combine, their mean value is found to be 42° 21', that is, within 2 minutes of the true latitude of the place.

196. Measuring circle for estimating hour-angles. — As an aid in determining directly the hour-angle of a circumpolar star, we

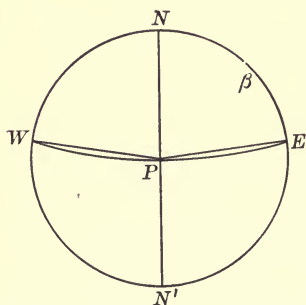

FIG. 32. — Hour-angle of β Cassiopeiæ.

may take the star's north polar distance as a radius, and describe an imaginary circle about Polaris as a centre. The vertical circle passed through Polaris marks out the meridian and bisects this circle.

Now, as we look to the north in the evening, we see that the halves of this circle are divided roughly into quarters by drawing through the North Star a line parallel to the horizon.

In Fig. 32, let W and E be the two points where this parallel line meets the measuring circle. It is evident that the small circle WPE , being a parallel of altitude, is perpendicular to the meridian, but it by no means follows that NW and NE are arcs of 90°. As a preliminary

step it is therefore necessary to ascertain the value of one of these equal arcs, or, in other words, to find the hour-angle of a point on the measuring circle when it has the same altitude as the North Star.

Let us assume that the measuring circle is designed for β Cassiopeiæ. Since the north polar distance of this star is $31^{\circ}.4$, we pick out a star east or west of the meridian, about 30° from Polaris, and note the time when the line joining the two stars appears parallel to the horizon. The corresponding sidereal time minus the star's right ascension gives approximately the required hour-angle of the point W or E .

OBSERVATION. — S. C. O., Saturday, Nov. 27, 1897. Looking to the north between five and six in the evening, I saw that the line from Polaris to β Draconis was nearly parallel to the horizon. At intervals of a minute or two this imaginary line was examined and called parallel at $5^{\text{h}} 47^{\text{m}}$ P.M. The corresponding sidereal time, or the right ascension of the meridian, is $22^{\text{h}} 25^{\text{m}}$, the star's right ascension $17^{\text{h}} 28^{\text{m}}$, and hence its hour-angle is $4^{\text{h}} 57^{\text{m}}$ (§ 39).

This angle and its supplement, $7^{\text{h}} 3^{\text{m}}$, give approximate values for the arcs NW and $N'E$ (Fig. 32) in the measuring circle required for β Cassiopeiæ; but beside errors of observation others are involved; for β Draconis is not at the same distance from Polaris as β Cassiopeiæ, nor is the Pole Star at the pole (§ 195, Obs. 2).

To obtain more trustworthy values for these arcs, different stars were observed on different nights on both sides of the meridian, some nearer Polaris than β Cassiopeiæ, and some farther away. In this manner the mean value found for the small "quadrants" above the pole (NW , NE) was $5^{\text{h}} 8^{\text{m}}$, making the large "quadrants" below the pole ($N'W$, $N'E$) $6^{\text{h}} 52^{\text{m}}$.

In order to check these angles, the celestial globe was oriented for the latitude of Northampton, and turned till the altitude of β Cassiopeiæ just equalled that of the pole. The required

hour-angle read in this position was $5^{\text{h}} 2^{\text{m}}$. By trigonometry the value obtained is $5^{\text{h}} 1^{\text{m}}$.

As soon as the measuring circle for a given circumpolar star has been divided into four known parts, it is only necessary to locate the star in one of these small divisions in order to determine its hour-angle.

197. Time directly from β Cassiopeiæ. — If a star were exactly on the hour-circle passing through the vernal equinox, its hour-angle at any time would equal that of the vernal equinox, and give sidereal time directly. While no bright star fulfils this condition, β Cassiopeiæ has a right ascension of only four minutes, and is placed near the North Star where angular distances from the celestial meridian are easily estimated.

OBSERVATION. — S. C. O., Thursday, Dec. 2, 1897. With a radius equal to the north polar distance of β Cassiopeiæ, I traced in the sky the imaginary circle described in the preceding section. At the time of observation β was east of the meridian, at an angular distance estimated to be $\frac{7.5}{100}$ of the upper "quadrant" above the extremity of the parallel line.

Employing the values of the quadrants obtained in Section 196, we find that the hour-angle of β Cassiopeiæ was $12^{\text{h}} + 6^{\text{h}}.87 + (5^{\text{h}}.13 \times 0.75)$, or $22^{\text{h}} 43^{\text{m}}$. Since the right ascension of the star is 4^{m} , the hour-angle of the vernal equinox, or sidereal time, was $22^{\text{h}} 47^{\text{m}}$ (§ 39). The time obtained independently was $22^{\text{h}} 43^{\text{m}}$, making the error 4^{m} . Two determinations made on another evening were in error 9^{m} and 13^{m} .

Sidereal time derived from β Cassiopeiæ may be reduced approximately to mean time by data given in a common almanac, if we bear in mind a few fundamental relations between different kinds of time.

EXAMPLE. — What is the mean time corresponding to the sidereal time $22^{\text{h}} 47^{\text{m}}$, Dec. 2, 1897, at Northampton, Mass.?

Since sidereal time gains about 4^{m} a day on mean time, in

order to find the difference between these times for any date, it is only necessary to know how they differ at any given epoch.

At the vernal equinox sidereal and apparent solar time agree, and at the autumnal equinox they differ by 12^h . The corresponding differences between sidereal and mean time are found by taking account of the equation of time. Thus, on Sept. 22, 1897, the mean sun was 8^m slow compared with the true sun (Jayne's Almanac). Hence on that date sidereal time was $12^h 8^m$ ahead of mean solar time.

The gain of sidereal time during the interval between September 22 and December 2, the date of the observation, was $4^m \times 71$, or $4^h 44^m$. So on this date the entire difference between sidereal and mean solar time was $12^h 8^m + 4^h 44^m$, or $16^h 52^m$. The mean time derived is, therefore, $22^h 47^m - 16^h 52^m$, or $5^h 55^m$ P.M., while a rigorous reduction (§ 52) gives $5^h 59^m$ P.M.

The difference of 4^m between the two results is due mainly to the approximate value taken for the gain of sidereal time. If the more exact value, $3^m 57^s$, is employed, the two times agree within a minute.

198. Time from meridian transit of stars without instrumental aid. — Instead of estimating the angular distance of a star from the meridian, we may note the time when it is in line with the North Star and the north point of the horizon. Either upper or lower transits may be employed, but it is difficult to obtain satisfactory results if the star is near the zenith.

OBSERVATION. — S. C. O., Monday, Dec. 14, 1896. A small clock was set this evening by "guessing" the interval after sunset, which at the place and season was known to come about four o'clock by standard time. The approximate error of the clock was determined later by noting with the unaided eye the transits of two circumpolar stars. The clock times when β and γ Ursæ Minoris appeared to cross the imaginary meridian below the North Star were $9^h 29^m$ and $9^h 57^m$. The correspond-

ing sidereal times obtained by calculation are $3^{\text{h}} 15^{\text{m}}.4$ and $3^{\text{h}} 43^{\text{m}}.5$ (§ 53).

But when a star is on the meridian, sidereal time is the same as the star's right ascension, or its right ascension plus 12^{h} at lower culmination, so if we assume that the observations are correct, the error of the clock is the difference between the two and we have :

| | β Ursæ Min. | γ Ursæ Min. |
|------------------------|--------------------------------|--------------------------------|
| Clock time of transit, | $3^{\text{h}} 15^{\text{m}}.4$ | $3^{\text{h}} 43^{\text{m}}.5$ |
| Right ascension + 12, | $\underline{2 \ 51 \ .0}$ | $\underline{3 \ 20 \ .8}$ |
| Clock error, | $- 24 \ .4$ | $- 22 \ .7$ |

Thus, the clock was 24 minutes fast at the mean of the two times; but since the comparison of the small clock with the sidereal clock showed the former to be 28.7 minutes fast, the error of the observation was about 5 minutes.

In November, when β Ursæ Majoris was at lower culmination early in the evening, its time of transit was estimated within a minute.

199. Time from an altitude of β Geminorum.—S. C. O., Saturday, Dec. 19, 1896. Four measures of the altitude of β Geminorum, taken with Circles No. 1, gave a mean value $20^{\circ} 43'.5$, which corrected for refraction made the star's zenith distance $69^{\circ} 19'.0$. With this zenith distance the hour-angle of the star, computed as usual (§ 40 (6)), is found to be $- 5^{\text{h}} 47^{\text{m}} 56^{\text{s}}$, whence the error of the watch and of the observation are derived as follows :

| | | |
|-------------------------|--|---|
| Hour-angle | = $+ 5^{\text{h}} 47^{\text{m}} 56^{\text{s}}$ | |
| R.A. β Gem. | = $\underline{7 \ 39 \ 3}$ | |
| Sidereal T., \odot | = $\underline{1 \ 51 \ .7}$ | $\odot = 1^{\text{h}} 51^{\text{m}} \ 7^{\text{s}}$ |
| V_0 | = $\underline{17 \ 54 \ 20}$ | $V'_0 = 6 \ 4 \ 40$ |
| $\odot - V_0$ | = $\underline{7 \ 56 \ 47}$ | Corr. for $\odot = 0 \ 18$ |
| Corr. for $\odot - V_0$ | = $\underline{1 \ 19}$ | Corr. for $\lambda = \underline{48}$ |
| Corr. for λ | = $\underline{48}$ | Mean time = $\underline{7 \ 54 \ 41}$ |
| Mean time | = $\underline{7 \ 54 \ 40}$ | |
| Standard time | = $7 \ 45 \ 13$ P.M. | |

Since the watch time of the observation was $7^{\text{h}} 48^{\text{m}} 21^{\text{s}}$ P.M., the error of the watch was $-3^{\text{m}} 8^{\text{s}}$ (§ 69). But its error independently determined was $-3^{\text{m}} 52^{\text{s}}$, which gives an error of 44^{s} for the observation (§ 176).

200. Time from an altitude and azimuth of β Geminorum. — S. C. O., Thursday, Dec. 17, 1896. The following mean values were obtained as in the preceding section, except that azimuth was included:

| Watch Time. | Altitude. | Azimuth. |
|--|---------------------|-----------------------|
| $7^{\text{h}} 59^{\text{m}} 4^{\text{s}}$ P.M. | $21^{\circ} 3' 0''$ | $250^{\circ} 43' 5''$ |

Having computed the required hour-angle (§ 40 (5)), we find the errors just as above. The steps briefly outlined are:

| | | |
|----------------------|---|--|
| Hour-angle | = $- 5^{\text{h}} 45^{\text{m}} 2^{\text{s}}$ | |
| Right ascension | = $7 39 3$ | |
| | $\oplus = \underline{1 54 1}$ | |
| Stand. T. from Obs. | = $7 55 59$ | $7^{\text{h}} 55^{\text{m}} 59^{\text{s}}$ |
| Watch T. of Obs. | = $7 59 4$ | True Stand. T. = $7 56 15$ |
| Watch error fr. Obs. | = $- 3 5$ | Error of Obs. = $\underline{16}$ |

If the hour-angle in this example is computed from the altitude alone, it is found to be a minute larger.

201. Time from meridian transits of β Orionis and α Virginis. — OBSERVATION 1. — S. C. O., Wednesday, Jan. 22, 1896. By sighting on the North Star, two plumb lines were placed to mark a north and south line (§ 9 b). They were lighted by lamps in the observatory, and the crossing of β Orionis was recorded on the chronograph in sidereal time, though the sidereal clock could not be seen by the observer. Two times were noted: first, when the star appeared to be in line with the plumb lines; and, second, when it was just past them.

The mean of the two is $5^{\text{h}} 11^{\text{m}} 43^{\text{s}}$, and since the star's right ascension is $5^{\text{h}} 9^{\text{m}} 34^{\text{s}}$, the plumb-line transit of the star made the error of the clock $-2^{\text{m}} 9^{\text{s}}$ (§ 69). About half an hour

earlier the error of the sidereal clock determined by the transit instrument was $-2^m 23^s.10$, so the crossing was taken 14^s early.

OBSERVATION 2. — S. C. O., Friday, May 7, 1897. The transit tube was placed and adjusted as usual on the meridian stone on the north (§ 112, Obs. 2). Glass jars filled with water were employed to steady the bobs, as there was some wind when the instrument was first set in the meridian. Only the outer thread was lighted, and thus the inner one appeared dark upon it, with a line of light on either side, as the bright thread looked the larger. There was hardly a breath of wind when α Virginis came into the field of view. Three times were recorded: first, when the star seemed to touch the superimposed threads on the east; second, when it was lost in their light; and, third, when it emerged to view on the other side.

The mean of the observed times was $10^h 1^m 25^s$. The right ascension of Spica, or its sidereal time at transit, is $13^h 19^m 49^s$, and the corresponding standard time $10^h 5^m 32^s$; hence the error of the watch was $+4^m 7^s$; but the true error ascertained independently was $+4^m 15^s$, making the error of the observation 8^s .

202. Right ascension and declination from altitude and azimuth. — We can derive the right ascension and declination of a heavenly body from measures of altitude and azimuth if the time of the observation is known independently. The mathematical calculation required involves little that is new (§ 137).

According to Section 200, the altitude and azimuth of β Geminorum were found to be $21^\circ 3'.0$ and $250^\circ 43'.5$ at $7^h 56^m 15^s$ P.M., corrected watch time. As the date was Dec. 17, 1896, the sidereal time deduced is $1^h 54^m 17^s$. But to find right ascension this time must be combined with the star's hour-angle; we proceed then to compute this angle and the declination as follows (§ 40 (5)):

| | | | | |
|----------------------------|----------------------|-----------------------|----------------------|-----------------------|
| | log tan ζ | = 0.41563 | | |
| $\phi = 42^\circ 19'.0$ | log cos A | = $\frac{9.51865}{n}$ | log tan A | = 0.45630 |
| $M = -40 \quad 40.9$ | log tan M | = $\frac{9.93428}{n}$ | log sin M | = $\frac{9.81416}{n}$ |
| $\phi - M = 82 \quad 59.9$ | log tan $(\phi - M)$ | = 0.91076 | log sec $(\phi - M)$ | = $\frac{0.91401}{n}$ |
| $t = -86 \quad 15.5$ | log cos t | = $\frac{8.81464}{n}$ | log tan t | = $\frac{1.18447}{n}$ |
| $\delta = 27 \quad 59.1$ | log tan δ | = 9.72540 | | |

Since right ascension is equal to sidereal time minus the star's hour-angle at that instant (§ 39), we have then the right ascension of β Geminorum equal to $1^h 54^m 17^s - (-5^h 45^m 2^s)$, or $7^h 39^m 19^s$.

The right ascension given in the Ephemeris is 16^s smaller, and the declination $17'$ larger than the values found here.

203. Sidereal and solar days. — The sidereal day is one revolution of the earth measured by the stars, or, in other words, it is the interval between two successive upper culminations of the same star at the same place. The mean solar day is marked off in like manner by the mean sun, but for most purposes it may be defined simply as the interval between two successive noons shown by a common time-piece, keeping either local or standard time, since the difference in the zeros of these times has no effect upon the length of hours and minutes.

Instead of noon any hour of the day may be chosen. Therefore, to find how sidereal and solar days compare in length, we note carefully two times when a particular star crosses the meridian or other line of reference. It is clear that sidereal and solar days are equal if the times of transit are the same on different nights. On the other hand, sidereal days are the longer if the transits come later; they are shorter if transits come earlier from night to night.

OBSERVATION. — Northfield, Minn., Monday, Feb. 28, 1887. Ladies' Hall, north window. The star chosen was β Ursæ Majoris, and the middle bar of the window sash was taken as

the reference "line." I began watching at 7^h 15^m P.M., and at 7^h 22^m P.M. the star passed behind the window sash. On the following evening β was observed from the same place, and at 7^h 17^m.5 it passed again behind the same bar of the window. Hence, according to these observations, the sidereal day is 4^m.5 shorter than the mean solar day. (S. E. G.)

The effect of errors in observing is diminished if a number of days intervene between the two observations, and it is well, if possible, to choose a star in the south not very far from the equator.

On May 7, 1897, when α Virginis crossed the meridian, the time determined by the transit tube was 10^h 5^m 40^s P.M. (§ 201). June 1, 25 days later, the transit found by the same instrument and the same observer came at 8^h 28^m 7^s P.M. Since, then, 25 sidereal days are 1^h 37^m 33^s shorter than 25 mean solar days, one sidereal day is 3^m 54^s shorter than a mean solar day — a result which agrees with the value given by Chauvenet (Vol. I, Art. 49) within 2^s.

204. Double stars in Taurus. — Astronomers have exclusive rules about admitting double stars into their catalogues, but students who observe without telescopes may be allowed to call any star double when an opera-glass is required to divide it, or when the components are no farther apart than Alcor and Mizar of ζ Ursæ Majoris.

OBSERVATION. — S. C. O., Monday, March 14, 1898. The first star examined was θ Tauri, and though I could divide it with the naked eye, an opera-glass was employed. The line joining the components was nearly perpendicular to the line between α and γ Tauri. In brightness the two stars were nearly equal, slightly exceeding Alcor, but the distance separating them was hardly half that between Alcor and Mizar. The stars σ^1 and σ^2 appeared like the θ 's as regards distance and comparative brightness, but they were fainter and looked bluer. The κ stars

were a little closer than the θ 's and showed marked contrast in brightness. The components of ν were also unequal. They were fainter and about twice as far apart as θ^1 and θ^2 . I was unable to see 80 Tauri with the naked eye, and with the opera-glass it was difficult to separate the two stars, although the space between them was about the same as that between the components of θ . Both δ^1 and δ^2 were easily seen with the naked eye, but they were farther apart than Alcor and Mizar.

The opera-glass used was an old one, nearly worn out, which magnified about 2.5 diameters. (M. M. H.)

205. Change in the brightness of stars. — There are a number of bright stars which wax and wane, so that changes in their light are noticeable to the naked eye. The critical point for astronomers to determine is the exact time when they are brightest or faintest, that is, their times of maxima or minima. But beginners should at first attempt little more than to pick out stars from time to time which match the variable in brightness.

Since it is difficult to find comparison stars sufficiently near which exactly meet this condition, the need of some definite scheme for estimating differences in magnitude soon becomes apparent. The method to be recommended is the one known as Argelander's. Its essential feature consists in providing explicit rules for comparing the light of one star with that of another, by means of grades or "steps." A full description of the method may be found in a pamphlet by E. C. Pickering, entitled "Variable Stars of Long Period."

With the author's permission the following definitions of steps are taken substantially as given there, except that for brevity the sign $>$ is used to signify "brighter than."

When two stars, a and v , are compared, if we have $a > v$ as often as $v > a$, the two are assumed to be equal.

The difference in the brightness of a and v is called one step when they are so nearly equal that it is difficult to decide

at once which is the brighter, but where in a given number of estimates, we find $a > v$ more times than $v > a$.

The difference is said to be two steps when in most cases the estimate is $a > v$, though sometimes the comparison stands $v > a$.

The difference is three steps when one star is without doubt brighter than the other, that is, when the estimate is invariably $a > v$, and yet the difference always remains small, hardly larger than necessary to prevent writing $v > a$.

It may seem strange that in defining steps no reference whatever is made to stars appearing equally bright. A little observation, however, will show the truth of Pickering's statement: "If two stars of equal brightness are watched for a few seconds, the relative brightness will appear to vary."

Beginners are likely to have a large and variable "step," and also to overlook the importance of choosing comparison stars with great care. It will, therefore, not be amiss to summarize briefly some of the principal suggestions given by astronomers who are authorities on the subject.

The eye should be trained to recognize small differences in the light of stars, and grade like differences by the same step. As an aid in gaining uniform values for steps, stars whose brightness has been in most cases carefully determined should be observed in order of magnitude, so that each succeeding star shows a change of not more than three steps.

Comparison stars should have about the same altitude as the variable, and lie near it in the sky. Two or three should be chosen, one of them being if possible brighter, and another fainter than the variable. A star which appears double to the naked eye, or is itself a variable, ought not to be employed, nor should we take one lying near a bright star.

The variable and its comparison star must be examined separately, and no effort made to look at both at the same instant.

In any careful study of variable stars it is essential to have

the Harvard Photometry. Chandler's "Catalogue of Variable Stars" should be accessible for reference, and many will also find it helpful to have at hand Pickering's pamphlets on the subject, and the articles by J. A. Parkhurst, in Vol. I of *Popular Astronomy*.

The method of observing variable stars described above gives very accurate results when employed by those who have skill and experience. Students at first are apt to feel that there is something vague and unsatisfactory about the work, but with patience and perseverance this impression soon gives place to well-assured confidence in making comparisons on a definite scale.

In order to know on what nights to watch particular stars, it is better to refer to some current astronomical publication which gives the times of maxima or minima only approximately, instead of consulting authorities where the times are predicted as accurately as possible (§ 2).

206. Varying magnitudes of Algol. — During the short space of nine hours, the light of Algol varies in such a striking manner that no one who watches at the right time, that is, near a minimum, can fail to note a change in brightness (Young, Art. 848, E. Art. 453). Since the star is usually of the second magnitude, it is easily identified, and as a preliminary step it ought to be compared with stars near it on several nights before any effort is made to observe a minimum.

OBSERVATION 1. — Fifth story, 27 West 11th Street, New York City, Friday, Nov. 29, 1895. The October number of *Popular Astronomy* contains a prediction of a minimum of Algol for to-night. The city is not a favorable place for observation, but from the fire escape I obtained a good view of the sky about β Persei. Since the moon was in the neighboring constellation Aries, and lacked but three days of being full, it was necessary to choose comparison stars very near the variable.

When first observed, at 7^h 30^m P.M., Algol seemed only as bright as γ Persei, though on the preceding night it looked nearly as bright as α Persei.

Later in the evening, from nine to ten o'clock, I watched the star quite steadily, and about half after nine it appeared no brighter than ρ Persei. For some minutes no change could be detected, and then clouds came up and prevented further comparisons. (L. S.)

In such observations as these it is not wise to watch a star steadily. The eye can judge better with regard to changes if comparisons are separated by intervals of half an hour or more. The choice of ρ Persei was also unfortunate, as that star is itself a variable. In spite, however, of these drawbacks, the observation clearly indicates a minimum at about half after nine; for, according to Chandler's "Catalogue of Variable Stars," the lowest magnitude of Algol is 3.5, and the highest of ρ Persei is 3.4.

From the Greenwich time of minimum given in the *Companion to the Observatory* for 1895, we ascertain that the minimum of Algol came in eastern standard time at 9^h 9^m P.M., November 29.

OBSERVATION 2. — Ashfield, Mass., Saturday, Oct. 23, 1897. Between six and ten o'clock this evening I was going from Northampton to Ashfield on the cars; but knowing that a minimum of Algol was predicted to occur during these hours, I watched the star from time to time at the different stations.

The first comparison was taken at the Northampton station, 6^h 15^m P.M. The variable was then scarcely brighter than the little star 30 Persei. It was about equal to η Persei, 7^h 5^m, when observed at the station of Shelburne Falls. At Charlemont, 7^h 34^m, it was nearly as bright as δ Persei. An hour later it was fully as bright as this star.

When I reached Ashfield, 9^h 30^m P.M., Algol was as bright as β Arietis. It appeared a trifle brighter at 10^h 15^m, though not as bright as α Persei or α Arietis. (L. B.)

On the same evening another observer at Northampton compared Algol with the neighboring stars by means of steps (§ 205). The record thus obtained is as follows:

| Time. | Comparisons. | | |
|--------------------------------|----------------------|-------------------------|-----------------------|
| 6 ^h 57 ^m | $v = \eta$ Persei | γ Persei 2 > v | $v 1 > \tau$ Persei |
| 8 35 | $v 1 > \eta$ Persei | γ Persei 1 > v | $v = \delta$ Persei |
| 9 35 | $v 2 > \eta$ Persei | γ Persei = v | $v 1 > \delta$ Persei |
| 10 0 | $v 1 > \zeta$ Persei | γ Andr. 1 > v | $v 1 > \gamma$ Persei |

In these observations the variable is, as usual, designated by v , and the symbols = and > signify "equal in brightness," and "brighter than." (H. W. B.)

As the brighter object should always stand first in making a comparison, the signs = and > may be omitted after a little practice.

On October 23 the true time of minimum, unknown to the observers, was 6^h 21^m P.M., and if the regular interval is allowed, Algol should have regained its usual brightness at ten o'clock.

207. Approximate maximum of α Ceti.—There are at most only two brief periods in a year when Mira, in the constellation Cetus, ranks as a bright star easily visible to the naked eye. It is an irregular variable with a different light curve in different years; and as yet it has not been possible to predict the exact times and magnitudes of its maxima (Young, Art. 846, E. Art. 451).

In connection with the study of variable stars in general astronomy, α Ceti was observed at Smith College in the winter of 1896–97. Between December 1 and February 24 eight observers made 45 comparisons, each including two or more separate estimates of relative brightness depending upon different stars. Before any reductions were made three comparisons were rejected as haze, and city lights were mentioned in the accompanying notes.

The mean value of each observer's step was determined

according to the method described by J. A. Parkhurst in *Popular Astronomy*, January, 1894. The magnitudes of the comparison stars employed were obtained from Harvard College Observatory, through the courtesy of Professor Pickering. It was then only necessary to reduce the steps to magnitudes in order to plot the following curve.

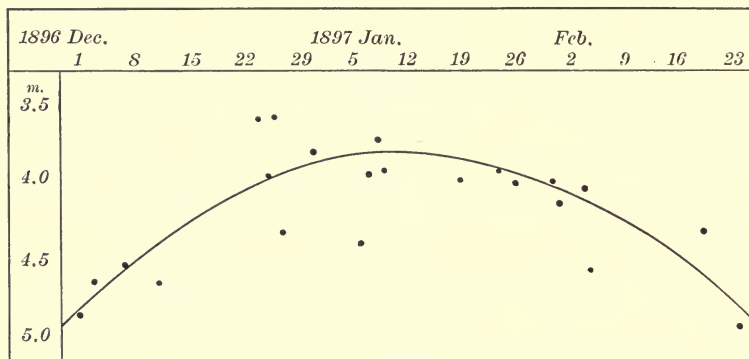

FIG. 33. — Maximum of *o* Ceti.

In this figure the intervals in days are represented by abscissas and the varying magnitudes by ordinates. As the heavy dots indicate a mean value obtained by two or more observers, they were given more weight in drawing the curve than the lighter ones which mark the magnitudes found by a single observer.

Although the comparisons were all made by those who had had little experience, we may conclude with a good degree of confidence that *o* Ceti was of about the fifth magnitude the first of December and the last of February; and that it reached a maximum, a little over a fourth, during the first week in January.

During this appearance of Mira, Mr. Henry M. Parkhurst fixed two maxima, one on December 19, and the other on January 2 (*Astronomical Journal*, No. 400). One maximum is given by Dr. A. A. Nyland, on January 11, when he made the magni-

tude 3.70 or 3.5 on the scale of Schönfeld and Argelander (*Astronomische Nachrichten*, No. 3426).

Of course no reference was made to the results obtained by others, until our own were reduced and the curve drawn as in Fig. 33 (§ 2).

208. Motion of the Milky Way. — From casual observation we learn that the arch of the Milky Way is differently placed with regard to our horizon on different nights and at different hours on the same night. Its position at any time is determined when the azimuth of the points of intersection are known, and the altitude and azimuth of the highest point of the arch. These angles instead of being measured may be estimated directly by the eye, but the accuracy of results will depend largely upon the nature of the horizon and the effect of artificial lights.

In undertaking to make estimates at Smith College Observatory, the northeast horizon was given up as hopelessly bad. Trees and large buildings were near at hand (§ 107), and electric lights especially bright in that direction. Toward the southwest the view was comparatively unobstructed, and intersections were located there at the beginning and end of a two-hour period.

To obtain a fixed point of reference the meridian line (§ 9) was prolonged to the horizon on the south, and a chimney happening to be in that direction marked the south point against the sky. While it was clear that the Milky Way met the horizon not far from this point, it was difficult to locate the centre of the intersection, as the whole band of light could not be followed to the horizon. Where the arch was distinctly visible higher up, its centre was located and the vertical circle of that point met the horizon near ι Scorpii. Taking this star to fix the intersection, I estimated that its azimuth was equal to the distance between ϵ Sagittarii and κ Scorpii, two stars near the horizon and not far from the distance to be measured (§ 6).

When this observation was made, the Milky Way approached nearest the zenith a little east of the meridian. Having taken care to shield the eyes from bright lights during some minutes before, I picked out 29 Vulpis as the star which fixed the lower boundary of the highest point of the arch. The altitude of this star was a little more than two thirds the distance between the horizon and zenith, that is, over 60° , so it was called 65° (§ 104, Obs. 1). In estimating the angle between the east point of the horizon and the vertical circle of 29 Vulpis, twice I called it a

TABLE XV.— POSITIONS OF THE MILKY WAY, JULY AND AUGUST, 1896, NORTHAMPTON, MASS.

| TIME. | S.W. INTERSECTION. | | N.E. INTERSECTION. | | HIGHEST POINT OF ARCH. | |
|--|--------------------|--------|--------------------|--------|------------------------|---------------|
| | OBS. | GLOBE. | OBS. | GLOBE. | OBS. ALTITUDE. | OBS. AZIMUTH. |
| July 17 11 ^h 24 ^m | 16° | 19° | 215° | 211° | 64° | 318° |
| 13 26 | 43 | 43 | 230 | 232 | Arch passed | |
| Aug. 17 11 ^h 37 ^m | 44 | 45 | 231 | 234 | through zenith. | |

quarter of the 90° between the east and south points, and once a third of that angle, which gave a mean value of 27° corresponding to an azimuth of 297° .

On the same night, two hours later, a second observation was made of the position of the Milky Way. At that time the arch passed through the zenith, though not centrally. The south-west intersection had moved west, so that its azimuth, estimated as part of the 90° between the south and west, was taken as 37° .

Immediately after each of these observations, measures were made with the Circles, altitude and azimuth being reckoned from the same points employed by the unaided eye. Since the motion of the Milky Way was so rapid, the two sets of values are not strictly comparable; but the Circle readings (Table XV)

may be employed to give an approximate test of direct eye estimates. According to the latter, the hourly motion of the southwest intersection was 10° , while the Circles gave 14° . The estimated and observed altitudes of the highest point of the arch a little after eleven o'clock differ only a degree, but its estimated azimuth, in the colloquial phrase of astronomers, was "wild." Probably the east point of the horizon was incorrectly taken, but it is hardly possible to make an accurate naked-eye estimate of the azimuth of any object having an altitude of more than 60° .

In the table on the opposite page are given the two positions of the Milky Way fixed by the Circles, July 17, and a third one determined in like manner a month later.

The angles in the table, obtained from the celestial globe, were read by taking the same points employed as central in the different observations.

By comparing the three positions we see that, just as in the case of the ecliptic, the motion of the Milky Way appears to be about the same whether observations are made two hours apart on the same evening, or at the same hour of the evening, but separated by a month.

CHAPTER IX.

OBSERVATIONS FOR AN INCH-AND-A-HALF TELESCOPE.

THE observations suggested in this chapter are selected especially with reference to students who are using a home-made instrument.

After suitable lenses have been obtained it is not a difficult matter to put together a small telescope (§§ 19, 20), and the operation gives, as nothing else can, a vivid idea of the essential parts and their connection with one another. It is also a valuable feature of astronomical training to keep a home-made telescope in good adjustment, so that the images are without wings and sharply defined.

QUESTIONS.

209. The sun.

1. Does the sun look larger when seen with the telescope or with the naked eye?
2. What proportional part of the field of view does it occupy?
3. What is the diameter of the field of view in minutes and seconds determined by a central transit of the sun? Of a star?
4. Which is the brighter, the limb or the centre of the sun's disk?
5. Does the sun appear flat or spherical?
6. How many spots are visible on the sun at any one time?
7. On what part of the disk are they situated?
8. What is their form and color? How do they compare with one another in form and size?
9. Are the spots entirely distinct or do they form groups?
10. Is it possible to distinguish in any spot the umbra and the penumbra?
11. If a spot or group can be identified from day to day, do you find it moving toward the east or west limb?

12. How many days does it take a spot to pass from one limb to the other ?

13. From these observations how long do you conclude that it takes the sun to turn on its axis ?

210. The moon.

1. How does the telescope affect the color and brightness of the moon ?

2. How do lunar shadows compare in darkness with shadows on the earth ?

3. Do the shadows extend toward the terminator or in the opposite direction ?

4. Do changes in the moon's phase affect its appearance as flat or spherical ?

5. What is the difference in the terminator as seen with an opera-glass and with the telescope ?

6. Near full moon what peculiarity is noticeable about Tycho ?

7. Are the tops of lunar mountains ever visible when detached from the rest of the illuminated portion ?

8. What mountains are especially noted as "shining mountains" ?

9. How can it be shown whether Apollonius was right or wrong in holding that lunar markings are the reflections of configurations on the earth ?

10. Under what conditions have you seen a star occulted by the moon ? At what time did it disappear ?

11. How many of the following lunar objects are you able to identify ?

(1) Mare Crisium.

(2) Mare Fœcunditatis.

(3) Mare Nectaris.

(4) Mare Tranquillitatis.

(5) Mare Serenitatis.

(6) Palus Somnii.

(7) Lacus Somniorum.

(8) Mare Vaporum.

(9) Mare Imbrium.

(10) Sinus Iridum.

(11) Oceanus Procellarum.

(12) Mare Nubium.

(13) Mare Humorum.

(14) Mare Frigoris.

(15) Sinus Medii.

(16) Cleomedes.

| | |
|--------------------|---------------------|
| (17) Tralles. | (34) Plato. |
| (18) Proclus. | (35) Mt. Pico. |
| (19) Catharina. | (36) Clavius. |
| (20) Cyrillus. | (37) Tycho. |
| (21) Theophilus. | (38) Copernicus. |
| (22) Julius Cæsar. | (39) Eratosthenes. |
| (23) Boscovich. | (40) Gassendi. |
| (24) Aristoteles. | (41) Kepler. |
| (25) Parrot. | (42) Aristarchus. |
| (26) Albategnius. | (43) Herodotus. |
| (27) Hipparchus. | (44) Schickard. |
| (28) Manilius. | (45) Grimaldi. |
| (29) Aristillus. | (46) The Alps. |
| (30) Arzachel. | (47) The Apennines. |
| (31) Alphonsus. | (48) Caucasus Mt. |
| (32) Ptolemæus. | (49) Langrenus. |
| (33) Archimedes. | (50) Petavius. |

211. Planets and comets.

1. Is the disk of Mercury visible in the inch-and-a-half glass employed ?
2. Can phases of this planet be detected ?
3. What phase of the moon does an observed crescent of Venus resemble ?
4. How do Mercury and Mars compare in size and color ?
5. How do the telescopic appearances of Mercury, Venus, and Mars differ from those obtained directly with the unaided eye ?
6. As seen in the telescope, does Jupiter look larger than with the naked eye ? Does it look brighter ?
7. Does the telescope have any effect upon its color ?
8. Are the belts visible ? Where are they located ?
9. Are they seen more distinctly near the centre or near the limb of the planet's disk ?
10. How does the direction of Jupiter's motion across the field compare with that of stars ?
11. How many of Jupiter's moons are visible ?
12. How are they placed with regard to the east and west limbs

of the planet? With regard to the equator prolonged on either side?

13. What is the distance of each satellite from the planet's centre, if the distance of the nearest is taken as unity?

14. During one evening is it possible to detect any motion in any satellite?

15. How do you rank the satellites with regard to brightness? Are disks visible?

16. Which looks the larger in the telescope, Jupiter or Saturn?

17. What appearance do the rings of Saturn present?

18. How are Uranus and Neptune identified?

19. In how short a time can a comet's motion be detected with the telescope?

20. Is it possible to note changes in a comet's physical appearance in an interval of a few hours?

21. What answers to questions in Section 157 are obtained by using a telescope?

212. Stars.

1. Does a telescope make a star look larger or brighter?

2. How is the twinkling of a star affected by a telescope?

3. Does a bright star have a disk when the telescope is carefully focused?

4. Where are stars found which move quickly across the field of view? Where are those found which move very slowly?

5. When the telescope is turned toward the north, what stars are found crossing the field in opposite directions?

6. How does a telescopic view of the Pleiades differ from that obtained with an opera-glass? Is the small triangle of stars near Alcyone visible?

7. How many of the following double stars are you able to identify?

(1) γ Andromedæ.

(6) κ Boötis.

(2) ζ Andromedæ.

(7) μ Boötis.

(3) ψ^1 Aquarii.

(8) ι Cancræ.

(4) ζ Aquilæ.

(9) δ Canis Min.

(5) ζ Aurigæ.

(10) σ^2 Capricorni.

| | |
|-------------------------|--------------------------|
| (11) 37 Ceti. | (26) ϵ Lyræ. |
| (12) 24 Comæ Berenices. | (27) ζ Lyræ. |
| (13) δ Corvi. | (28) η Lyræ. |
| (14) β Cygni. | (29) 61 Ophiuchi. |
| (15) α^2 Cygni. | (30) 39 Ophiuchi. |
| (16) 61 Cygni. | (31) δ Orionis. |
| (17) γ Delphini. | (32) σ Orionis. |
| (18) ν Draconis. | (33) ϵ Pegasi. |
| (19) ζ Geminorum. | (34) ϵ Sagittæ. |
| (20) δ Herculis. | (35) β Scorpii. |
| (21) κ Herculis. | (36) ν Scorpii. |
| (22) τ Leonis. | (37) θ Serpentis. |
| (23) 93 Leonis. | (38) τ Tauri. |
| (24) γ Leporis. | (39) ϕ Tauri. |
| (25) β Lyræ. | (40) ζ Ursæ Maj. |

8. If additional stars are taken from the list given in the Almanac of the Society of Wales, what ones are divided?

9. How do the components of any star examined compare in brightness? In color?

10. How does the distance between any two stars examined compare with that between the ϵ 's in Lyræ? With that separating the components of some other reference star?

11. On what date nearest a minimum is α Ceti* visible in the telescope employed?

213. Milky Way and nebulæ.

1. If a bright section of the Milky Way is examined, how many stars are counted in the field of view?

2. How do the stars differ in brightness?

3. What proof is found that a part of the Milky Way has actually been resolved?

4. Is any unresolved nebulous matter still visible?

5. If the objects given in Section 187 are examined, how does

* If the Bonn charts are not at hand, the star may be identified from copies of the required section, which are given in *Popular Astronomy*, December, 1895, and April, 1898.

the telescopic appearance differ from that obtained with the naked eye or opera-glass?

6. How many stars are counted in the clusters that are resolved?

7. If twenty clusters and nebulae, not found in Section 187, are chosen from Webb's "Celestial Objects," how does the actual appearance in the telescope correspond with the description in the book?

SUGGESTIONS AND ILLUSTRATIONS.

214. Angular diameter of the sun. — S. C. O., Friday, Apr. 8, 1898. Home-made telescope No. 1 (§ 20) was placed on the broad stone step at the south door of the observatory. The sun was brought into the field of view, and the cross-threads moved till they marked approximately the horizontal and vertical diameters of the field. To determine what proportional part of the field was occupied by the sun's disk, five estimates were made, corresponding to five different positions of the sun, and a mean value of 0.72 obtained. (B. F. F.)

Since the diameter of the field of view, unknown to the observer, is 47' (§ 20 d), the angular diameter of the sun is 34', according to this observation. The Ephemeris gives 32' for the particular date.

215. Sun's rotation from sun spots. — In the summer and fall of 1894 there were many large groups of spots, although the time of maximum came in the preceding year. These groups were frequently observed with telescope No. 1, and sketches obtained for determining the approximate period of the sun's rotation.

Fig. 34 shows the position of spots on the morning of July 11, where the dotted line marks the sun's equator, and the arrow gives the direction in which the spots were moving. Thus, group *a* was just coming into view on the eastern limb, that designated *b* had advanced well toward the centre, and group *c* was approaching the western limb.

An examination of six sketches made in August, before the

12th, showed that on the afternoon of August 7 (Fig. 35) the groups *a*, *b*, and *c* again occupied practically the same position as on July 11. In both figures the irregular lines near the limb of the sun enclose conspicuously bright faculæ.

The difference in time between the two observations, $27^{\text{d}} 9^{\text{h}} 45^{\text{m}}$, or $27^{\text{d}}.41$, is the approximate time taken for the sun to turn

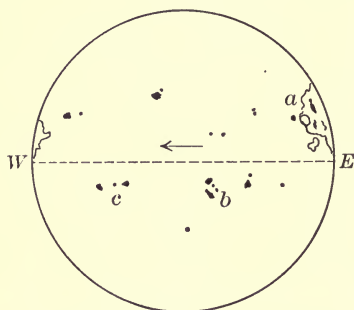

FIG. 34. — July 11, 7^h 35^m A.M.

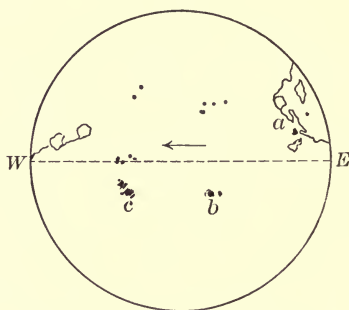

FIG. 35. — Aug. 7, 5^h 20^m P.M.

SUN'S ROTATION SHOWN BY SUN SPOTS.

on its axis. In like manner three other pairs of sketches were selected in which the same groups of spots were found in the same relative position with regard to the equator and limbs of the sun. The mean of the four times thus determined gives 27.22 days as the sun's period of rotation. (A. E. T.)

The interval found directly by observation is of course the apparent and not the real period of rotation; for while the sun is turning on its axis the earth is moving eastward in its orbit, and consequently the sun, having made one complete rotation, must still turn a little farther in order to make the spots appear to us in the same relative position as at first.

To deduce the true from the observed period, we employ the observed value $27^{\text{d}}.22$ in the usual formula (Young, Art. 281, E. Art. 180), and obtain

$$\frac{1}{T} = \frac{1}{27.22} + \frac{1}{365.25}, \text{ or } T = 25^{\text{d}}.33.$$

216. Lunar objects identified.— With the help of a small telescope it is possible to identify a large number of lunar objects. Nearly 50, including seas, are given in Fig. 36. This partial map of the moon was made Dec. 2, 1897, 84 Elm Street, North-

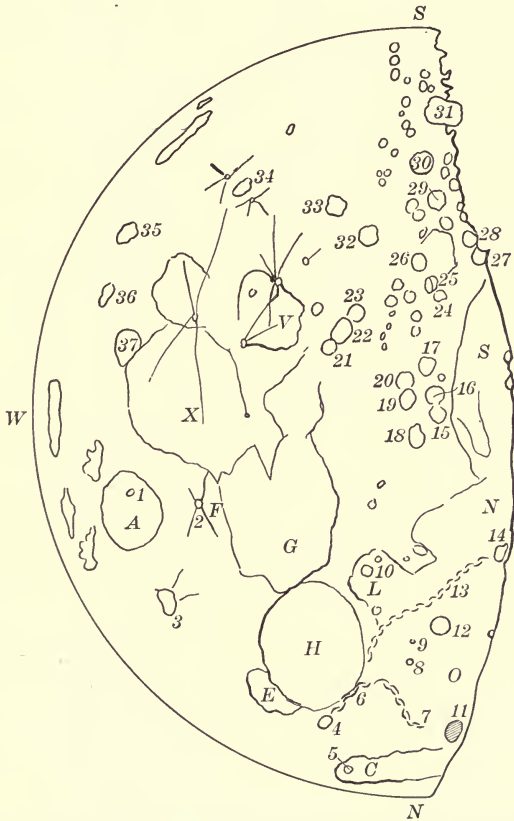

FIG. 36. — Age 8.56 days. The Moon in an Inch-and-a-half Telescope.

ampton, Mass. The evening was clear and cold, and the seeing good. The time occupied was from 5^h 10^m P.M. to 6^h 15^m P.M., and the age of the moon given corresponds to the mean of the two. Doubtless the observation would have taken longer if I

had not before had practice in sketching the moon at different phases.

In making the drawing I employed home-made telescope No. 1, and having placed one of the cross-threads (§ 20 d) to mark approximately the central meridian, I located objects as accurately as possible by the eye, beginning with the west limb and passing to the terminator. At the time no maps of any kind were consulted, but some days later, when the following key was made, a few corrections were introduced. (A. E. T.)

KEY TO LUNAR MAP (Fig. 36).

- | | |
|--------------------------|---------------------|
| A. Mare Crisium. | V. Mare Nectaris. |
| H. Mare Serenitatis. | O. Mare Imbrium. |
| G. Mare Tranquillitatis. | N. Sinus Æstuum. |
| L. Mare Vaporum. | S. Mare Nubium. |
| F. Palus Somnii. | C. Mare Frigoris. |
| X. Mare Fœcunditatis. | E. Lacus Somniorum. |
| 1. Picard. | 20. Parrot. |
| 2. Proclus. | 21. Theophilus. |
| 3. Cleomedes. | 22. Cyrillus. |
| 4. Eudoxus. | 23. Catharina. |
| 5. Aristotle. | 24. Purbach. |
| 6. Caucasus Mt. | 25. Regiomontanus. |
| 7. Alps. | 26. Walter. |
| 8. Aristillus. | 27. Pitatus. |
| 9. Autolycus. | 28. Gauricus. |
| 10. Manilius. | 29. Tycho. |
| 11. Plato. | 30. Maginus. |
| 12. Archimedes. | 31. Clavius. |
| 13. Apennines. | 32. Stöfler. |
| 14. Eratosthenes. | 33. Maurolycus. |
| 15. Ptolemæus. | 34. Piccolomini. |
| 16. Alphonsus. | 35. Petavius. |
| 17. Arzachel. | 36. Vendelinus. |
| 18. Hipparchus. | 37. Langrenus. |
| 19. Albategnius. | |

217. Sunrise on the Teneriffe Mountains. — Twice during each lunation the terminator comes to every object on the moon, once when the moon is waxing, and again when it is waning. Thus, all objects may be examined under sunrise or sunset illumination. The daily advance of the terminator is at the rate of $12^{\circ}.19$ (Young, Art. 235); so in order to find when it reaches any particular formation, we ascertain how long a time is required for it to pass from either limb to the given object.

For example, we see from Alger's map of the moon that the Teneriffe Mountains are in longitude 15° from the central meridian, reckoned eastward (*Companion to the Observatory*); and hence their distance from the west limb is $90^{\circ} + 15^{\circ}$, or 105° . Since, then,

$$\frac{105}{12.19} = 8.6,$$

the sun should rise on these mountains 8.6 days after the instant of new moon, that is, when the moon is 8.6 days old. This age was reached in May, 1898, on the 28th, about 10^h P.M., Northampton, Mass., as the moon was new 8^h A.M., May 20 (§ 46).

Owing to libration, there may be a discrepancy between the calculated and observed position of the terminator near the limb; but it is not necessary to be very precise in the preliminary computation, for the lunar day is so long that two or three hours of our day have little effect there.

The following extract is taken from notes made when the moon was examined, on the 28th, with home-made telescope No. 2 (§ 223).

“S. C. O. About eight o'clock the Teneriffe Mountains were seen on the terminator. They showed very plainly as little bright dots with dark shadows extending in the direction of the eastern limb.”

(E. C. F.)

218. Partial eclipse of the moon. — S. C. O., Friday, Jan. 7, 1898. A little before the eclipse began, at 6^h 40^m P.M., I exam-

ined the moon with telescope No. 1, and found the upper part enveloped in a smoke-like cloud extending as far as Tycho.

The first contact of the real shadow came at 6^h 46^m, and 8 minutes later its advancing edge had traversed half the distance from the limb to Tycho, reaching the outer ring of the crater at 7^h 18^m. As seen in the telescope, the shadow passed downward, and at 7^h 35^m it was moving away from Tycho, so I called that the time of maximum phase of the eclipse. The shadow left the moon midway between Tycho and Mare Fœcunditatis about 8^h 20^m P.M.

Throughout the eclipse the shadow was much darker, and its boundary line more clearly defined when seen directly with the naked eye than with the telescope. An opera-glass, however, gave the sharpest outline. The effect of the eclipse on the sky and on terrestrial objects was slight, something like that seen when a thin cloud passes over the full moon. In the telescope both the eclipsed and uneclipsed portions were light silvery gray in color, without a tinge of red or yellow, and yet no objects were visible within the shadow.

Both with the naked eye and the telescope I estimated that the eclipse extended over the moon one sixth of its diameter.

(A. E. T.)

219. Face appearance of the bright planets.—S. C. O., Wednesday, Apr. 21, 1897. All of the bright planets were observed this evening with telescope No. 1.

Venus was first brought into the field of view about 7^h 20^m P.M., and though its altitude was little over 6°, it showed at once a sharply defined crescent, the horns pointing downward. In shape and size it looked like the moon when three days old, but its uniform brightness, unbroken by effects of light and shade, was in marked contrast to our satellite. Compared with an observation made about a week earlier, I thought I could distinguish that the crescent had grown narrower. No trace of the unilluminated part of the planet was visible.

Mercury was next examined, when about 8° above the horizon. It was found to resemble very closely a bright red star, though at first it gave the impression of a small disk, not exactly circular.

Mars at an altitude of 40° was redder than Mercury, but otherwise it differed little in appearance from that planet.

When the telescope was directed to Jupiter at $9^h 30^m$ P.M., a clearly defined circular disk was at once apparent. The four satellites were visible, but there was no trace of the belts which are sometimes seen with the telescope employed.

Saturn, the remaining bright planet, was examined when it had reached an altitude of 8° or 10° above the eastern horizon. Its distinct yellow color was marked in the telescope, and its oval form could not escape instant recognition. It seemed as if I could distinguish the division between the ball and rings, but perhaps the familiar aspect of the planet in larger telescopes had, unconsciously, undue influence.

220. Configuration of Jupiter's satellites. — S. C. O., Apr. 8, 1898. The four bright satellites of Jupiter, as seen in telescope No. 1 at $8^h 30^m$ P.M., are shown in Fig. 37. At this time the

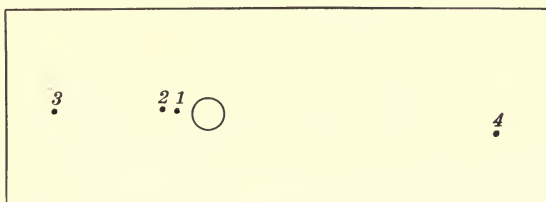

FIG. 37. — Jupiter's Satellites in a Home-made Telescope.

first and second satellites, 1 and 2, were less than the planet's diameter from the west limb. I estimated the distances, respectively, as 0.3 and 0.8 of the diameter, but the third satellite, 3, was called four diameters away; and the distance of the fourth from the east limb was taken as twice that between the third and Jupiter's west limb.

Although the satellites followed approximately the line of direction given by prolonging the equator on either side of the planet, there were distinct variations, as shown in the figure.

When Jupiter was observed under the same conditions half an hour later, no trace was found of the first satellite, and the second was nearer the planet, but no perceptible change was noted in the positions of the other two.

After the observation was finished the numbers which serve as names for the satellites were obtained from the Ephemeris. In spite of the fact that the configuration given there corresponded to a time three hours later than the observation, the satellites were readily identified. The third and fourth were so far removed on opposite sides of Jupiter that there could be no mistake about them; and since the other two were occulted during the given evening, their order in distance from the limb was fixed by the times of disappearance. (B. F. F.)

221. Vesta at opposition. — According to the Berliner Jahrbuch, Vesta, the brightest of the minor planets, was in opposition May 8, 1898. That night was cloudy, but within the following week the planet was observed twice.

OBSERVATION 1. — S. C. O., Monday, May 9, 1898. By taking account of precession (§ 57), Vesta's relative position on the Bonn charts was found for the date of opposition. Telescope No. 1 was then directed toward the required place with the help of β and δ Libræ; and a quadrilateral of stars brought into the field of view which agreed closely with a like configuration on the chart near the place marked for the planet. There was also in the field a fifth object, about the sixth magnitude in brightness; and as no corresponding star could be found on the chart, it was given the symbol for Vesta, \oplus . The other objects were lettered *a*, *b*, *c*, and *d*, and the following estimates made:

$a \textcircled{4} =$ nearly the entire field of view

$d \textcircled{4} = \frac{1}{3}$ field of view

$ab = \frac{1}{3}$ field of view

$ad = \frac{2}{3}$ field of view

$ab = \frac{2}{3} a \textcircled{4}$

$\angle bd \textcircled{4} = 90^\circ$

$\angle ab \textcircled{4} = 90^\circ + 30^\circ$ (F. A. W.)

OBSERVATION 2. — S. C. O., Friday, May 13, 1898. The four stars seen last Monday were examined again, but the fifth object was missing. There could be no doubt about the identity of the quadrilateral, as the new measures for angle and distance agreed almost exactly with those taken at first. Since Vesta was retrograding (§ 171),

I swept to the west, looking for a bright object compared with those in the vicinity; for in that direction there was no sixth magnitude star nearer than 2° . At about the same altitude as the quadrilateral, but farther west by nearly twice the field

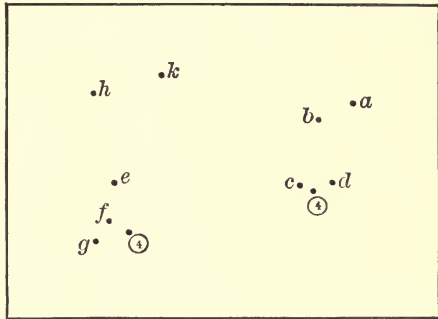

FIG. 38. — Two Positions of Vesta.

of view, I found such an object. Three stars in the same field and two brighter ones just outside at the upper part were identified on the chart, but no star was found to correspond with the brightest object first mentioned. That without doubt was Vesta. To fix its position, estimates were made as follows:

$e \textcircled{4} = \frac{1}{2}$ field of view

$g \textcircled{4} = \frac{1}{4}$ field of view

$\angle e \textcircled{4} g = 90^\circ$

$h \textcircled{4} = 1\frac{1}{3}$ field of view, approx.

$hk = \frac{2}{3}$ field of view

$\angle kh \textcircled{4} = 90^\circ$

On the evening of May 9 Vesta was visible to the naked eye, and at any time during the observations it was easily seen in a small opera-glass; but its motion could be detected more readily in the telescope.

Fig. 38 shows the two positions of the planet plotted from the data obtained from the observations given above. (F. A. W.)

222. Comet *b*, 1898 (Perrine). — OBSERVATION 1. S. C. O., Saturday, March 26, 1898. Knowing only the place of the comet given in the newspapers on the date of discovery, March 20, I looked for it first with a portable telescope, $4\frac{1}{2}$ inches in aperture. After sweeping a short time, the comet was picked up a little after 3^h A.M. During the following hour it was watched from time to time till motion was detected with certainty.

At 4^h 13^m A.M. the comet was found with the small telescope No. 1; and by means of stars in the field of view at the same time its place was fixed very near the sixth magnitude star 12, below κ Pegasi (§ 221). (A. E. T.)

OBSERVATION 2. — S. C. O., Saturday, Apr. 2, 1898. The working ephemeris given in the *Science Observer*, Special Circular No. 117, aided in finding the comet this morning. With telescope No. 1 its place was seen to be nearly in line with π and ι Pegasi, and about a third of the distance between these stars below π . Hence it is clear from the globe that its average motion during the week was over a degree a day.

In general character the comet resembled a miniature naked-eye comet. It was certainly not the hazy patch of nebulosity which often appears as a telescopic comet. The nucleus, brighter than any other object in the field, was like a star seen through a thick haze. The tail was approximately V-shaped and extended away from the sun. It was traced only a tenth of a degree, but the time of observation was about four o'clock, and the sky was growing bright.

223. Wide doubles in Cygnus. — S. C. O., Tuesday, May 31, 1898. The first star observed was the noted triple, \circ Cygni. Its components were so far apart that distances could be estimated in terms of the field of view. In this way I made the space between the two brighter stars 8'. Later I found that Webb gives it nearly a third smaller. The stars of 48 were

also found widely separated. They were equal in brightness, but not nearly as bright as the α stars.

Compared with α and 48 Cygni, β and 61 are close doubles. The space dividing the components of 61 I called 0.7 of that between the components of β . The former stars differed little in color and brightness, but one of the β stars was brighter than the other and decidedly yellow. In like manner it was noticed that the brightest star in the triple was yellow.

Owing to an oversight in my record this evening, I am not certain whether telescope No. 1 or No. 2 was employed, but the two instruments have practically the same aperture and the same magnifying power. (E. I. B.)

224. The star cluster Præsepe.—S. C. O., Friday, May 13, 1898. Between nine and ten this evening, telescope No. 2 was employed in examining the star cluster in Cancer. The width of the cluster in the direction of the star-line $\gamma\delta$ Cancri was equal to about twice the field of view. In the opposite direction, that is, at right angles to $\gamma\delta$, it extended farther. Near the centre the stars were condensed, but more scattered toward the edges. The marked configurations were a quadrilateral and a sickle like that in Leo, though the two were not distinct, as the stars corresponding to γ and η Leonis were required in forming the quadrilateral. The four stars in this figure were, with one exception, the brightest in the cluster.

Below the quadrilateral there was an interesting triple star; and, having turned the telescope upon ϵ Lyræ, I decided that the distance between the components of the triple was only a third or a fourth of that separating ϵ^1 and ϵ^2 . There were seen also three pairs of double stars with distances about equal to those found in the triple star.

It was difficult to make an accurate count of the stars in the cluster, as at least two motions in different directions were necessary to bring all of the stars into the field. I made the number

38, which indicates that this home-made telescope is comparable with Galileo's first telescope, as he records having seen 36 stars in Præsepe with his instrument. (L. H. W.)

225. The Milky Way near β Cygni. — With telescope No. 1 several settings were made on the Milky Way near β Cygni. In each case the general appearance was the same, that of a loose cluster of stars entangled in nebulous matter. The brightest stars were about the seventh magnitude, and the fainter ones, I think, below the eighth. The number counted in the field at one time varied from eight to twelve.

(H. W. B.)

APPENDIXES.

APPENDIX A.

A HOME-MADE TELESCOPE.*

BY DR. GEORGE PYBURN.

THE lenses requisite for such a telescope as I have constructed, and shall describe, can be purchased of an optician by those who live in large cities; those who reside at a distance may have them sent by mail at a trifling additional cost. They are: 1. An achromatic object-glass, one and a half inches in diameter, with a focus of thirty inches. 2. Two plano-convex lenses of the respective foci of two inches and three fourths of an inch. The object-glass will cost about two dollars, and the other two lenses about seventy-five cents each.

Now procure a *straight* cylindrical roller of pine, one and five eighths inches in diameter, and thirty inches long; procure also a roller seven eighths of an inch in diameter, and fifteen or sixteen inches long. These are for forming the tubes on. Take stout brown wrapping paper, and, with bookbinder's paste, form a tube, twenty-nine inches long, on the large roller. Spread the paste on evenly, and rub the several layers of paper down smoothly with a cloth. Nine or ten thicknesses of paper will form a tube sufficiently thick and firm for our purpose; but only three or four layers should be laid at one time, and, when these are dry, three or four more may be added; and so on, until the requisite thickness is attained. When thoroughly dry, which will be in three or four days, you will have a stiff, straight, and light tube, the ends of which must be neatly and *squarely* cut off with a sharp knife, so as to leave it, when finished, exactly twenty-eight inches long. With a bit of

* This description of a home-made telescope, which first appeared in No. 1, Vol. XXIV, of *Popular Science Monthly*, is reprinted here by the courteous permission of the publishers.

sponge tied on the end of a stick, and some common or India ink, black the whole inside of the tube and set it aside, on end, until the other parts are ready.

Next form a tube on the smaller roller, with only four or five thicknesses of paper, fifteen inches in length. *When this is dry*, proceed to form a third tube over this second one as a roller, using six or seven thicknesses of paper in its formation. This last is to be used as a draw-tube for focusing with, and must be cut neatly and squarely off at the ends to a length of fifteen inches. A portion of the inner tube on which this was formed will be required for the eye-piece, directions for making which I shall give further on. Blacken the insides of both tubes, and set them aside, on end.

One more tube is required, *viz.*, that in which the draw-tube shall slide. It needs to be only six inches long, but, in order to smooth working, should be lined inside with fine cloth or cotton velvet. Procure, therefore, a piece of black broadcloth, six inches long, and of sufficient width to fit easily and accurately around the draw-tube. Then, using the latter as a roller, first neatly fit the cloth thereon as a first layer; next paste or gum the back of the cloth, and, with this for the innermost layer, form a short tube, six inches long, with paper and paste, as before directed, using here not more than six thicknesses. The draw-tube will now be found to move easily and smoothly back and forth in this cloth-lined sheath; but, for fear that the gum or paste should have penetrated the cloth lining, and should stick the tube and its sheath together, it will be safer to draw them apart before drying, and thus save needless trouble and annoyance.

On comparing the external diameter of this sheath with the interior diameter of the large tube first made, it will be found that some packing is required to hold the former steadily and concentrically within the latter. Take, therefore, some three-quarter-inch strips of brown paper, and, having pasted them, wind around the sheath at each end, to form rings or collars of equal thickness, and large enough to fit snugly within the main tube. The appearance of the sheath when completed will be as shown in Fig. 1, where *a a* are the collars just described.

Now take the compound object-glass, consisting of a double-convex

crown-glass lens, *A* (Fig. 2), and a plano-convex flint-glass lens, *B*. They will come from the optician's shop separate, but loosely fitted into each other. Be careful to see that their several surfaces are bright and free from specks, and, in handling them, touch only their edges. Remember, also, that the double-convex lens must be *outside* when the telescope is fitted up. Have ready a strip of tissue paper, just the width of the thickness of the lenses at the edges; gum this

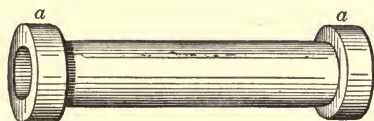

FIG. 1.

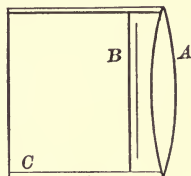

FIG. 2.

on one side, and, holding the two lenses together with the fingers of the left hand, wind the strip around the edges, so as to fix them together, and thus make a single piece which can be easily handled. When this is dry, take a strip of brown paper one and a quarter inches wide, and with paste form a short tube or cell, *C*, around the object-glass, using (say) five thicknesses. Fig. 2 shows the object-glass and cell in section.

To form the eye-piece: cut off a portion of the smallest tube—that on which the draw-tube was rolled—one and three eighths inches in length, and make the ends even and *square*. Make, now, two disks of blackened cardboard, of the diameters, respectively, of seven eighths inch and one inch. Punch or cut out exactly in the centre of each disk an aperture one quarter inch in diameter. Gum the edges of the smaller disk and fit it *into* the tube, exactly three quarters of an inch from one end, and, of course, five eighths of an inch from the other end. Then take the two-inch plano-convex lens, and, having made it perfectly clean, cement it on to the end of the tube nearest the perforated disk, with the plane surface inward. Use shellac varnish, or gold-size, for cementing the lens on to the edge of the tube. Cement the three-quarters-inch plano-convex on to the one-inch perforated disk, centrally over the aperture, and with the plane surface next the card. When the cement

on both lenses is dry, which will be in a day or two, fasten this one-inch disk to the open end of the tube, *keeping the lens inside*. A single layer of tissue paper, gummed on to the outside of the tube, and turned down about one sixteenth of an inch all around the edge of the two-inch lens, and around the disk at the other end, will now serve as a sort of fastener to both, and will complete the eye-piece, which is shown in full size in section, Fig. 3. The smaller lens *a* must be next the eye when the telescope is fitted up; the larger lens *b*, called the field-glass, will be inside and facing the object-glass.

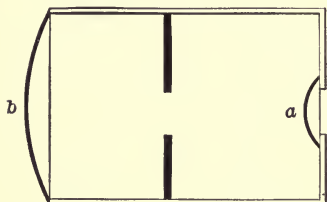

FIG. 3.

For fitting together the various parts now completed, few directions are needed. The cell containing the object-glass must first be slid into one end of the large tube, and made to fit neatly, by *even-wrapping* with tissue paper or other soft material. The sheath (Fig. 1) must now be slid into the other end of the large tube, and fitted in a similar manner. Now push the draw-tube into the sheath, and slide the eye-piece about halfway into the end of the draw-tube, and the telescope is completed. Those who are æsthetically inclined may give an extra finish to the main tube, and also to the draw-tube and eye-piece, by using for the outermost layers gilt paper, or other smooth and colored material. A sunshade, consisting of a wide tube, six inches long, may also be made to slide over the object end of the telescope; and a cap may be added to this to keep out dust. A kind of cap, perforated with an aperture one quarter of an inch in diameter, may also be constructed for slipping over the eye-piece, so as to preserve the proper distance between the eye and the eye lens when making observations; and a second similar cap should be made, and furnished with a disk of black or red glass, for protecting the eye when viewing the sun. For myself, I use a disk of thin microscopic glass, smoked and fastened in a cap which slips over the eye-piece.

But a telescope, even such as I have described, and which has a power of only twenty-five or twenty-six diameters, needs a stand, and this can be constructed easily and cheaply of one-inch pine and

a few nails and screws, something after the pattern shown in Fig. 4. By laying the telescope on the two end supports $Y Y'$, greater steadiness is secured than by using a single support in the centre; and the rods $y y'$ are easily raised or lowered and may be fixed in their positions by the little wedges $w w'$. The stand is thirty inches high, sixteen inches broad, and twenty-five inches long. The rods $y y'$ are forty inches and sixty inches long, respectively.

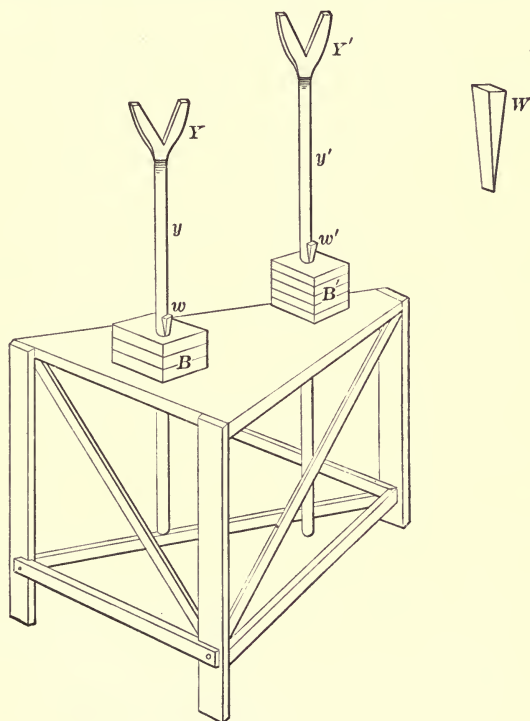

FIG. 4.

The blocks $B B'$ are built up of pieces of one-inch board nailed together; then an auger hole is bored through the whole, so as to form a sheath or tube in which the rods may slide easily, but without so much lateral motion, or "wobble," as they would have if they only passed through one thickness of board.

APPENDIX B.

SUGGESTIONS TO OBSERVERS OF THE ZODIACAL LIGHT.

BY PROFESSOR ARTHUR SEARLE OF HARVARD COLLEGE OBSERVATORY.

No instruments have as yet been brought into use in observing the zodiacal light, and all the methods employed in such observations are very simple. Any one who is interested in the subject, therefore, may advantageously undertake observations of the zodiacal light, which will probably be of value, even if they are not long continued, provided that sufficient care is taken in making and in recording them. Still, their value will be considerably increased if they form a continuous series extending over some years. Although not easy, the work may be recommended to such students as wish, while exercising themselves in practical astronomy, actually to add to our existing stock of knowledge.

The most convenient way of recording observations of the zodiacal light is usually found to be the representation of portions of it by drawing lines upon a chart of the sky. The "Atlas Coelestis Eclipticus" of Heis, published at Cologne in 1878 (a different work from the "Atlas Coelestis Novus," by the same author), was intended for this purpose and is well adapted to it. The Atlas contains eight charts covering the region of the zodiac, but without indicating the precise course of the ecliptic, in order to avoid any possible prejudice on the part of the observer. Whatever Atlas may be used, its name, and the epoch for which it gives the right ascensions and declinations of the stars, should form a part of the record of the observations. The epoch adopted by Heis is 1855.

Each observation, of course, will generally require a separate chart. One method of satisfying this want is to provide a large number of copies of each of the original charts by means of one of the various contrivances for copying which have been brought into use in recent times. In the absence of such a supply of copies a

piece of tracing paper should be laid upon the original chart, and fastened or firmly held so that it cannot shift its position while the lines forming the record of the observation are drawn upon it. The places of two or three of the stars shown upon the chart should be marked upon the tracing paper before it is removed from the chart, and the names of these stars should form part of the record. Afterwards, at the earliest convenient time, the drawing should be replaced upon the chart in its original position, in order to complete it by the insertion of additional stars, or of the hour-circles and parallels of declination for the epoch to which the chart relates.

Hitherto the principal observers of the zodiacal light have attempted to represent it by drawing upon their charts what they regarded as its outline. But since the light fades away very gradually towards its limits, different observers will probably differ considerably in their judgments with regard to the outline to be drawn, so that their drawings cannot satisfactorily be compared with each other. Even the same observer may at different times form various opinions as to the place of the outline. A more exact definition of the lines to be drawn is therefore desirable. A line at all points of which the sky appears to have the same degree of brightness may be called a contour line, and a line drawn upon the chart to represent a contour line will furnish a more instructive record than one understood merely to be an outline. When two observers are at work together, it is desirable for them to agree upon some point, such as that halfway between two stars not very far apart upon the chart, as one of the points of the proposed contour line. They should then, without further consultation, attempt to form wholly independent judgments with regard to the course of the line, and finally mark it upon their charts. It will be best for them not to compare the resulting drawings at once, but rather to defer the comparison to the next day, or even until all the drawings for the entire season have been completed, so that the independence of their work may not be affected by such a comparison.

It is not practicable, in drawing a contour line, to lay down a small portion of it upon the chart, and then look again at the sky to decide upon the next portion. The necessary use of artificial light in making the drawing will incapacitate the eye, for a few

minutes at least, for resuming the observation to any good purpose. Accordingly, if the place of the entire contour line cannot be fixed in the mind well enough to allow it to be drawn all at once, as large a portion as proves to be practicable should be observed and drawn, after which the eye should be rested until its power is fully restored. It may often be advisable to employ a fresh chart for the continuation of the line.

The observer should not be too hasty in deciding upon the course of the line he wishes to represent; but there is also a danger in delaying his decision until his eye has become fatigued and his mind perplexed. He should not ordinarily attempt to follow out all the possible sinuosities of the line, but should rather endeavor to determine its general course. If this is very difficult, it is probable that the degree of light which he has undertaken to represent is too faint; that is, that his contour line is too far from the central and brighter portion of the zodiacal light to be successfully traced out. It is desirable that the drawing should represent the contour line as it existed, not perhaps at a given minute, which would hardly be possible, but at least during a given ten minutes; and the time to which the drawing relates should always be recorded with at least that degree of accuracy.

The value of the observation will be materially increased if the degree of light represented by the contour line can be defined as equal to that of some small region of the sky at a distance from the zodiacal light. This region will naturally be one in or near the Milky Way. An actual example of such a comparison will illustrate this process. At Strafford, Vermont, at 3^h 40^m A.M. (eastern civil time) on the morning of Sept. 11, 1893, the point selected by two observers as one through which a contour line of the zodiacal light should be drawn was that halfway between ι and ϵ Cancri. According to one of the observers, the light at this point was equal to that three tenths of the way from ζ Tauri to θ Aurigæ; according to the other, it was equal to that halfway from α Aurigæ to η Aurigæ. The contour lines drawn by the observers, although necessarily coincident at the selected point, deviate from each other in places as much as five degrees. Observers should not be discouraged by discrepancies of this kind, for until it is known how much

difference may be expected between results obtained at the same place and time, it is evident that we shall have little satisfaction in comparing observations made at different stations and in different years.

The sky in the immediate vicinity of a star can be taken as a standard of comparison, or as a point defining a contour line, only in case the star is faint. A star of the third magnitude, or a brighter one, will hinder the observer by its brightness from estimating the light of the sky at the point which it occupies and for a larger or smaller region around it, according to circumstances.

A number of contour lines, representing different degrees of brightness, will furnish a more satisfactory representation of the zodiacal light on a given date than can be obtained by one alone; but a single observation, carefully made and recorded, will be of more service than a greater number of defective records. Observers may often find it best to begin with single observations and to increase the number of their drawings on the same evening, after they have gained confidence and can do the work more rapidly than at first, without loss of precision.

Besides contour lines, others may often be drawn with advantage; but they should be carefully distinguished from contour lines in the record of the observations. At any given elongation from the sun the ordinary zodiacal light increases in brightness from either of its borders toward its middle, so that a maximum of light for that particular elongation can be observed, although its place cannot be estimated with much precision. A line drawn through the successive maxima at different elongations may be called the axis of brightness of the zodiacal light. It is not a contour line, since these maxima are brighter at small than at great elongations; but if a line representing it can be drawn upon the chart, it is well to do so. Again, various observers have thought that they could distinguish between an inner and an outer cone of zodiacal light. If such an appearance presents itself, the boundary of the inner cone may properly be drawn, even if it is not a contour line. The record should, of course, contain a clear statement of what was intended by the observer.

It has been thought, especially by some of the earlier observers of

the zodiacal cone, that the position of its vertex was one of its most important features. But this vertex, owing to the faintness of the light at so great an elongation, and its very gradual diminution in brightness, cannot ordinarily be determined by the observer. If, however, he can recognize its existence, he will do well to draw a contour line passing through it.

The zodiacal light in its ordinary conical form, to which all the preceding suggestions relate, is an object easily recognized after a little experience has been gained, and can seldom be confounded with light resulting from some other cause. But this is not the case when the observer undertakes the study of the fainter portions of the light, such as those near or beyond what would ordinarily be taken for its vertex. Faint bands, resulting from aggregations of small stars, may be taken for zodiacal light in the special sense of that term; so, too, may the comparatively steady portions of auroral bands and streamers, which not seldom appear in the zodiac. To distinguish between light in the zodiac, in general, and zodiacal light in particular is an interesting work, but demands more time than can usually be given to the subject. Any observer having the required time at his disposal will best succeed in making his conclusions independent, by avoiding too minute acquaintance with those of previous inquirers. Any light which he studies may be defined as well as possible by contour lines, as above explained, and by degrees he will acquire the means of distinguishing between the permanent features of the sky in and near the zodiac, the merely temporary phenomena which may be ascribed to a common source with the aurora, and other appearances which he may think it most reasonable to regard as connected with the more familiar form of the zodiacal light.

One of these last appearances, however, seems now to have been so much observed that its reality can hardly be doubted. It is usually called *Gegenschein*, although the English word, "Counter-glow," has also been proposed as an equivalent for the original German term. It consists of a faint light seen at or near that place in the sky which is at the time in opposition to the sun. Hence it can best be seen about midnight, although observers having the advantage of an unusually transparent atmosphere have been able to

observe it comparatively early in the evening. Observations of it may be recorded by means of contour lines, and also by a verbal statement showing the place of its centre, or brightest part, with respect to adjacent stars; for example, "halfway from δ Piscium to 29 Ceti," or, on another occasion, "halfway from δ Piscium to a point two thirds of the way from 20 Ceti to f Piscium." Such descriptions should subsequently be reduced, by means of the places of the designated stars, to right ascension and declination for a given epoch. The reduction to celestial longitude and latitude should not be made by the observer during the continuance of his work for any particular season, and, if made by others, he should not be informed of the result at the time, so that the independence of his next observations may not be affected.

In all this work, as indeed in all astronomical observation, careful attention to the completeness and clearness of the record in all respects, such as place, time, epoch of chart employed, the observer, and his exact intention in making each line of his drawing, will secure the subsequent use of much work which would otherwise be found valueless to future students.

APPENDIX C.

A SHORT METHOD OF FINDING THE TIME WHEN THE MOON RISES AND SETS.

BY PROFESSOR EDGAR FRISBY, U. S. N.

THE times when the moon rises and sets are conveniently computed by means of the semi-diurnal arcs for the sun. The values of δ between 0° and 29° should be included so as to provide for all variations in the moon's declination. These arcs should be calculated at least for whole degrees, and if great accuracy is required, for every $10'$.

It is customary to compute the semi-diurnal arcs for the upper limb, including refraction $35'$ and semi-diameter $16'$, making the actual zenith distance of the sun's centre $90^\circ 51'$ at the time of visible rising or setting. By means of the ordinary spherical triangle between the zenith, the pole and the sun's upper limb at rising or setting, we have the relation

$$\cos z = \sin \delta \sin \phi + \cos \delta \cos \phi \cos t = \cos(90^\circ 51') = -\sin 51',$$

from which we immediately deduce the equations

$$\cos t = -\tan \delta \tan \phi \left(1 + \frac{\sin 51'}{\sin \delta \sin \phi}\right) \text{ for Sun North}$$

$$\cos t = \tan \delta \tan \phi \left(1 - \frac{\sin 51'}{\sin \delta \sin \phi}\right) \text{ for Sun South.}$$

The declinations in these formulæ and those following are used numerically, as though they were all positive.

In the case of the moon it is usual to allow for refraction and compute for the centre, in which case we have, calling the parallax π ,

$$\cos(90^\circ 35' - \pi) = \sin \delta \sin \phi + \cos \delta \cos \phi \cos t.$$

Giving π the two values $86'$ and $35'$, we have :

$$\cos(89^\circ 9') = \sin \delta \sin \phi + \cos \delta \cos \phi \cos t = -\cos(90^\circ 51') = \sin 51'$$

$$\cos 90^\circ = \sin \delta \sin \phi + \cos \delta \cos \phi \cos t = 0$$

$$\cos t = -\tan \delta \tan \phi \left(1 - \frac{\sin 51'}{\sin \delta \sin \phi} \right) \quad (1), \quad \text{for parallax } 86', \text{ and Moon N.}$$

$$\cos t = \tan \delta \tan \phi \left(1 + \frac{\sin 51'}{\sin \delta \sin \phi} \right) \quad (2), \quad \text{for parallax } 86', \text{ and Moon S.}$$

$$\cos t = -\tan \delta \tan \phi \quad (3), \quad \text{for parallax } 35', \text{ and Moon N.}$$

$$\cos t = \tan \delta \tan \phi \quad (4), \quad \text{for parallax } 35', \text{ and Moon S.}$$

In order to obtain the necessary tables, we compute the following quantities with different values of δ , using addition and subtraction tables for (6) and (7) :

$$\tan \delta \tan \phi \quad (5)$$

$$\log \left(1 + \frac{\sin 51'}{\sin \delta \sin \phi} \right) \quad (6)$$

$$\log \left(1 - \frac{\sin 51'}{\sin \delta \sin \phi} \right) \quad (7)$$

$$\cos t = -\tan \delta \tan \phi \left(1 + \frac{\sin 51'}{\sin \delta \sin \phi} \right) \quad (8)$$

$$\cos t = \tan \delta \tan \phi \left(1 - \frac{\sin 51'}{\sin \delta \sin \phi} \right) \quad (9)$$

The connection between formulæ (5), (8), and (9) and those above numbered (1), (2), (3), and (4) is readily seen to be

$$(1) = 12^h - (9) \qquad (2) = 12^h - (8)$$

$$(3) = 12 - (5) \qquad (4) = (5)$$

If for the present the moon's motion in right ascension is neglected, the lunar arcs for rising and setting of the centre may be deduced immediately from the solar semi-diurnal arcs, including parallax.

So far we have considered formulæ only for parallax $86'$ and $35'$; but expressions applicable for $60'.5$ may be obtained by combining thus :

$$\text{Moon North } \frac{(1) + (3)}{2}$$

$$\text{Moon South } \frac{(2) + (4)}{2}$$

A complete table can now be easily formed by interpolating for other values of parallax, say from $54'$ to $61'$, proceeding by $1'$ if it is thought necessary; and after tables have been computed once for all, the process of finding the time when the moon rises or sets on any day becomes simply a matter of interpolation.

The following directions give in detail the different steps required after the calculation of the preliminary tables :

1. From the Washington time of transit given in the Ephemeris and the difference for one hour of longitude, find the local time of transit.

2. Reduce this time to Greenwich time.

3. From the declination and tables guess the approximate time of rising or setting, accounting for change of right ascension if possible.

4. For this time take out the parallax, and for the mean time between meridian passage and rising or setting take out the "difference" in time of transit for 1^h of longitude.

5. From declination derived from time in 3, take out hour-angle from tables and multiply difference for 1^h by this hour-angle expressed in hours and decimals of an hour.

6. Add this motion to the hour-angle; then add the resulting sum to, or subtract it from, the Greenwich time for setting or rising.

7. See if this agrees with the assumed Greenwich time; if not, repeat the process.

8. Reduce the final Greenwich time to local time.

It should be noted that the difference in the tables for $1'$ of δ is scarcely ever much greater than 4^s , that is, $15'$ gives a difference of 1^m ; and the moon never moves more than $15'$ in declination during an hour of time; therefore, we may make a mistake of 1^h in assuming the time of rising or setting without even affecting our results by as much as 1^m ; and if the declination is changing very slowly, we may assume almost anything without sensibly affecting the results.

EXAMPLE 1. — Compute the time of moonrise for Washington on the morning of June 2, 1896.

| | | |
|---|----------------------|-----------------------------------|
| Washington time of transit, June 1, 17 ^h 31 ^m 40 ^s | Approx. Decl. | = -12° |
| Greenwich time of transit, June 1, 22 39 52 | Approx. hour-angle | = -5 ^h 20 ^m |
| Assumed Greenwich time of rising, 17 10 | $1^m.74 \times 5.33$ | = <u>9</u> |
| Corres. δ , Gr. Ephem., - 11° 24'.6, | | -5 29 |
| Hour-angle corres. to δ , - 11° 24'.6, - 5. 20 40 | Parallax | = 55'.0 |
| | Hourly motion | = 1 ^m .74 |
| Corrected hour-angle, - 5 29 57 | $1^m.74 \times 5.34$ | = 9 ^m 17 ^s |
| Greenwich time of rising, 17 9 55 | | |
| Washington time of rising, June 1, 12 1 43 | Astronomical date. | |
| Washington time of rising, June 2, 0 1 43 | A. M., Civil date. | |

Since the latter Greenwich time agrees with that first assumed, 17^h 10^m, there is no need of repetition.

EXAMPLE 2. — Find the time of moonrise at Washington on the morning of June 6, 1896.

| | | |
|---|---------------------------|------------------------------------|
| Washington time of transit, June 5, 20 ^h 10 ^m 51 ^s | Approx. Decl. | = + 10° |
| Greenwich time of transit, June 6, 1 19 3 | Approx. hour-angle | = - 6 ^h 31 ^m |
| Assumed Gr. time of rising, June 5, 18 37 | 1 ^m .71 × 6.5 | = <u>11</u> |
| Corres. δ , Gr. Ephem., 10° 40'.7, | | - 6 42 |
| Hour-angle corres. to δ , 10° 40'.7, - 6 33 11 | Parallax | = 54'.3 |
| | Hourly motion | = 1 ^m .71 |
| Corrected hour-angle, - 6 44 23 | 1 ^m .71 × 6.55 | = 11 ^m 12 ^s |
| Greenwich time of rising, 18 34 40 | | |
| Washington time of rising, June 5, 13 26 28 | Astronomical date. | |
| Washington time of rising, June 6, 1 26 28 | A.M., Civil date. | |

Assuming the final Greenwich value, 18^h 34^m 40^s, and repeating the process, we obtain a correction of only 1^s.

EXAMPLE 3. — Find the time when the moon sets at Washington June 13, 1896.

| | | |
|---|---------------------------|-----------------------------------|
| Washington time of transit, June 13, 2 ^h 11 ^m 16 ^s | Approx. Decl. | = + 23° |
| Greenwich time of transit, June 13, 7 19 28 | Approx. hour-angle | = 7 ^h 17 ^m |
| Approx. Gr. time of setting, June 13, 14 54 | 2 ^m .29 × 7.3 | = <u>17</u> |
| Corres. δ , Gr. Ephem., 23° 7'.7, | | 7 34 |
| Hour-angle corres. to δ , 23° 7'.7, 7 18 6 | Parallax | = 57'.7 |
| | Hourly motion | = 2 ^m .29 |
| Corrected hour-angle, 7 34 49 | 2 ^m .29 × 7.30 | = 16 ^m 43 ^s |
| Greenwich time of setting, 14 54 17 | | |
| Washington time of setting, 9 46 5 | | |

If we have computed two or three consecutive risings or settings, we can extrapolate and guess the approximate hour-angle very closely.

In the examples given above, the motion in right ascension has been taken into account in the correction which is added in each case to the hour-angle.

APPENDIX D.

HOUR-ANGLES OF THE MOON ON THE HORIZON.

LATITUDE 42° 19'.

| MOON NORTH. | | | | | MOON SOUTH. | | | | |
|-------------|-----------|-------|-------|-------|-------------|-----------|-------|-------|-------|
| DECL. | PARALLAX. | | | | DECL. | PARALLAX. | | | |
| | 55' | 57' | 59' | 61' | | 55' | 57' | 59' | 61' |
| | 6h | 6h | 6h | 6h | | 5h | 5h | 5h | 5h |
| | m s | m s | m s | m s | | m s | m s | m s | m s |
| +6°.0 | 20 8 | 19 57 | 19 46 | 19 36 | -13°.0 | 9 34 | 9 23 | 9 12 | 9 0 |
| 6.5 | 22 0 | 21 49 | 21 38 | 21 28 | 13.5 | 7 35 | 7 24 | 7 13 | 7 1 |
| 7.0 | 23 50 | 23 39 | 23 28 | 23 18 | 14.0 | 5 35 | 5 24 | 5 13 | 5 1 |
| 7.5 | 25 42 | 25 31 | 25 20 | 25 10 | 14.5 | 3 35 | 3 23 | 3 12 | 3 0 |
| 8.0 | 27 34 | 27 23 | 27 12 | 27 2 | 15.0 | 1 35 | 1 23 | 1 12 | 1 0 |
| | 7h | 7h | 7h | 7h | | 4h | 4h | 4h | 4h |
| | m s | m s | m s | m s | | m s | m s | m s | m s |
| +20.0 | 15 23 | 15 11 | 14 59 | 14 46 | -15.5 | 59 34 | 59 22 | 59 11 | 58 59 |
| 20.5 | 17 34 | 17 22 | 17 9 | 16 57 | 16.0 | 57 31 | 57 19 | 57 8 | 56 56 |
| 21.0 | 19 46 | 19 34 | 19 21 | 19 9 | 16.5 | 55 27 | 55 15 | 55 3 | 54 52 |
| 21.5 | 22 0 | 21 48 | 21 35 | 21 23 | 17.0 | 53 23 | 53 11 | 52 59 | 52 48 |
| 22.0 | 24 14 | 24 1 | 23 49 | 23 36 | 17.5 | 51 17 | 51 5 | 50 53 | 50 42 |
| 22.5 | 26 31 | 26 18 | 26 6 | 25 53 | 18.0 | 49 10 | 48 58 | 48 46 | 48 34 |
| 23.0 | 28 50 | 28 37 | 28 25 | 28 12 | 18.5 | 47 3 | 46 51 | 46 39 | 46 27 |
| +23.5 | 31 9 | 30 56 | 30 43 | 30 31 | -19.0 | 44 54 | 44 42 | 44 30 | 44 18 |
| 24.0 | 33 31 | 33 18 | 33 5 | 32 53 | 19.5 | 42 44 | 42 32 | 42 20 | 42 7 |
| 24.5 | 35 53 | 35 40 | 35 27 | 35 14 | 20.0 | 40 33 | 40 21 | 40 9 | 39 56 |
| 25.0 | 38 19 | 38 6 | 37 53 | 37 40 | 20.5 | 38 21 | 38 9 | 37 56 | 37 44 |
| 25.5 | 40 45 | 40 32 | 40 19 | 40 5 | 21.0 | 36 6 | 35 54 | 35 41 | 35 29 |
| 26.0 | 43 13 | 43 0 | 42 46 | 42 33 | 21.5 | 33 51 | 33 38 | 33 26 | 33 13 |
| 26.5 | 45 45 | 45 32 | 45 18 | 45 5 | 22.0 | 31 34 | 31 21 | 31 9 | 30 56 |

APPENDIX E.

LATITUDES AND LONGITUDES OF PLACES MENTIONED IN THE TEXT.

| PLACE. | LATITUDE. | LONGITUDE. | AUTHORITY. |
|------------------------|-------------|--|---|
| Ann Arbor, Mich. | + 42° 16'.8 | + 5 ^h 34 ^m 55 ^s | American Ephemeris |
| Arequipa, Peru | - 16 24 | + 4 45 30 | “ “ |
| Augusta, Me. | + 44 18.9 | + 4 39 6 | American Navigator |
| Baltimore, Md. | + 39 17.5 | + 5 6 27 | U. S. Geological Survey |
| Boston, Mass. | + 42 21.5 | + 4 44 15 | American Navigator |
| Charlottesville, Va. | + 38 2.0 | + 5 14 5 | American Ephemeris |
| Cleveland, O. | + 41 30.1 | + 5 26 49 | U. S. Geological Survey |
| Detroit, Mich. | + 42 20 | + 5 32.2 | Smithsonian Meteorologi- cal Tables |
| Galveston, Tex. | + 29 18.3 | + 6 19 10 | American Navigator |
| Hartford, Conn. | + 41 45.6 | + 4 50 42 | U. S. Geological Survey |
| Havana, Cuba | + 23 9.4 | + 5 29 26 | American Navigator |
| Honolulu, Hawaii | + 21 17.9 | + 10 31 28 | “ “ |
| Key West, Fla. | + 24 33.4 | + 5 27 14 | “ “ |
| Lawrence, Kan. | + 38 57.5 | + 6 20 58 | U. S. Geological Survey |
| Lick Observatory, Cal. | + 37 20.4 | + 8 6 35 | American Ephemeris |
| Montreal, Canada | + 45 30.3 | + 4 54 19 | “ “ |
| Moscow, Russia | + 55 45.3 | - 2 30 17 | “ “ |
| Nashville, Tenn. | + 36 8.9 | + 5 47 12 | “ “ |
| New Orleans, La. | + 29 57.8 | + 6 0 14 | American Navigator |
| New York, N. Y. | + 40 45.4 | + 4 55 54 | American Ephemeris |
| Northfield, Minn. | + 44 27.7 | + 6 12 36 | “ “ |
| Northampton, Mass. | + 42 19.0* | + 4 50 33 | Longitude, Harvard An- nals, Vol. XXIX |
| Omaha, Neb. | + 41 15.7 | + 6 23 43 | Encyclopædia Britannica |
| Oxford, Miss. | + 34 22.2 | + 5 58 7 | American Ephemeris |
| Philadelphia, Penn. | + 39 57.1 | + 5 0 38 | “ “ |
| Portland, Me. | + 43 37.4 | + 4 40 50 | U. S. Geological Survey |
| Portland, Ore. | + 45 32 | + 8 10.9 | Smithsonian Meteorologi- cal Tables |
| Quito, Peru | - 0 14.0 | + 5 15 20 | American Ephemeris |
| Raleigh, N. C. | + 35 47 | + 5 15.2 | Encyclopædia Britannica |
| Rio de Janeiro, Brazil | - 22 54.4 | + 2 52 41 | American Ephemeris |

* From the unpublished value determined at Smith College Observatory.

| PLACE. | LATITUDE. | LONGITUDE. | AUTHORITY. |
|----------------------|-------------|--|----------------------------|
| Salt Lake City, Utah | + 40° 46'.1 | + 7 ^h 27 ^m 35 ^s | U. S. Geological Survey |
| San Francisco, Cal. | + 37 47.5 | + 8 9 43 | American Ephemeris |
| Santa Fé, N. M. | + 35 41.1 | + 7 4.1 | Loomis Practical Astronomy |
| Savannah, Ga. | + 32 4.9 | + 5 24 22 | American Navigator |
| Stockholm, Sweden | + 59 20.6 | - 1 12 14 | American Ephemeris |
| Utica, N. Y. | + 43 6.1 | + 5 0 56 | U. S. Geological Survey |
| Washington, D. C. | + 38 55.2 | + 5 8 16 | American Ephemeris |



APPENDIX F.

ASTRONOMICAL FORMULÆ EMPLOYED IN THE TEXT.

FORMULA FOR GRADUATING A SUN-DIAL.

$$\tan A = \tan t \sin \phi \quad (1) \quad \S 17$$

FORMULA FOR REDUCING ANY INTERVAL OF TIME TO AN EQUATORIAL INTERVAL.

$$i = I \cos \delta \quad (2) \quad \S 20$$

FORMULÆ FOR FINDING HOUR-ANGLE AND DECLINATION.

$$\cos t = -\tan \phi \tan \delta \quad (3) \quad \S 40$$

$$\sin \delta = -\cos \phi \cos A$$

$$\cos t = \sin \phi \cos A \sec \delta \quad (4) \quad \S 40$$

$$\sin t = \sin A \sec \delta$$

$$m \cos M = \cos \zeta$$

$$\tan M = \tan \zeta \cos A$$

$$\tan t = \frac{\tan A \sin M}{\cos(\phi - M)} \quad (5) \quad \S 40$$

$$\tan \delta = \tan(\phi - M) \cos t$$

$$\sin \frac{1}{2} t = \sqrt{\frac{\sin \frac{1}{2} [\zeta + (\phi - \delta)] \sin \frac{1}{2} [\zeta - (\phi - \delta)]}{\cos \phi \cos \delta}} \quad (6) \quad \S 40$$

FORMULÆ FOR FINDING AZIMUTH AND ZENITH DISTANCE.

$$\sin a = \sec \phi \sin \delta \quad (7) \quad \S 75$$

$$\cos \frac{1}{2} A = \sqrt{\frac{\cos \frac{1}{2} [\zeta + (\phi + \delta)] \sin \frac{1}{2} [\zeta + (\phi - \delta)]}{\sin \zeta \cos \phi}} \quad (8) \quad \S 75$$

$$\left. \begin{aligned} m \sin M &= \sin \delta & \tan A &= \frac{\tan t \cos M}{\sin(\phi - M)} \\ \tan M &= \frac{\tan \delta}{\cos t} & \tan \zeta &= \frac{\tan(\phi - M)}{\cos A} \end{aligned} \right\} (9) \quad \S 75$$



INDEX.

(All references are to *sections*, not to *pages*.)

- Algol, minimum of, 206.
- Almanac, common, adapted for different places, 42-3; compared with Ephemeris, 33, 46.
- Nautical, see Ephemeris.
- Old Farmer's, tabular corrections, 43; compared with Jayne's, 37, 46 Ex. 4.
- See also Chapter III.
- Altazimuth, see Circles.
- Altitude, observed, of moon, planet, and star, 134; of sun, 100-103, 116; of sun, from shadows, 100, 116.
- Theoretical, from almanac, 32; from globe, 74; from trigonometry, 75, 103.
- Trigonometrical formulæ for, 75, Appendix F.
- Altitudes, tables of, 103, 107, 134.
- Amplitude, definition, 75; of sun from shadow of tree, 100.
- See also Azimuth.
- Angle between moon's horns and horizon, 142.
- Angles, measuring units for, 6.
- Angular distance, see Distance.
- Apparent time, 34, 38; compared with mean, 36; with standard, 37, 50.
- From observation, see Time.
- Argelander's method for observing variable stars, 205.
- Astronomical day, 33.
- Azimuth, observed, of moon, planet, and star, 134; of sun at setting, 104; of sun at any hour, 100, 105; of sun from shadow of tree, 100; at rising or setting for a body above the horizon, 107, 134.
- Theoretical, from globe, 74; from trigonometry, 75, 105.
- Trigonometrical formulæ for, 75, Appendix F.
- Azimuth stand, 15.
- Azimuths, tables of, 105, 107, 134.
- Bonn Durchmusterung Charts, 57, 212, 221.
- Brahe, Tycho, cross-staff, 14.
- Brightness, of Mars, variation in, 168.
- Of stars, see Variable stars.
- Cardinal points, from observation, 9, 191.
- In the heavens, 7.
- Cassiopeiæ, β , time from, 197.
- Catalogue stars identified, 57, 167.
- Ceti, α , maximum of, 207.
- Chandler, S. C., "Catalogue of Variable Stars," 205.
- Circles, description, 16; adjustment and use, 101 Obs. 3, 107, 113 Obs. 2.
- Civil and astronomical days, 33.
- Clock error, sign for, 69.

- Comet *b*, 1898, appearance and motion, 222; Encke's, diurnal path from globe, 84.
- Conjunction, of Mars and the moon, 169; Mars and η Cancri, 170; Mercury and Venus, 163.
- Inferior, of Venus, 165.
- Constellations traced, 192; motion of, with regard to the horizon, 193.
- Corrections for Old Farmer's Almanac, 43.
- Cross-staff, description, 14; observation with, 174.
- Day, civil and astronomical, 33; sidereal and mean solar, 203.
- Length of, from observation, 109; from calculation, 109; for different latitudes and seasons, from globe, 80.
- Declination, estimated directly, 174; from altitude and azimuth, 202; from star-maps, 56.
- Variation in, affecting hour-angles, 41.
- Diameter of sun from field of view of telescope, 214.
- Dipper, motion of, 193.
- Distance between celestial objects, from observation, 163-5, 169-70; from globe, 72; from trigonometry, 72 Ex. 3.
- Measuring units for, 6.
- Double stars with small telescope, 223; with opera-glass, 204.
- Earth's shadow, 121.
- Eclipse of moon, total, 149; partial, 218; of sun, partial, 123.
- Time of phases of lunar, 47.
- Ecliptic, diurnal motion of, 194; inclination of, from observation, 117; effect of inclination, on equation of time, 77.
- Elongation of Venus, maximum, 164; near inferior conjunction, 165.
- Encke's comet, diurnal path, from globe, 84.
- Ephemeris, American, and Nautical Almanac, equation of time, 50; hourly motion of the moon, 135; mean and sidereal time, 51-3; parallax of moon, 136, 145; paths of Mars and Jupiter, 171-2; planetary constellations, 163-4, 170; right ascension and declination of moon or sun for given hour, 44, 135-6; Tables II and III, 48; Table IV, 195 Obs. 2.
- Equation of time, 36, 50.
- Partial, from globe, 77.
- Equatorial interval formulæ, 20 d.
- Errors, accidental and systematic, 3.
- Evening star defined, 31.
- Formulæ, principal trigonometrical, used in the text, Appendix F.
- Frisby, E., "A Short Method of Finding the Time when the Moon Rises and Sets," Appendix C.
- Globe, oriented for latitude and for time, 68-9; location of celestial objects, 71; places of sun and stars verified, 71, 73.
- Use of, for altitude and azimuth, 74; cardinal points, 191; diurnal paths, 78-9, 82-4, 111, 139; distance between celestial objects, 72, 167, 169; equation of time, 77; graduating sun-dial, 76; hour-angles, 80, 85, 108, 196; identification of Mercury, 74-5, 161.
- Gnomon, description, 11; adjustment and use, 100, 101 Obs. 4, 112 Obs. 3, 116; height available, 11.
- Greenwich time, from local or standard, 49.

- Halo around the moon, 150.
- Heliotellus, synodic period of Venus from, 86.
- Hour-angles, affected by latitude and longitude, 41; connection with sidereal time, 39; from semi-diurnal arcs, 40, 108, 136.
- Observed, of circumpolar stars, 196-7.
- Trigonometrical formulæ for, 40, Appendix F; from altitude, 108, 145; from azimuth, 108, 135; from altitude and azimuth, 113 Obs. 2, 137.
- See also Time.
- Hunter's moon, 139.
- Identification, of lunar objects, 216; of Mercury, 161; of Uranus, 175; of Vesta, 221.
- Inclination of ecliptic, from observation, 117; effect on equation of time, 77.
- Jupiter, in small telescope, 219-20; time from altitude and azimuth, 177; motion, compared with that of Venus, 167; path among the stars, 172.
- Satellites of, with opera-glass, 173; with small telescope, 220.
- Latitude, from altitude of stars, 195; from altitude of the sun, 114-6; at the equinoxes, 115; at the solstices, 116.
- Effect of, on diurnal paths, 79; on hour-angle and time of rising, 41-2, 85; on length of day, 80.
- Latitudes of places mentioned in the text, Appendix E.
- Leonids in 1898, 178.
- Local and standard time, 34-5.
- Longitude, of sun for given date, 71; of moon's terminator, 217.
- Terrestrial, connection with time, 34-5, 49-50; effect on hour-angles and time of rising of bodies, 41-2; for places mentioned in the text, Appendix E; found from moon's transit, 147.
- Lyra traced, 192.
- Magnitudes, comparative, see Variable stars.
- Map, of constellation Lyra, 192; lunar objects, 216; path of Jupiter, 172; path of Mars, 171; positions of Vesta, 221.
- Maps, catalogue stars identified on, 57; location of celestial objects on, 55, 167; right ascension and declination estimated from, 56, 171-2.
- See also Bonn Durchmusterung.
- Mars, appearance in small telescope, 219; conjunction with moon, 169; conjunction with η Cancri, 170; diurnal path represented graphically, 138; path among the stars, 171; variation in brightness, 168.
- Mean time, compared with apparent, 36, 38, 50; reduced to sidereal, 51, 53; derived from sidereal, rigorous method, 52-3; from sidereal, approximate method, 197.
- Loss of, on sidereal, 48; from observation, 203.
- Measuring circle for hour-angles of circumpolar stars, 196.
- Measuring units for distances and angles, 6.
- Mercury, appearance in small telescope, 219; conjunction with Venus, 163; identification, 161; time from altitude, 176.

- Meridian line, from North Star and plumb lines, 9 b; from shadow of plumb line, 9 c; from shadow of wall, 9 a.
- Milky Way, appearance in small telescope, 225; diurnal motion, 208.
- Mira, observations near maximum, 207; light curve, 207.
- Moon, declination and altitude on the meridian from Ephemeris, 32; conjunction with planet, 169; halo surrounding, 150; hunter's, 139; phases, 46; position of terminator, 217; rate of apparent and proper motion, 137; time from observed transit, 146; theoretical time of transit, 43 b, 45.
- Eclipse, partial, 218; total, 149; time of phases, 47.
- Horns of, with regard to the horizon, 142.
- Path, from globe, for different years, 81-2; in summer and winter, 83; diurnal, from observation, 134; represented graphically, 138.
- Periods, sidereal, 144; synodic, 143.
- Surface markings, with naked eye, 148; with small telescope, 216; map of, 216; sunrise on given formation, 217.
- See also Moonrise, Time, Longitude.
- Moonrise, from observation, 135, 139-41; in April, 140; in October, 139; when full, 141; from semi-diurnal arcs, 136, Appendixes C and D.
- Morning and evening stars, 31.
- Motion, diurnal, of dipper, 193; ecliptic, 194.
- Milky Way, 208.
- Rate of apparent, of sun, 110; apparent and proper, of moon, 137; of Venus and Jupiter among the stars, 167.
- Noon, apparent, observations for, 112; standard time of, 37.
- North Star, cardinal points and meridian line located from, 9 b, 191; celestial meridian fixed by, 198.
- Latitude from, on the meridian, 195 Obs. 2; not on the meridian, 195 Obs. 3.
- Numerical records, rules for, 5.
- Nyland, A. A., maximum of \circ Ceti, 207.
- Orientation of celestial globe, 68; check for, 69.
- Parallax of moon, corrections for, 136, 145.
- Parkhurst, H. M., maximum of \circ Ceti, 207.
- Path, among the stars, Mars's, from observation, 171; Jupiter's, from observation, 172; moon's, from Ephemeris and globe, 81.
- Diurnal, graphically represented, Fomalhaut, 138; Mars, 138; moon, 134, 138; sun, 106-7, 111; sun, without instruments, 106; Venus, 166; β Orionis, 166.
- From globe, Encke's comet, 84; moon, 81-3; moon in different years, 81-2; moon in summer and winter, 83; sun in different seasons, 78; sun in different latitudes, 79.
- Period, moon's sidereal, 144; moon's synodic, 143; sun's rotation, 215; Venus's synodic, from heliotelus, 86.
- Personal bias, 2.
- Phases, time of moon's, 46; of lunar eclipse, 47.
- Pickering, E. C., "Variable Stars of Long Period," 205.
- Place for observing, 9, 101, 107.

- Planetoid Vesta, identified, 221.
- Planets, face appearance to the naked eye, 160; appearance in a small telescope, 219; conjunctions, 163, 169, 170; diurnal paths, 138, 166; elongations, 164-5; location on star-maps, 55; paths among the stars, 171-2; times of transit from almanac, 38.
- See also individual names.
- Plumb lines, for finding meridian, 9; for finding time, 201.
- See also Transit Tube.
- Præsepe, with a small telescope, 224.
- Precession, computed, effect of, 57.
- Prime vertical from observation, 10.
- Protractors, description, 12; example of use, 102.
- Quadrants, description, 13; example of use, 101 Obs. 2.
- Recording, rules for, 5, 8.
- Refraction shown by sun-dial, 119; value at sunset, 40.
- Retrogression, arc of, Mars's, 171; Jupiter's, 172.
- Right ascension, estimated directly, 174; from altitude and azimuth, 202; read from star-maps, 56.
- Variation in, affecting times of rising, 42.
- Rising and setting, time of, from observation, moon, 135, 139-41; sun, 108.
- Theoretical, from almanac, 43 c; from globe, 85; from semi-diurnal arcs, 108, 136, Appendixes C and D; from trigonometrical formulæ, 41-2, 108.
- Rotation of sun determined from sun spots, 215.
- Rulers, jointed, description, 12; example of use, 102; with scale attached, see Quadrants.
- Rules for recording, 5, 8; for comparing star magnitudes, 205.
- Satellites of Jupiter with opera-glass, 173; with small telescope, 220.
- Saturn and its rings, in a small telescope, 219; right ascension and declination from observation, 174.
- Scale, home-made, for measuring diameter of emergent pencil of light, 20 c.
- Searle, A., "Suggestions to Observers of the Zodiacal Light," Appendix B.
- Season, effect of, on length of day, 80; on moon's path, 83; on sun's path, 78.
- Semi-diurnal arcs, moonrise from, 136, Appendix C; sunrise from, 108; table of moon's, Appendix D.
- Setting, of moon from semi-diurnal arcs, Appendix C, Ex. 3; of Pleiades, at Fargo and 15° south, 85 Ex. 2.
- See also Rising.
- Shadow of earth, 121.
- Shadow of plumb line for finding meridian, 9; position of sun, 100.
- See also Gnomon.
- Shooting stars observed, 178.
- Sidereal time, connection with hour-angle, 39; reduced to mean, rigorous method, 52-3; reduced to mean, approximate method, 197; derived from mean, 51, 53; gain of, on mean solar, 48; from observation, 203.
- From observation, see Time.
- Southing of heavenly bodies, from almanac, 38, 43 a; of moon, from its age, 45.
- See also Transit.

- Standard time reduced to apparent, 37, 50; to local and Greenwich, 34-5, 49.
- Star-cluster in small telescope, 224.
- Star, conjunction with a planet, 170; diurnal path, from observation, 138, 166; identification on star-map, 57; right ascension and declination from observed altitude and azimuth, 202; rising and setting, from globe, 85.
- See also Latitude, Stars, Time.
- Stars, double, 204; variable, 205-7.
- Steps in observing variable stars, 205, 207.
- Sun, angular diameter, 214; location on globe, 71; partial eclipse, 123; period of rotation from sun spots, 215; rate of apparent motion, 110; right ascension and declination from Ephemeris, 44.
- Altitudes observed, 100-103, 116; at noon, 101; at any hour, 102; from shadow of tree, 100; theoretical, 32, 103; at noon, 32; at any hour, 103; table of, 103.
- Azimuths, observed, 100, 104-5; from shadow of tree, 100; theoretical, 105; table of, 105.
- Diurnal path, observed with Circles, 107; without instruments, 106; graphic representation, 111; table for, 107.
- See also Latitude, Time.
- Sun-dial, construction and graduation, 17; graduation from globe, 76; observation for time, 113 Obs. 4; showing effect of refraction, 119.
- Sun-fast and sun-slow, 37; for different places in New England, 43 a.
- Sunrise and sunset, observed and theoretical, 108; change in point of, 106; on lunar mountains, 217.
- Sunset, retardation of, 118; time of, compared with moonrise, 141.
- Sun spots showing period of rotation, 215.
- Table for finding moonrise, 136, Appendixes C and D.
- Tables, altitudes of sun from observation, with checks, 103.
- Altitudes and azimuths for diurnal path of Fomalhaut, 134; of Mars, 134; of moon, 134; of sun, 107.
- Azimuths of sun from observation, with checks, 105.
- Diurnal path of sun at Cleveland, 78.
- Diurnal path of sun at summer solstice, 79.
- Duration of sunset, 118.
- High and low paths of the moon, 82.
- Interval between sunset and moonrise, 141.
- Moonrise in April, 140.
- Moonrise in October, 139.
- Positions of ecliptic, 194.
- Positions of Milky Way, 208.
- Sunrise and sunset, observed and computed, 108.
- Varying length of days, 80.
- Tables of Ephemeris, see Ephemeris.
- Telescope, directions for making a small, 19, Appendix A; tests for, 20.
- Home-made, No. 1, field of view, 20 d; field of view used for determining sun's diameter, 214; focal length, 20 b; images, 20 e; light-gathering power, 20 a; magnifying power, 20 c; used in observation of comet, 222; lunar objects, 216; Jupiter's satellites, 220; Milky Way, 225; Saturn's rings, 219; Venus's crescent phase, 219; Vesta, 221; sun spots, 215.

- Home-made, No. 2, compared with No. 1, 223; compared with Galileo's, 224.
- Terminator, moon's, position of, 217.
- Time, different kinds of, see Apparent, Local, Mean, Sidereal, Standard.
- Equation of, 36, 50.
- From hour-angles, 39.
- From observation at transit of sun, 112; at transit of moon, 146; at transit of star, 198, 201.
- From observed altitude of sun, 113 Obs. 1, 3; of moon, 145; of Mercury, 176; of star, 199.
- From observed azimuth, of sun, 108; of moon, 135.
- From observed altitude and azimuth of sun, 113 Obs. 2; of moon, 137; of Jupiter, 177; of star, 200.
- From β Cassiopeiæ, 197.
- Transit, meridian, observed of moon, 146; of star without instruments, 198; of star with plumb lines, 201 Obs. 1; of star with transit tube, 201 Obs. 2; of sun, 112 Obs. 2.
- Theoretical from almanac, 38, 43 a; of moon from its age, 45.
- Transit tube, description, 18; adjustment and use, 112 Obs. 2, 146, 201 Obs. 2.
- Twilight bow and earth's shadow, 121.
- Twilight, length of, 120.
- Uranus identified, 175.
- Variable stars, 205-7; suggestions for observing, 205; minimum of Algol, 206; maximum of Mira, 207.
- Venus, conjunction with Mercury, 163; crescent phase seen in small telescope, 219; daytime visibility, 162; maximum elongation, 164; elongation near inferior conjunction, 165; motion compared with that of Jupiter, 167; diurnal path, compared with that of a star, 166.
- Vesta, with opera-glass and small telescope, 221.
- Watch error found from sidereal clock, 54; sign for, 69.
- Weighting observations, 4.
- Working-list, 1.
- Zenith point on celestial globe, 70.
- Zodiacal light, 122, Appendix B.



TEXT-BOOKS ON ASTRONOMY

REVISED EDITIONS

By CHARLES A. YOUNG,

*Professor of Astronomy in Princeton University, Princeton, N. J.,
and Author of "The Sun."*

Lessons in Astronomy. Including Uranography. Revised Edition. 12mo. Cloth. Illustrated. 366 pages, and four double-page star maps. For introduction, \$1.20.

Elements of Astronomy. With a Uranography. Revised Edition. 12mo. Half leather. 464 + 42 pages, and four double-page star maps. For introduction, \$1.60.

Uranography. From the *Elements of Astronomy*. Flexible covers. 42 pages, and four double-page star maps. For introduction, 30 cents.

General Astronomy. Revised Edition. A text-book for colleges and scientific schools. 8vo. 630 pages. Half morocco. Illustrated with 250 cuts and diagrams, and supplemented with the necessary tables. For introduction, \$2.75.

A Series of text-books on astronomy for higher schools, academies, and colleges. Prepared by one of the most distinguished astronomers of the world, a most popular lecturer, and a most successful teacher.

The **Lessons in Astronomy** was prepared for schools that desire a brief course free from mathematics. The book has just been revised and brought fully up to date. Great pains has been taken not to sacrifice accuracy and truth to brevity, and no less to bring everything thoroughly up to the present time.

The **Elements of Astronomy** is a text-book for advanced high schools, seminaries, and brief courses in colleges generally. Special attention has been paid to making all statements correct and accurate.

The eminence of Professor Young as an original investigator in astronomy, a lecturer and writer on the subject, and an instructor in college classes, led the publishers to present the **General Astronomy** with the highest confidence; and this confidence has been fully justified by the event. It is conceded to be the best astronomical text-book of its grade. The present edition has just been thoroughly revised and enlarged.

GINN & COMPANY, Publishers,

Boston. New York. Chicago. Atlanta. Dallas.

STAR ATLAS

By WINSLOW UPTON,

*Professor of Astronomy and Director of the Ladd Observatory in
Brown University.*

Folio. Cloth. 29 pages + Star Maps. For Introduction, \$2.00.

This Atlas is intended for those who wish to become acquainted with the constellations or to find the position of the leading double stars, variable stars, clusters, or nebulae readily visible in small telescopes.

It contains large charts of the heavens, with the stars prominently defined and the constellation figures in dim outline, and also auxiliary charts and tables to facilitate the use of the Atlas by teachers and students.

Professor William M. Davis, *Harvard University*: An excellent elementary atlas — one that I should recommend to beginners, young and old, with telescopes or without.

Professor H. M. Perkins, *Ohio Wesleyan University*: It is the neatest and best-executed star atlas I have ever seen; not too full, yet ample for all the requirements of the student.

Professor Edwin B. Frost, *Dartmouth College*: It seems to me to be the best of its kind published in English.

Principal D. W. Hoyt, *High School, Providence, R.I.*: We are now using the Star Atlas in our class.

Professor H. A. Howe, *University of Denver*: The most satisfactory atlas for the use of college students and others of like attainments in astronomical knowledge that I have ever seen.

GINN & COMPANY, Publishers,

Boston. New York. Chicago. Atlanta. Dallas.



179
125 L

THIS BOOK IS DUE ON THE LAST DATE
STAMPED BELOW

AN INITIAL FINE OF 25 CENTS

WILL BE ASSESSED FOR FAILURE TO RETURN
THIS BOOK ON THE DATE DUE. THE PENALTY
WILL INCREASE TO 50 CENTS ON THE FOURTH
DAY AND TO \$1.00 ON THE SEVENTH DAY
OVERDUE.

MAR 24 1943

LD 21-100m-7,'39(402s)

QB62
B9

Byrd

82464

