

XVIII. *Description of a Forty-foot Reflecting Telescope.* By
William Herschel, LL.D. F. R. S.

Read June 11, 1795.

THE uncommon size of my forty-foot reflecting telescope will render a description of it not unacceptable to lovers of astronomy. I shall therefore endeavour to give as complete an idea of its construction as the limited compass of this paper will permit, and hope that, with the assistance of the annexed drawings, the mechanism of it will be sufficiently intelligible to such as have been in the habit of viewing machines and mechanical works.

It will be necessary to mention a few circumstances that led the way to the construction of this large instrument, in the execution of which two very material requisites were necessary: namely, the support of a very considerable expence, and a competent experience and practice in mechanical and optical operations.

When I resided at Bath I had long been acquainted with the theory of optics and mechanics, and wanted only that experience which is so necessary in the practical part of these sciences. This I acquired by degrees at that place, where in my leisure hours, by way of amusement, I made for myself several 2-foot, 5-foot, 7-foot, 10-foot, and 20-foot NEWTONIAN telescopes; besides others of the GREGORIAN form, of 8 inches, 12 inches, 18 inches, 2 feet, 3 feet, 5 feet, and 10 feet focal

length. My way of doing these instruments at that time, when the direct method of giving the figure of any of the conic sections to specula was still unknown to me, was, to have many mirrors of each sort cast, and to finish them all as well as I could; then to select by trial the best of them, which I preserved; the rest were put by to be repolished. In this manner I made not less than 200, 7-feet; 150, 10-feet; and about 80, 20-feet mirrors; not to mention those of the GREGORIAN form, or of the construction of Dr. SMITH'S reflecting microscope, of which I also made a great number.

My mechanical amusements went hand in hand with the optical ones. The number of stands I invented for these telescopes it would not be easy to assign. I contrived and delineated them of different forms, and executed the most promising of the designs. To these labours we owe my 7-feet NEWTONIAN telescope-stand, which was brought to its present convenient construction about 17 years ago; a description and engraving of which I intend to take some future opportunity of presenting to the Royal Society. In the year 1781 I began also to construct a 30-feet aerial reflector; and after having invented and executed a stand for it, I cast the mirror, which was moulded up so as to come out 36 inches in diameter. The composition of my metal being a little too brittle, it cracked in the cooling. I cast it a second time, but here the furnace, which I had built in my house for the purpose, gave way, and the metal ran into the fire.

These accidents put a temporary stop to my design, and as the discovery of the GEORGIAN planet soon after introduced me to the patronage of our most gracious King, the great work I had in view was for a while postponed.

In the year 1783 I finished a very good 20-feet reflector with a large aperture, and mounted it upon the plan of my present telescope. After two years observation with it, the great advantage of such apertures appeared so clearly to me, that I recurred to my former intention of increasing them still farther; and being now sufficiently provided with experience in the work I wished to undertake, the President of our Royal Society, who is always ready to promote useful undertakings, had the goodness to lay my design before the King. His Majesty was graciously pleased to approve of it, and with his usual liberality to support it with his royal bounty.

In consequence of this arrangement I began to construct the 40-feet telescope, which is the subject of this paper, about the latter end of the year 1785. The wood-work of the stand, and machines for giving the required motions to the instrument, were immediately put in hand, and forwarded with all convenient expedition. In the whole of the apparatus none but common workmen were employed, for I made drawings of every part of it, by which it was easy to execute the work, as I constantly inspected and directed every person's labour; though sometimes there were not less than 40 different workmen employed at the same time.

While the stand of the telescope was preparing I also began the construction of the great mirror, of which I inspected the casting, grinding, and polishing; and the work was in this manner carried on with no other interruption than what was occasioned by the removal of all the apparatus and materials from Clay-hall, where I then lived, to my present situation at Slough.

Here soon after my arrival, I began to lay the foundation,

upon which by degrees the whole structure was raised as it now stands; and the speculum being highly polished and put into the tube, I had the first view through it on Feb. 19, 1787. I do not however date the completing of the instrument till much later; for the first speculum, by a mismanagement of the person who cast it, came out thinner on the centre of the back than was intended, and on account of its weakness would not permit a good figure to be given to it. A second mirror was cast Jan. 26, 1788; but it cracked in cooling. Feb. 16, we recast it with particular attention to the shape of the back, and it proved to be of a proper degree of strength. Oct. 24, it was brought to a pretty good figure and polish, and I observed the planet Saturn with it. But not being satisfied, I continued to work upon it till Aug. 27, 1789, when it was tried upon the fixed stars, and I found it to give a pretty sharp image. Large stars were a little affected with scattered light, owing to many remaining scratches in the mirror.

Aug. the 28th, 1789. Having brought the telescope to the parallel of Saturn, I discovered a sixth satellite of that planet; and also saw the spots upon Saturn, better than I had ever seen them before, so that I may date the finishing of the 40-foot telescope from that time.

Description of the Instrument. See Tab. XXIV. to XLII. inclusively.

Fig. 1. represents a view of the telescope in a meridional situation, as it appears when seen from a convenient distance by a person placed towards the south-west of it.

The foundation in the ground consists of two concentric circular brick walls, the outermost of which is 42 feet in dia-

meter, and the inside one 21 feet; these measures are reckoned from the centre of one wall to the centre of the other. They are 2 feet 6 inches deep under ground; two feet 3 inches broad at the bottom, and 1 foot two inches at the top; and are capped with paving stones about 3 inches thick, and $12\frac{3}{4}$ broad. Fig. 2. represents a section of one of them.

These walls were brought to an horizontal plane by means of a beam turning upon a pivot fixed in the centre of the circle, which had a roller under it at the end. Upon this beam and over the roller was fixed a spirit level, to point out any defect in the walls; and by correcting every inequality that could be perceived, they were by degrees brought to be so uniformly horizontal that the beam would roll about every where upon them without occasioning any alteration in the bubble of the spirit level.

The timber of the groundwork (see fig. 3.), in the construction of which it was necessary to join strength to lightness, is put together in the following manner: three principal beams, A A, B B, C C, are extended from south to north, when the telescope is in a meridional situation. They are 43 feet 2 inches long, 6 inches broad, and 6 inches thick. The distances of the centre of the two outside ones is 17 feet. Within one foot of the ends of them are bolted down the cross beams DD, E E; which serve as a foundation to the two sets of ladders. These cross beams are 19 feet 2 inches long, 12 inches broad, and 6 inches thick; and by way of additional strength two more, F F, G G, of the same breadth and thickness, are bolted against the sides of the former, resting also upon the longitudinal beams, but these are rounded off at the ends, as marked in the figure.

The firmness of the foundation in the direction from south to north being thus secured, it became equally necessary to provide for strength in the support from east to west. For this purpose there are three latitudinal cross beams, H H, I I, K K, bolted down upon the former longitudinal ones. That which crosses the centre is 45 feet 2 inches long, and 12 inches broad; its thickness, like that of all the ground timber, being 6 inches. The other two are about 39 feet 9 inches long, and 6 inches broad. They project beyond the circular foundation wall about 8 inches, while the middle one projects 12. The use of these cross beams is to receive six supporters upon their respective ends, at the places which are marked with an ellipsis; the supporting beams which stand upon them being round and inclined towards the ladders, which they are to keep steady in the east and west direction.

Under each end of the principal beams at A A, B B, C C, H H, I I, K K, is placed a roller which rests upon the outer foundation wall. The three latter of these beams being placed higher than the former, have a piece of a proper thickness under the ends to bring the bottom of them to the level with the former. The rollers are set in iron frames, and bolted to the beams, so as to be directed to the centre of their motion. They are 8 inches long, and 6 in diameter. The construction of those which are under beams that come from the centre, is expressed in fig. 4.; but the irons which hold the rollers under beams in other directions are more or less eccentric, as may be seen in fig. 5.

No other fastening in the whole machinery of the wood-work has been admitted but screw bolts; as tenons of any kind, in an apparatus continually to be exposed to the open

air, will bring on a premature decay, by lodging wet. In order to obtain steadiness, however, the cross timbers of the frame, in all places where they are bolted together, are let in, and receive each other about $\frac{3}{4}$ of an inch, which makes an entering of $1\frac{1}{2}$ inch into each other, and produces the required firmness without any material weakening of the timber.

The twelve rollers whose place has been pointed out, would not have been sufficient to support the length of the beams to which they are fastened, the shortest of which, as we have seen, being near 40 feet long. Eight additional rollers, therefore, sustain the ground timber half way towards the centre at L M N O P Q R S. They are, like the former, directed to the pivot upon which this frame moves, and rest upon the inner foundation wall.

In the centre is a large post of oak, framed together with braces under ground, and walled fast with brick-work so as to make it steady. The two central beams B B, I I, cross each other over this post; and a strong iron pin, or pivot, goes through them both into a socket within the centre of the post, so as to permit the whole of the foundation timber to turn freely upon this centre, when a proper force is applied for that purpose.

Although by means of the 20 rollers, and this support in the centre, the bottom frame of the stand to the telescope be firmly supported, it may notwithstanding be easily seen that there was occasion for some additional braces, in order to keep each beam in its proper situation. For this reason 8 pieces, *a a, b b, c c, d d, e e, f f, g g, h h*, of a proper length, 4 inches broad and 6 deep, are applied near the end of the beams against the sides of them; these are held together by irons

that are bent, as in fig. 6. One of them, for instance, is bolted down, at *a* and *b*, fig. 3. upon the braces that hold the beam H in its place; upon which it is also screwed down, and makes a firm joint of the three pieces. A small entrance of *a* and *b* into H takes off the weight from the iron, and keeps the braces in their places, when bolted together.

Two other braces, *ii*, *kk*, are added. Their use is evident in the horizontal motion of the telescope; for that being effected, as will be seen hereafter by means of the strong centre beam I I, the connection of the whole frame with this beam is completed by the pieces *ii*, AA, BB, CC, *kk*.

Before I proceed to explain any other part of the work in this figure, it will be necessary to describe the construction of the ladders and their braces.

Fig. 7. represents the front set of ladders. $\alpha \beta \gamma \delta \epsilon \zeta$ are six tapering halves of three large poles, or rather small masts, cut through the middle. Before the masts were cut they measured between 11 and 12 inches at the bottom; but when they had been sawed through, the pieces were flattened on the front and back, so as to be reduced to 8 inches at the bottom, and $5\frac{1}{2}$ at the top, while the other dimension, or thickness, was left to its full extent. By trimming up and making them pretty equal, however, they became also reduced to about $5\frac{1}{2}$ and 5 inches in that direction.

The length of the ladders is 49 feet 2 inches, and their construction is as follows. The top of each step is 9 inches from that of the one below it; and, beginning 12 inches from the bottom, there are two rounds and one flat placed alternately, as far as 40 rounds, and 19 flats. In the place of the 20th flat is the centre of the meeting of the front and back sets of

the ladders; above this is another flat, with a termination of 16 inches at the top.

The timber of the sides being tapering, a similar diminution of the flats and rounds has been attended to, especially as their size, in proportion to the sides, is far above what is generally used in building ladders. The flats and rounds are all made of solid English split oak.

The lowest rounds are 2 inches thick in the middle, and $1\frac{1}{2}$ where they enter the sides. At the 21st round the thickness is $1\frac{3}{4}$ in the middle, and $1\frac{3}{8}$ at the shoulder. About the 31st round the thickness is $1\frac{1}{2}$ in the middle, and $1\frac{1}{8}$ at the shoulder, and this size is nearly preserved up to the end. Those parts of the rounds which enter the sides of the ladders have all been turned in a lathe, and are about $\frac{1}{8}$ of an inch tapering, in order to fill the holes properly, which were also made a little tapering so as perfectly to answer the size of the rounds.

The lowest flat, for a particular purpose in the erection of the ladders, which will be explained hereafter, is $4\frac{1}{2}$ inches by 2. The next, as far as the 10th, are $3\frac{1}{8}$ by $1\frac{5}{8}$; from the 11th to the 16th they are $2\frac{3}{8}$ by $1\frac{1}{4}$; and from the 17th to the last $2\frac{1}{2}$ by $1\frac{1}{8}$ inches.

The two outside divisions of the ladders serve for mounting into the gallery, and therefore contain rounds as well as flats. The distance of the sides, the flat parts of which, as in common ladders, are put facing each other, is 18 inches, and remains the same up to the end. But the two inside divisions, which have no rounds, are placed with the flat face outwards, and the distance between these faces being 2 feet 8 inches up to the top, the parallelism of these divisions is preserved outside, while that of the mounting ladders is continued within.

The reason of this arrangement is, that the brackets which support the moveable gallery rest upon the inside frames of the ladders. These go upon 24 rollers, as will be seen hereafter, and 12 of them confining the gallery sideways, while the other 12 support it, the parallelism was of course required where it is placed. The mounting ladders are made parallel within, that a moveable chair, intended to be made if required, might be drawn up with a person seated in it, to prevent the fatigue of mounting, or take up in safety any one who chanced to be afraid of ascending an open ladder.

The back set is constructed like the front; and, the ladders being of the same length, the only difference is that no rounds have been put into them. The flats have been preserved on a double account; first, that the connection of all the side timber might be firm and strong; and secondly, that every part of the frame might be accessible. For by means of these flats we have steps of 27 inches, which may be ascended with tolerable ease, when occasion requires.

The method of joining the front and back at the top, is by passing one set of ladders through the other so as to embrace it; the backs, therefore, which go outside, are placed a little farther asunder than the fronts; and the same pins pass through them both, at η κ and θ ι , where a section of the back ladders is shewn, with the pins going through them. The last flat was put into the ladders after they had been erected and secured together.

The method of setting up and bracing the ladders was as follows:

When the eight principal beams of the groundwork A B C D E H I K, fig. 3. had been put together, the eastern front

ladder $\delta \varepsilon \zeta$, fig. 7. with its back $\xi \circ \pi$ (not expressed in the figure) bolted to it, was laid down edgeways, with the ends δ and ξ opposite to the same letters in fig. 3. and the centre θ towards the west. In this situation the ends were properly secured to the foundation beams, that they might not slip. The centre θ was then raised up to about 10 or 12 feet from the ground, and a tackle was fastened on one side to the crossing of the ladders at ι , and on the other, about 2 feet from the ground, to a tree at a convenient distance in the east. By assisting a little at first, in lifting the centre, our tackle soon got hold of the ladders, and drew them up. A rope had been provided to prevent their going farther than the perpendicular; and being secured in that position, the tackle was now fastened to the other ladder at η ; but instead of making use again of our tree, the corresponding tackle was secured on the top of the first ladder at θ ; by which means we easily drew up the second. Both sets of ladders stood now upon the ground, within the frame, and with the front legs, $\alpha \beta \gamma \delta \varepsilon \zeta$, nearly opposite to the same letters on the front beam; while the legs of the back stood opposite the letters $\lambda \mu \nu \xi \circ \pi$ on the back beam.

We now proceeded to put on the middle top cross-beam, which is placed above the two sets of ladders in the angle made by their crossing each other. It is expressed by points in fig. 7. and may be seen in its place, fig. 1. The method of keeping it there, and securing the proper distance of the ladders by this beam, which is of a cylindrical form, is as follows: twelve iron loops, shaped to the ends of the ladders, with arms to them like lamp-irons, and a hole at the end of each arm, are slipped down upon the ends of the ladders, till two and two of

them, as *a b*, fig. 8. meet in the middle of the cross-beam *c*, which is about 8 inches in diameter. Here a screw bolt, coming up through the beam, passes into the holes of the two irons, where all is screwed firmly together. By this means no holes are made to weaken the tapering ends of the ladders, and the centre beam takes firmly hold of every one of them; so that were even the pins η and θ pulled out, the ladders would still remain firmly kept together.

Before, however, the ladders were screwed to the centre cross-beam they were lifted up into their places upon the front and back foundation beams *D D*, *E E*. This was done by a strong lever-beam, about 25 feet long (see fig. 9.), with two moveable iron claws, *a b*, at the end; which took hold in two places, equally distant from the middle division of the lowest flat of the ladders: this flat having been made, as has been noticed before, sufficiently strong for sustaining the whole weight of a set of ladders. Thus they were lifted one by one into their proper places, and supported till they could be shaped with their lower ends to fit upon their respective bearings, and were in the same manner brought to the required parallel situation: this kind of lever affording the means of giving some small motion to the weight it sustains, not only upon the pivot *c*, but also on the support *d e*, which is rounded off at the bottom.

When the ladders had been properly adjusted to their places, we proceeded to support them immediately by two capital side braces. These consist of two whole masts, of nearly the same dimensions with those which were sawed through for making the ladders: the upper end of each was mounted with an iron loop *a*, two claws *b c*, and ring *d*, which were put on with

bolts, *ef*, as expressed in fig. 10. The poles being drawn up, the loops were put upon the centre pins *uz*, fig. 7. and keyed on; while the lower ends of the poles were lifted into their places, on the cross foundation beam *II*, fig. 3. and fitted upon the elliptical marks at the ends of them at 1, 2.

Before the ladders and side braces were fixed down, a line with an hundred weight at the end, immersed in a tub of water, was hung upon the centre at θ ; and being viewed from a considerable distance, was made to range with the flat side $\delta\theta$ of the ladder. The bottom of every end of the bracing poles and ladders being finally adjusted by this plumb-line, they were all screwed down by strap-bolts, as delineated in fig. 11. The top centre cross-beam was now also screwed to the loops on the ends of the ladders, which, as we have mentioned before, see fig. 8. had been already prepared.

The most essential part of the stand being now erected, we proceeded to brace and support it finally. Four small ladders, but without rounds, 22 feet 9 inches long, having been made, were erected to support the large ones half way. They consist of three half-poles each, placed at the same distance from one another as the large ones, and have their faces turned like them. These meet the former at the 10th flat with their upper ends; while the lower parts of them rest upon the middle foundation beam in fig. 3. at 7, 8, 9, 10, 11, 12; 13, 14, 15, 16, 17, 18. They are screwed both at the top and bottom with flat corner-irons as in fig. 12. and their situation may be seen in fig. 1.

In the next place four less poles were now added to support the ladders sideways. They stand upon the beams *HH*, *KK*, at 3, 4, 5, 6; and are fastened against the ladders at the 10th

flat, or half way up. The upper end is secured with an iron, as in fig. 10. through the loop of which passes a strap-bolt that holds it at the same time with the triangular brace, which will be described, to the ladders. The lower end is strap-bolted down upon the beams, as in fig. 11.

The two long side-bracing poles are supported each by two less poles, which meet them at one half and one quarter of their length from the bottom; or at a height opposite to the 5th and 10th flats of the ladders. Those poles which meet the great ones in the middle are placed with their lower ends upon the middle beam at 19 and 20; and the shortest rest at 21 and 22. They add very materially to the steadiness of the frame in the east and west, or lateral direction; at the bottom they are also fastened by strap-bolts as in fig. 11. and at the top by loops, as in fig. 10. They may also be seen in fig. 1.

The next braces we are to describe are those of the sides of the ladders, and these it will be seen by fig. 13. are of so simple a nature, that a bare inspection of their representation will be sufficient. The size of the horizontal pieces is 6 inches by $3\frac{1}{2}$; but those which are parallel to the ladders, and are of no other use than to keep the rest in their places, or as it were brace-bracers, are only $3\frac{1}{2}$ by $2\frac{1}{2}$.

Besides these there are three sets of braces, which serve to confine the poles to their stations. The highest set meets the side brace of fig. 13. at the 15th flat. The next meets the middle brace at the 10th flat, and both these make with the here mentioned side braces a triangle, in the vertex of which is inclosed the large pole that is braced by them. At the 5th flat a third set of braces, which incloses the two small

poles as well as the large one, is carried round with four divisions. In order not to weaken the great pole by many holes, the braces secure it by a double iron strap, *abcd*, fig. 14; and the small supporting poles which rest upon 19, 20, 21, and 22, fig. 2. are at the same time joined by a single screw-bolt, *ef*, which passes through the loop *gbi* at the end of them, and through the straps which hold the braces to the great pole; see fig. 1.

The back of the ladders is bound together by a large cross, *ab, cd*, from the 10th flat to the middle braces, and by two horizontal pieces, *ef, gh*, as represented upon a small scale in fig. 15. The cross is bolted in twelve places to the ladders, and the horizontal pieces in six places each. The size of these braces is 6 inches by 4; but the lowest horizontal beam, which is used for a point of suspension to lift the mirror in and out of the tube, is 6 inches and a half by $5\frac{1}{2}$; and the bolts that hold it to the ladders are also very substantial.

The front of the ladders, it is very evident, would admit of no brace, and is left entirely open for the tube of the telescope to range in. It receives, however, some confinement from the moveable gallery, which is always hung across the front, in the place where observations are to be made.

This gallery is next to be described. It consists of three separate parts: two double side brackets with a small platform upon them, and a middle passage. The whole of it when joined together is properly railed in at the front by wooden palisades; and on the inside by light iron-capped bars. Each of the brackets by which the gallery is supported consists of three frames; a parallelogram for the bottom, with two trian-

gular sides erected on the former, and held together by a narrow platform on the top. Fig. 16. represents the bottom frame. Its length, ag , is 8 feet 10 inches, and breadth, gb , 2 feet 8 inches. It is made of yellow fir deal, $\frac{1}{4}$ inches broad, and 2 inches thick. Six sets of brass rollers, in iron frames, constructed as represented in fig. 17. by means of the two small screw-bolts, ik , are screwed under the frame, fig. 16. at cde fgb ; so that when this frame comes to be placed upon the front of the ladders at $\beta\gamma$, or $\delta\epsilon$, fig. 3. the 6 rollers in the direction m , fig. 17. will sustain the frame, while the other six, in the direction l , by embracing the flat sides of the ladders, which as has been described are turned outwards for this purpose, will prevent the frame from slipping off sideways, when it rolls up and down the ladders.

Two such triangles as delineated in fig. 18. the wood of which is $3\frac{1}{2}$ by $2\frac{1}{2}$ inches, are fastened to the frame, fig. 16; one, with the side np upon cg , the other upon db . These being joined at the top by the platform of boards, screwed down to the supporters qrs , of that which is represented here, and of the corresponding one, which rests on db , complete the bracket.

Upon the platform are fixed palisades commencing at t , 19 inches from q ; which turn the corner at the front s , and are continued so as to meet the middle platform of the gallery. The palisades over trs are strengthened and rendered steady, by a seat which is fastened against them, and supported from the floor by slight iron bars.

The other double bracket, with its platform, palisades, and seat, which runs upon the right side of the front ladders, is in

every respect the same as that on the left, except that the entrance is here upon the right side, instead of being at the left in the former.

The whole gallery together, the floor of which is represented in fig. 19. takes up a space of 13 feet 6 inches broad, by 6 feet $1\frac{1}{2}$ inches in depth; the middle platform, however, is cut away so as to leave sufficient room for the tube to come forward in high altitudes. At ac and bd it is 4 feet 3 inches, but at ef and gb , a space of 4 feet 10 inches long, it is only 2 feet deep. The front, $cfbd$, contains palisades, which meet those of the left bracket $trsc$ at c , and the similar ones of the right at dik . These palisades are 3 feet 2 inches high. The light iron rails on the inside pass along the edge, $laegbm$, and are only 2 feet $3\frac{1}{2}$ inches in height.

The first requisite in this gallery being that it should be drawn up to any required altitude, it became necessary to connect the two double brackets and the middle platform in such a manner as to bear some little derangement in their level, arising from the inequality of the motion of the side brackets. With a view to this end, the method of uniting the parts is as follows. The dotted lines 1, 2, &c. shew the place of the joists which support the floor of the platform. At the ends, 1, 2, 5, 6, 7, 8, of these joists are six iron hooks, shaped as in fig. 20; they are bolted and screwed with the end no under the bottom of the joists, and rise to the level of them with the arms p , leaving the hooks q projecting. These enter into six proper openings made in the side brackets; three in each: they leave a space of about $\frac{3}{4}$ of an inch between the two brackets and the middle platform, which permits a small irregularity in the level of the three parts to take place without injury to either of them.

The hooks sink down into the floor of the sides so as to be level with the surface; and go over the inside of the supporting triangles, fig. 18.; which, for the sake of additional strength, and to prevent their being galled by friction, are lined with an iron plate at the inside, in all their length.

The light iron rail joining the bars of the inside, which are along the margin *laegba*, fig. 19. are left moveable at the bottom, in the places *la* and *mb*; where they run down into loops; by which means they admit of being a little displaced.

The contrivance to make the junction of the front and side palisades moveable is by means of a front bar. This being slipped upon pins at the end of the rails belonging to the sides, a hole at each end of the bar, lined with an iron plate about 2 inches long, through which the pins pass, permits the bar to be drawn either way. There are moreover at the ends of the rails, which are fixed to the platform, two iron hooks; which, though they bind the rails to the front bar, still permit it to go up or down a little way, as occasion may require. By this means a deviation from the level, amounting to six or eight inches, will occasion no injury to the wood-work. The greatest security against such a derangement of the platform, however, will be explained hereafter, when we come to the mechanism by which it is moved.

There is a small staircase by which we may ascend into the gallery, without being obliged to go up any ladder; and as that is strong enough to hold a company of several persons, and can afterwards be drawn up to any altitude, observations may be made with great conveniency: the activity of an astronomer, however, will seldom require this indulgence. The readiness with which I ascend the ladders, has even prevented

my executing the projected running chair, which may easily be added, to take a single person into the gallery after it has been already drawn up to its destined situation. A view of the staircase in fig. 1. will suffice to point out its construction. I ought only to observe, that in the engraving the gallery is placed higher than where it will join the staircase properly, but that when it is lowered on purpose, it becomes then to be just one step above the little landing-place of the staircase, and the palisades of the former unite with the railing of the latter.

The next piece to be described, is the tube of the telescope. This, though very simple in its form, which is cylindrical, was attended with great difficulties in its construction. No one will wonder at this who considers the size of the tube, and the materials of which it is made.

Its length is 39 feet 4 inches; it measures 4 feet 10 inches in diameter, and every part of it is of iron. Upon a moderate computation, the weight of a wooden tube must have exceeded an iron one at least 3000 pounds; and its durability would have been far inferior to this of iron.

The body of the tube is made of rolled, or sheet iron, which has been joined together without rivets; by a kind of seaming, well known to those who make iron funnels for stoves. It is represented by fig. 21. where the two sheets of iron are left a little open at *ab* to shew the construction, but which being properly compressed will become very nearly flat: the whole outside was thus put together in all its length and breadth, so as to make one sheet of near 40 feet long, and 15 feet 4 inches broad. The tools, forms, and machines, we were obliged to make for the construction of the tube were very numerous. For instance, in the formation of this large sheet, a kind of

table was built for its support, which grew in size as the sheet advanced, till when finished, it was as large as the whole of it. In the formation of the sheet, cramping irons, seaming bars, setting tools, and claw-screws, such as are represented in the figures 22, 23, 24, 25, and 26, were made in great number, to confine and stretch the parts as they were seamed together. The small single sheets of which this large one is composed, are 3 feet 10 inches long, and about $23\frac{1}{2}$ inches broad. Their thickness is less than the 36th part of an inch; or, what will be a more precise measure, a square foot of it weighs about fourteen ounces. They are joined so, that the middle of a whole one always butts against the seam of the preceding two, in the manner of brick-work, where joints are crossed by bricks above and below.

When the whole sheet was formed, which was done in a convenient barn not far from my house, the sides were cut perfectly parallel, and afterwards bent over at the ends in contrary directions, as in fig. 21. to be ready to receive each other. A number of broad hooks, such as were proper for grasping the sides of the sheet, with loops at the other end for cords to go through, see fig. 22. were now prepared with their necessary tackle.

Twelve pulleys were fastened about 11 feet high, on moveable beams, that might be drawn together; six on each side. The sheet was now taken up, by occasioning all the corded hooks to be drawn at the same time, and while it was kept suspended our large table was taken to pieces. Another kind of support was now put under the middle of the sheet to receive it. The form of this was that of an hollow segment, or quarter of a cylinder, cut lengthways, to the extent of a few

feet more than the length of the intended tube; and the concavity of which was formed by the same radius as that of the tube.

The sheet being let down, it rested upon the hollow gutter; for so we may call the machine that was placed under it. Six moveable segments of a whole cylinder, or circular arches, about 3 feet wide each, which had been prepared, were now brought upon the sheet and placed at proper distances from each other. By these the sheet was pressed down upon the foundation, so that no injury could be done by walking upon it. The beams which held the pulleys were now brought close together; which being done, we hung the pulleys of one upon the hooks of the other beam, so as by that means to cross the cords which held the sheet. In this operation we slackened only one of the cords at a time, the rest being sufficient to keep the whole up.

The beams were now again separated, and the cramping hooks by the crossing of the cords drew the two sides of the sheet together.

Here I must take notice, that the circular inside supports, which resembled the machines upon which arches of brickwork are built, were cut in two in the middle, as in fig. 27.; some part of the circumference being taken out, that when they were laid down upon each other they might not fill the tube. Four long wedges, $abcd$, in opposite directions, were confined two and two in the notches ef , gb ; and similar ones at the back. By driving them in very equally, the upper half of the arches might be forced up so as to swell to the full extent of the tube.

When all this was properly arranged, and the arches lowered,

the two sides of the sheet were gradually brought to take hold of each other. As we proceeded, the wedges within the arches were forced in successively, till at last, with much care and considerable difficulty, the two sides completely embraced one another, and were kept stretched by the swelled inside arches.

Another circular arch, closed in with boards all around, well rounded off, and only about 2 feet 3 inches long, had a vacancy at the top into which we could introduce the iron seaming bars, fig. 23. for indenting, and 24. for closing up the long seam of the two sides. This arch also had its stretchers for swelling it up, and served at the same time, as soon as the seam was properly closed, to beat with mallets the whole sheet all around upon its well-finished outside, in order to take away any accidental bulge which it might have received in the long preparations it had undergone, till it came to the present state.

The same arch, as soon as any portion of the tube had been done, was removed to another place, and the whole was by this means completely seamed up.

The theory upon which the strength of so thin a cylinder of iron is founded, is, that the sides of it must unavoidably support it, provided you can secure the cylindrical form of the tube.

It appeared to me the most practical way to obtain this end by the following contrivance. By a few experiments I found that a slip of sheet iron, a little thicker than that of the tube, and doubled to an angle of about 40 degrees, as in fig. 28. might afterwards be made circular, as in fig. 29. The deepest we could conveniently bend, and such as I supposed would answer the end, was when the sides *a b* were about $2\frac{1}{2}$ inches

broad. They were shaped red hot upon a concave tool, which had the required curvature and angle of the slips. The pieces were long enough to form a complete quadrant of the circle, with the ends sufficiently projecting to be seamed together.

Before they were joined the sides received another bending, as in fig. 30. which was given them by tools of a proper convexity. A back was next prepared, consisting of a slip of iron turned up at both sides, and also bent to the circle, as in fig. 31. Last of all, the four quadrants having been put together, and a back put round them, the whole was firmly seamed together, so as to resemble a hollow triangular bar made into a hoop or ring, of a proper diameter to go closely into the tube, so as to keep it extended, and braced to the cylindrical form. A section of the ring with the bottom seam not quite pressed down, in order to shew it better, is represented in fig. 32.

One of these rings was put into the middle of every one of the small sheets, which brought them to about 23 inches from each other. They were carried in edgeways, and afterwards turned about and forced into their respective places. In order to get them in, as they were all obliged to go in from one side, there was substituted, in the room of the circular arches, a kind of temporary props, like fig. 33. that could be easily removed, one at a time, and were narrow enough at *ab* to pass through the hoops while they advanced; and as soon as a ring was in its proper place, no further support became necessary.

In this manner we secured the cylindrical form of the tube; and as soon as this was accomplished, we had every thing removed from within and without, and began to give the tube three or four good coats of paint, inside as well as outside; in

order to secure it against the damp air, to which it was soon to be exposed.

As the tube was now much lighter than it would be hereafter, we transported it into my garden in the following manner. Many short poles, about 5 feet long each, were joined two and two by a piece of coarse cloth, such as is used for sacks, about 7 feet long each. This, being fastened in the middle, left at each end part of the pole to serve as a handle for a person to hold by. The cloth of one of these being put under the tube, there was left one of the poles at each side, and four men taking hold of the ends of the poles, might conveniently assist in carrying the tube. When six sets of these were put under the tube, it was with great facility lifted up by 24 men, who carried it through an opening which we had made at one end of the barn. The inclosure of part of my garden having also been taken down, with some trees that were in our way, it was safely landed upon my grass-plot; where a proper apparatus of circular blocks was put under to receive it. While it remained in this state, we prepared every thing for its reception, and afterwards moved it into its place, and supported it in an horizontal situation.

It will be necessary now to return to the rest of the machinery, which by this time was in great forwardness.

Two solid cast-iron concave rollers, $6\frac{1}{4}$ inches broad, and 10 inches in diameter, are mounted upon an axle or iron bar, $2\frac{1}{2}$ inches square; the axle in the middle being swelled out so as to admit of a pivot $2\frac{1}{4}$ inches thick to pass through it, without being weakened by the hole. The tube is mounted upon this at the lower end, and as the speculum lies in this

part, great strength is requisite to support it firmly, as also an extensive connection of this strong part with the length of the tube. The speculum likewise is to be put in here, and when the telescope is in use the cover of the speculum is to be taken off, and afterwards to be put on again; for which reason a convenient door or opening must be had. The line of collimation of the mirror also requires an adjustment at this end of the tube; and a small side motion is required upon the pivot of the axle, which must not only be perfectly smooth, but equally firm and steady. All these exigencies have been provided for in the following manner.

Fig. 34. represents the back of the tube, closed up by six iron bars, *a b c d e f*, which cross each other. The middle bar is $\frac{1}{4}$ inches broad, and $1\frac{1}{8}$ thick at *e*, but is swelled so as to measure 5 broad, and $1\frac{1}{2}$ thick at *l*, where it is turned at rectangles, and passes under the bottom of the tube. In this bar is a square hole, through which a pivot, or pin, passes from the inside of the tube, where it is confined by a square head, into the hole of the axle, A B, under which at the bottom it is keyed fast at C; with proper washers between the joints to allow of a very smooth motion.

The bar, *c g*, is of the same strength with *e l*, and passes over it at *e*. It is bent at rectangles at *c* and *g*, so as to pass along the sides of the tube. The two bars, *d m*, *f k*, fastened upon *c g*, and afterwards turned down to the back, are 2 inches broad, and $\frac{5}{8}$ thick; and are also bent at rectangles at *m* and *k*, so as to go under the tube: the remaining two bars, *b h*, *a i*, cross the other three bars, with proper offsets; and are bent at rectangles on both sides, that they may turn round the end of the tube, to go along the sides of it. At the crossing

of these bars they are fastened by screws, which pass through the upper bar, and are lodged in the lower one. The same screws pass on through a moderate plate of sheet iron which closes the back, and is held by nuts upon them within the tube. The eight returning bars, at *abcgbik*, extend only to about 6 inches along the tube; but they are immediately received by other eight bars of the same size, which are screwed upon them. These bars are made tapering, so as only to measure $1\frac{1}{2}$ inch broad, and $\frac{3}{8}$ thick at the ends; and they are 9 feet 8 inches long. The middle bar is turned over about 16 inches, and made tapering; and the bar which meets it is laid under it, and also made tapering to answer the former. The pivot goes through both, and they form, as it were, only one bar; this is soon reduced gradually, and at the end measures $1\frac{3}{4}$ inches by $\frac{1}{2}$; its length being the same as the rest.

The segment *cng* is cut off to leave an opening, which is 2 feet broad at the sides. A cover of the same shape, with the piece cut out of the tube, is laid upon the place, to overlap the opening properly. But this would not have been sufficient: for, after observations at night, this cover, though close enough to preserve the inside of the tube from damp or wet, would itself be covered with dew or condensed vapour. And by taking it off in order to secure the mirror, many drops of water would unavoidably fall upon it from this wet cover. To prevent this, an outward cover has been applied, which completely preserves the inner one from moisture.

The tube being much too weak, in this place, for the support of the mirror, a piece consisting of three sheets of iron, 2 feet 4 inches broad, $\frac{1}{8}$ thick, and dove-tailed together so as to be long enough to reach from *c* around *bamlekb* to *g*,

was added to its thickness within ; upon this again, an iron bar, 6 inches broad, and $\frac{5}{8}$ thick, was bent round close to the end, from *b* to *b* only ; and another bar, $2\frac{1}{8}$ inches broad, and $\frac{1}{2}$ thick, made into a complete circle, was added to support that end of the tube which had been cut, to make the entrance. All these pieces were well secured, by screw-bolts passing through the nine long outside bars *abcghiklm*, next through the tube, then through the strong sheet, and at last through the broad strap and circular bars, upon which they were screwed down with nuts at the inside. The more advanced parts of the long bars were secured also by screw-bolts passing through the tube, and through circular straps of hoop iron, about $2\frac{3}{4}$ inches broad, and $\frac{1}{8}$ thick ; one of these being put into every sheet of the tube as far as the bars went.

As we had now secured what I call *the point of support*, it was no less necessary to form a strong *point of suspension*. This was obtained by grasping the tube with a system of bars similar to that which has been employed at the bottom.

Ten bars, equally divided around the circumference, about 10 feet 4 inches long, are placed longitudinally so as to have one of them at the top, and an opposite one at the bottom. Every one of these has six screw-bolts, which pass through the bar and the tube, and also through complete circles of hoop iron, which is of the same breadth and thickness as has been mentioned before. The bars also, except the highest and lowest, are of the size of those which have been used about the point of support. They are also, like them, chamfered at the sides, and begin to lessen in breadth and thickness about 4 feet from the front, to the same dimensions with the former.

The lowest bar is a little stouter in its dimensions, but otherwise exactly the same.

The middle bar at the top is strongest about the point of suspension, where it is $\frac{1}{4}$ inches broad, and 1 inch thick. In this place it is crossed by another bar, which is a segment of a circle, and embraces the middle one, and two other bars at each side. This crossing bar is $3\frac{1}{2}$ inches broad, and 1 inch thick in the centre; chamfered or sloped at the sides, and reduced in thickness towards the ends. It passes over the middle bar with a proper offset, and its two ends terminate upon the two farthest bars; but the bars next to the middle, on each side, are made to pass over it. The middle bar receives a loop, by which the telescope is suspended, the centre of which is 3 feet 8 inches from the mouth of the tube. The loop is made of iron, $\frac{1}{4}$ inches broad, and 1 inch thick; doubled together, and the ends of it opened again, so as to cross the circular bar, and to rest upon the strong middle one, to which it is fastened with four large screw-bolts. These pass through the bar into the tube, where they are well secured with substantial nuts. The long middle bar is reduced gradually after the place of the loop, the ends of which extend about 18 inches, till it comes at last to the breadth of $2\frac{1}{4}$ inches, and thickness $\frac{3}{8}$.

All the ten bars are secured with six screw-bolts each, which pass through the tube, and through iron hoops, four of which are of the same dimensions with those which are used about the point of support. The hoop which is under the suspension is 8 inches broad, and a little thicker than the rest. The front hoop is of a different construction: its thickness is

about two-tenths of an inch, and being bent at rectangles, that part which is held down to the tube, and to the ten bars, keeps it steady, while that in the other direction serves as a ring, both to strengthen and confine the aperture. It projects about three inches all around, and leaves an opening of 4 feet 4 inches to the mouth of the telescope.

The loop of suspension stands across the tube, and receives a round bar of iron, shaped as in fig. 35. which is left at liberty to take its own position. To the places *ab* are hung two double pulleys, and at *c*, a single one; all turning upwards to meet the upper set of pulleys.

On the top of the stand, and round the centre beam, passes a ring of iron, 4 inches broad, and 1 inch thick, which contains a loop resembling that on the point of suspension at the telescope. This also receives a round iron bar, bent as in fig. 36. and supports three double pulleys at *def*.

Nothing can obstruct the motion of a tackle more than the friction of the ropes against each other; and as the utmost ease was required in the action of my pulleys, it was particularly necessary to guard against a defect of that kind. Another inconvenience was to be avoided, still more pernicious than the friction of the tackle. When pulleys are set, two, three, or four in a row, side by side, they will incline one way when the weight is drawn up, and another when it is let down. This may easily occasion an accident, which in the case of my large telescope must have been exceedingly troublesome, and probably in the end proved fatal; for by the side inclination of the set, a rope will sometimes slip out of its place; especially as my ropes are well soaked in melted tallow to preserve them from moisture. This in summer will occasion dust to

settle upon them, and sometimes fill up a channel of the pulleys, so that the least deviation from the perpendicular may throw a rope out of its place. Should this happen in the night, when it might not be immediately perceived, the rope would soon be injured, or even cut through, by the continuation of the force that acts upon it. Besides, this irregular motion of the pulleys, when the telescope is finely suspended in the meridian, will tend to produce a little deviation in right ascension, which ought to be avoided. My pulleys, therefore, are all but one in a meridional situation, and this might also be turned the same way if there were occasion for it. The double pulleys are placed under each other; by which means the stress of the lower ones at the top, and the upper ones at the bottom, adds to their meridional and perpendicular steadiness.

In order to command every altitude, from the horizon to the zenith, it was necessary that the point of support should be moveable. Its motion is effected by a mechanism which I shall now explain.

Eight bars, $2\frac{1}{2}$ inches broad, and $1\frac{1}{8}$ thick, were cut into teeth at the distance of $1\frac{1}{2}$ inch each; and afterwards connected by slips screwed against both sides of the places where two butt together. Their length is such, that four and four being joined make up two bars of 29 feet 8 inches long each. Two loops which are screw-bolted to the ends of them, take hold of the axle, fig. 34. at D and E, which in those places is made round for that purpose.

Upon the foundation beams in fig. 3. are fixed four short cross beams, at *ll mm nn oo*; these carry the following machine. A handle which turns a pinion of eight leaves, drives a wheel of 20 inches diameter, with 51 teeth; the axle of the wheel

contains a pinion of 12 leaves, driving a wheel 3 feet in diameter, of 88 teeth. On the axle of this latter are fixed, upon a long bar, two lantern pinions of twelve leaves, at a distance of 3 feet 9 inches from each other, and these are confined down to work in the two long cut bars, which pass under them at that distance in iron notches, to prevent their receding sideways. The long bars are supported by narrow slips of timber, *pp*, *qq*, which are extended from the front to the back; as otherwise the weight of these bars would bend them down so as to render them unfit for action. The slips are covered with sheet iron, that they may not be injured by friction. The front ends of the bars are furnished with claws, which keep them in their places upon the slips.

Two supporters of oak, 29 feet 8 inches long each, 6 inches broad, and 4 thick, are extended from *rs* near the pinions, to *rs* at the back. These are made convex at the top so as to fit the concavity of the iron rollers *AB*, fig. 34. They are also covered with pretty thick sheet iron, to prevent their being worn by the motion of the weight which is to go upon them. The distance from the centre of one to that of the other is 5 feet $4\frac{1}{2}$ inches.

These things being arranged as has been described, it appears clearly that, when the handle of the first pinion is turned, the system of wheels and pinions in the machine will draw the bars, and consequently the point of support of the tube, forward into any required situation; and return it back to its former place, by turning the same handle a different way.

At *S'*, fig. 3. near the platform of boards, *tt vv*, is placed a barrel, 19 inches in diameter, and 17 broad, with high sides to confine the long rope which draws up the point of suspension

of the telescope by means of the pulleys that have been described. On one side of the barrel is a wheel, 2 feet 3 inches in diameter, with 91 teeth; and a handle with a pinion of 4 leaves gives motion to it, when the telescope is to be lifted up or let down.

The method of stringing the pulleys is expressed in fig. 37. The rope A, coming from the great barrel, passes successively over the pulleys 1, 2, 3, 4, 5, 6, 7, 8, 9, 10, 11; and from B goes to another barrel, T', fig. 3. which is also near the platform *t t v v*, the use of which will be explained hereafter.

By the assistance of these two motions, the telescope may be set to any altitude, up to the very zenith; and in order to have the direction of it at command, a foot quadrant of Mr. BIRD'S is fixed at the west side of the tube, near the end of it, inclosed in an iron case; upon the top of which is also planted a finder, or night-glass, about 21 inches long, with cross wires in the focus. The divisions of the quadrant are indicated by a spirit-level, instead of a plumb-line.

The axle, which turns the first pinion of the mechanism for moving the point of support, carries a pallet. This gives motion to a small wheel with studs, contained in a machine fixed to the frame of the great wheel-work, and inclosed in a little box. The wheel with the studs carries a perpetual screw, which moves a central wheel, upon the axis of which is fixed an index-hand, that passes over a graduated plate of 140 divisions. Each of these divisions answers to four turns of the handle; and they are large enough that a 4th part of one of them may be distinguished. In this manner the hand will point out how many turns of the handle have been made to move the telescope from its most backward point of support to the most forward.

I call this machine the *bar-index*. It is of eminent use in giving us immediately, by means of a table made for that purpose, the place of the point of support for any given altitude or zenith distance of the quadrant.

In order to come at every part of the heavens, the vertical motion of the telescope requires the addition of the horizontal one. This has been obtained by another very simple mechanism. We have already seen that the bottom frame rests upon 20 concentric rollers, and is moveable upon a pivot.

At *ww xx y*, fig. 3. is a machine in every respect like that which has been described as giving motion to the point of support, except that instead of a bar with two lantern pinions, the great wheel here carries an iron barrel, 2 feet 8 inches long, and 5 inches in diameter. Near the ends of the great cross beam II, are planted two pulleys; one at T, the other at V. Round the outer circular wall is a gravel-walk, 12 feet broad; and on a grass-plot close to the margin of this walk are eight posts of oak, in large frames, firmly buried in the ground, at equal distances, so as only to shew their heads sufficiently to admit an iron ring and pulley to be hung upon them as occasion may require; the middle beam also carries an iron loop at each end.

A strong rope is now thrown round one of the spokes of the wheel, next to the barrel, which passes with one of its ends under the bottom of it, while the other remains at the top. As soon as the handle puts the wheel-work in motion, the barrel will draw both ends of the rope, but in contrary directions. One of the ends is then to be led to the pulley on the great beam at T, while the other is made to pass over that at V; but in a contrary direction. Upon the nearest post at rectangles

to the great beam, towards the south, for instance, is hung a ring with a pulley to it; while, at the same time, a similar ring and pulley is fastened to another post, near the opposite end of the beam, but situated towards the north. The ends of the rope are now returned through these pulleys, and with iron hooks, which are fastened to them, are hung in the loops at their respective ends of the middle beam.

As soon as the ropes are sufficiently and equally stretched, the telescope will begin its horizontal motion, which may be continued as long as the same posts will be conveniently situated. In order to go on with the motion, the ropes are to be slackened, and the rings being then hung upon the two next posts, we may continue at pleasure to turn the telescope to any part of the heavens that may be required. The arrangement is represented upon a small scale in fig. 38.

It should be noticed, that the ends of the rope must be equally stretched, for which reason a mark ought to be made in the place, which is to be thrown round the spoke of the wheel. The fastenings of the pulleys also, which are joined to the rings that are thrown over the posts, ought to have an adjustment by links and hooks, to be either lengthened or shortened at pleasure.

With the assistance of the motions that have now been described, I have in the year 1789, many times taken up Saturn, 2 or 3 hours before its meridian passage, and kept it in view with the greatest facility, till 2 or 3 hours after the passage; a single person being able, very conveniently, to continue both the horizontal and vertical motions, at the command of the observer. In this however ought to be included an assisting third motion, which I am in the next place to explain.

We have seen that in fixing the ladders they were set at 8 feet 2 inches distance in front, in order to permit the telescope to have a side motion, without displacing the whole apparatus, which is designed for a meridional situation.

Every celestial object, when it passes the meridian, is then in its most favourable situation for being viewed, on account of the greater purity of the atmosphere in high altitudes. The advantage also of being able to direct the instrument, by means of the quadrant, to the spot in which we are to view the object, is considerable, in so large an instrument as the 40-foot telescope. With unknown objects, it is likewise of the greatest consequence to be enabled, by a meridional situation, to ascertain their place. But, as a single passage through the field of view, especially with my examinations of the heavens in zones, would not have been sufficient to satisfy the curiosity of an observer, when a new object presented itself, it became necessary to contrive a method to lengthen this interval. The tube, therefore, as we have seen, is made to rest with the point of support in a pivot, which permits it to be turned sideways.

Its diameter being 4 feet 10 inches, and that part which is generally opposite the ladders that confine it in front being about 35 feet from the pivot, it appears that a motion of 3 feet $\frac{1}{4}$ inches may be had, which to the radius of 35 feet gives upwards of five degrees of a great circle.

Several abatements must be made on account of the disposition of the apparatus that gives this side motion, and the shortness of the ropes in high altitudes; but there remains, notwithstanding, a sufficient quantity of this lateral motion to

answer the purpose of viewing, pretty minutely, every object that passes the meridian.

Before I can give the particulars of this side motion, some other things must be explained. The point of support rests in a pivot; but this alone could not have given steadiness to a tube of 4 feet 10 inches in diameter, loaded with the weight of the strengthening bars, and speculum, which rest upon it. Two moveable supporters have therefore been provided at *p q*, fig. 34. They consist of two solid brass rollers, 3 inches thick, and $4\frac{1}{2}$ in diameter; set in strong frames firmly united to the sides of the tube, and resting upon the flat face of the square axle AB, which carries the pivot in the centre. The middle of these rollers is applied about 2 feet 2 inches from the centre of the pivot; and being set so as to lose none of the motion which they may have upon the axle, we find that there is room for full as much angular motion of the rollers upon the axle, as there is for the tube between the sides of the ladders; and indeed more than can be wanted, as 10 minutes of time are generally sufficient for viewing any object.

The method of observing with this telescope is by what I have called the front view; and the size of the instrument being such as would permit its being loaded with a seat, there is a very convenient one fixed to the end of it. The foot-board or floor, is 3 feet broad, and 2 feet $2\frac{1}{2}$ inches deep. The seat is moveable from the height of 1 foot 7 inches to 2 feet 7 inches, not so much for the accommodation of different observers, as for the alteration which is required at different altitudes, and which amounts to nearly 12 inches. One half of the seat falls down, to open an entrance at the back; and being

inclosed at the front and sides, a bar which shuts up the back after the observer is in his place, secures the whole in such a manner as to render it perfectly safe and convenient.

There are two strong iron quadrants with teeth, at the sides of the seat, in which run two pinions fixed upon a bar, with a ratchet and handle at the end of it. By turning that handle, the seat is easily brought to an horizontal position, before the observer enters it; or restored to it, when any considerable alteration in the altitude of the telescope renders a change necessary.

The focus of the object mirror, by its proper adjustment, is brought down to about 4 inches from the lower side of the mouth of the tube, and comes forward into the air. By this arrangement, there is room given for that part of the head, which is above the eye, not to interfere much with the rays that go from the object to the mirror; the aperture of the speculum being 4 feet, while the diameter of the tube is 4 feet 10 inches; especially as we suppose a night observer will prefer some kind of warm cap to a hat, the rim of which might obstruct a few of the entering rays.

A long coarse screw-bar is confined in a collet, which takes on and off, and may readily be put to the inclosing right side of the seat, so as to present the observer with a short handle. The other end of this bar passes into a nut, which, like the collet, moves upon a double swivel, so as to admit of every motion. The nut is planted upon a machine which will be described hereafter, and may be drawn up to any altitude, so as to bring the nut upon a level with the swivel of the handle. Upon turning the handle, the observer will screw himself, the seat, and the telescope, from the ladder; and may thus follow

the object he wishes to pursue in its course, for as many minutes as may be convenient. If, indeed, he is inclined to give up the meridian for some time, he may order the whole frame to be moved by the great round motion, which ought to be in readiness; and may even keep his object in view, as I have often done, by screwing the telescope backwards as fast as the round motion advances it. Then screwing himself forward again, he may repeat these successive motions as long as he pleases.

In those observations, which I have called sweeps (from the method of oscillating or sweeping over an arch, which at first I had adopted in the way of right ascension, but which in the year 1783 I reduced to a systematical method of sweeping over zones of polar distance), several conveniences are required: the principal of them are as follows.

An assistant, provided with an apparatus for writing down observations; with catalogues of stars, atlases, and other resources of that kind.

A small apartment, as near to the observer as possible, in which this apparatus, with candles and other conveniences, may be inclosed.

A sidereal time-piece.

A right ascension apparatus.

A polar distance apparatus.

A polar distance clock.

A zoned catalogue of the stars.

And a ready communication between the observer and assistant, both ways.

There is also wanting, a person to give the required motions for sweeping the zones of the heavens.

A micrometer-motion to perform the sweeps.

A zone-piece, to point out the required limits of the intended zones.

A small apartment to inclose these motions, and the candle which is required for the workman.

And a ready communication, for the observer to direct the workman in the required motions.

All these conveniences were gradually brought to perfection with my 20-foot telescope; but here, they were at once, and with great advantage, designed and executed in their most improved state.

A' B' C' D', fig. 3. is the floor of the observatory, 8 feet 5 inches by 5 feet 5. It is of a proper height, and has a double window towards the west, with a shutter to be used at night. Fig. 1. gives a sufficient view of it.

E' F' G' H', is the floor of the working room, which is 6 feet 6 by 4 feet 5; and has two small windows, one to the south, the other to the east. Its height is considerably less than that of the observatory; and a view of this may also be seen in fig. 1.

The distance between the observatory and the end of the telescope, is evidently too far for a conversation in the open air, between the observer and assistant; especially as the latter, on account of his candles, must be inclosed; and ought not to leave his post at the time-piece and writing-desk. Add to this, that when the observer is elevated 30 or 40 feet above the assistant, a moderate breeze will carry away the sound of his voice very forcibly. A speaking-pipe was therefore necessary, to convey the communications of the observer to their destination.

At the opening of the telescope, near the place of the eyeglass, is the end of a tin pipe, into which at the time of observation a mouth-piece may be put, which can be adapted, by drawing out, or turning sideways, so as conveniently to come to the mouth of the observer, while his eye is at the glass. This pipe is $1\frac{1}{2}$ inch in diameter, and runs down to the bottom of the telescope, to which it is held by proper hooks, that go into the tube, and are screwed fast at the inside. When it is arrived as near to the axle AB, fig. 34. as convenient, it goes into a turning joint; thence into a drawing tube, and out of this into another turning joint; from which it proceeds by a set of sliding tubes towards the front of the foundation timber.

The mechanism of the first turning joint and short sliding tube, as well as the next turning joint, is executed in brass, as represented in fig. 39. The tube *a* is the continuation of the pipe which comes down from the observer; at *b* and *c* it is turned about in an angle, but the part *b* and *c* consists of a double brass tube, one of which may be turned within the other. *bde*, is an arm which has two pivots, one at *b*, the other at *c*; the part *d* is put through, and pinned to a fastening at the tube, where it is also permitted to turn about if required. When the telescope is lifted up, the pipe *abc* turns upon the pivot *b*, and within the pipe *bce*; which also turns upon the pivot *c*; so that *abc* may come at rectangles to *bce*, when the telescope is turned up to the zenith. At the same time *ce* sliding in *fg*, will be drawn out, since *bc* is not in the axis of the vertical motion, which lies in AB, fig. 34. but turns in a small arch about it. The point *c* will not only be drawn back, but will also be lifted up, and therefore a second turning joint, *bg*, becomes necessary, which is of the

same nature with the first. From *bi* the pipes are continued in three joints of 9 feet 6 inches long each. These slide into one another as far as is required, and, all together, into a fourth pipe, when the telescope is advanced to the place where it rests in zenith observations. The fourth pipe, which is the largest, goes to the end of the frame *H'*, fig. 3. where it turns towards *I'*; and is there again made to return to *K'*. At this last place it divides itself into two branches, one going into the observatory, to *L'*, where it rises up through the floor; the other going into the work-room to *M'*, where it also ascends through the floor, up to the level of the workman's ear, who stands just by the place where it terminates in the usual shape of speaking pipes. Notwithstanding the passage of the sound through a pipe with many inflections, and not less than 115 feet in length, I find that it requires no particular exertion to be very well understood; and that the communication is quite sufficient for the purpose; though undoubtedly some advantage might have been gained if brass sliding tubes had been used throughout the whole length. Under the long pipes that slide into one another, is a semicircular gutter, extended from *N'* to *O'*, which keeps the pipes in their place, as they are carried along by the motion of the telescope, when the point of support is advanced or drawn back; and the large gathering pipe is inclosed in a box, *N'H'*, to secure it from accidents.

The right ascension apparatus is constructed thus. Against the sides of the tube, and 2 feet 6 inches from the mouth of it, are fixed the centres of two rubbing plates, 3 feet 10 inches long, 2 feet 1 inch broad, and near 2 tenths of an inch thick. These plates are fastened to the long bars of the tube, nearest

the top and bottom, by six arms each ; and screwed on so as to be perpendicular to the horizon. The plate on the west is fixed, but that on the east is adjustable, in order to be kept perfectly vertical on every part of its surface. One of these is visible against the tube, in fig. 1. An iron roller, 1 inch thick, and $2\frac{1}{2}$ in diameter, is set in a strong frame, in such a manner as to allow the claw, which holds it, to be set to any direction ; where it can be afterwards fastened by a large horned nut. This roller is mounted upon a frame, see fig. 40. that may be drawn up to any altitude, and lies upon the whole set of ladders on the east ; where it rolls up and down on six sets of brass rollers, *abcdef*, which are constructed as in fig. 17. This machine consists of a bottom frame, and a bar, *gb*, at rectangles to it, which, when the frame lies upon its rollers on the ladders, stands also at rectangles to them, on the lowest part of the frame : it is braced so as to make the greatest resistance from east to west. The bar carries the iron roller, which may be shifted to two different situations ; *g* almost down to the ladders, and *b* more elevated. The latter is used in high altitudes. The iron roller, standing out, is then turned so about as to be in the direction of the length of the eastern rubbing iron ; in which situation it is fixed by the horned nut. The telescope is then brought forward, or backward, by the bar machine, till the rubbing iron comes to be opposite the roller.

Upon one of the braces of this same frame at *i*, is also planted the nut belonging to the lateral screw motion, which has been described ; and its long bar goes always with this machine, when it is disengaged from the observing chair, and is laid back at *k* into a secure resting place.

On the opposite set of ladders is another machine, which

carries a large spring-bolt, on the end of which is mounted an iron roller, exactly like that which has been described. This is also adjustable to any direction. The bolt is contrived in such a manner as to come out of the frame, in which it runs, with a pressure of 34 pounds; and it exerts, very nearly, the same force during the time in which it goes through every part of the space it describes. The construction of the springs is expressed in fig. 41: abc are two iron bars, 5 feet 6 inches long; jointed at b , like a pair of compasses, and fastened on a pivot at a , which remains immoveable upon the frame, while the other end is also fastened on a pivot, fixed to the bolt, which carries the roller f . The bolt is 7 feet 1 inch long, and 3 inches square. It runs in two sets of four brass rollers each, at g and b , which embrace it completely, and prevent friction as much as possible. The joint b is sustained by a brass roller, which runs on the iron plate ik . Two tapering steel bars, or springs, lm, no , are fastened against the lower ends ac of the iron bars; one of them is convex at m , the other concave at o ; and they exert their force against each other at mo , where the convex one rests in the concavity of the other. There is an adjustment of the flap which carries the bolt, see fig. 1. by which it may be raised up, so as to become exactly opposite to the roller on the east, when that is raised to its highest position.

It will now be easily perceived, that when the eastern rubbing plate, in its well adjusted vertical position, is pressed against the right ascension roller, by a roller exactly opposite, and with a force sufficient to keep it firmly poised against that roller, a vertical motion may be given to the telescope, in

which the same meridional situation will be preserved. Accordingly, I find that the right ascension of unknown objects, deduced from known ones, observed by the same instrument, and in the same zone, is capable of great precision; and this construction will therefore answer all the ends that were proposed. For it would not be doing justice to the telescope to require of it all the accuracy of a transit instrument.

The spring-bolt, as I call this latter machine, is brought to any required situation by a rope fastened to the middle cross-beam of the stand, which comes down, and goes through a pulley placed upon the machine; in its return to the top, it passes over a second pulley, and then goes down to a barrel with a wheel and pinion, on the ground timber at Q'.

The polar distance machine, as I call the opposite one, on account of its chief use, which remains still to be explained, is drawn up and down in a similar manner, by the handle of a pinion, wheel, and barrel placed at R'.

In the observatory is placed a valuable sidereal time-piece, made by Mr. SHELTON, for which I am obliged to my astronomical friend Mr. AUBERT, as a gift that will always be highly esteemed. Close to it, and of the same height, is a polar distance piece, which has a dial-plate of the same dimensions with the time-piece; and is also divided into sixty parts on the outside; but these are to express minutes of space. Every tenth is marked with large figures, but every single one is also denoted with its proper figure, in a smaller character. The degrees are shewn in a square opening under the centre, and change backwards and forwards as the telescope rises or falls. This piece may be made to shew polar distance, zenith dis-

tance, declination, or altitude, by setting it differently; but in conformity with FLAMSTEED'S British catalogue of stars, I have generally adopted polar distance.

The construction of this piece is very simple. It contains only one barrel, for the weight and line, which gives motion to the work; and two small index wheels. The line is conducted from the polar distance machine into the observatory at the bottom of the polar distance clock, where it rises up, and passes over the barrel. By making this revolve, it moves the hand upon the axle of it, which points out the minutes upon the dial-plate. The hand is made adjustable in the usual way of the minute hand of common clocks, by going upon a pipe, kept firm by springs. The line is of considerable length; but the case of the clock being no larger than that of the time-piece, a set of neat and very thin pulleys, four and four, are used to draw the end, after its having crossed the barrel. It is necessary to mind, in setting these pulleys, that they should run upon very thin pivots, and clear one another perfectly; as otherwise their action might not be adequate to the purpose; this however is only to stretch the end of the line freely and sufficiently, that in passing over the barrel it may not make it turn about irregularly. There will be no occasion for a revolution of the line upon the barrel, as I have found a mere passage over it of sufficient effect in turning it; for the hands must all be properly counterpoised. Each revolution answers to one degree of change in polar distance; the minutes are therefore pointed out by the hand it carries. The two small index-plates I have mentioned, are fastened upon pivots against the back of the dial-plate, between it and the frame of the barrel. They are placed so, that their edges meet not far

from the centre of the square hole, I have mentioned, in the dial-plate, for shewing the degrees; and a small square portion, a little more of one than the other of the two wheels, may therefore be seen, in front of the dial-plate, through the opening in it.

These wheels carry contrate teeth on the inside, and a small dial-plate on the back. The face of the dial-plate of the wheel which presents itself at the right, carries the units of the degrees; 1, 2, 3, 4, 5, 6, 7, 8, 9, 0; while that on the left has a blank which remains till the 0 of the first appears. Upon the axle of the barrel, close to the frame-plate on the outside, is fixed a long counterpoised contrate pallet; which at every revolution sweeps over one of the teeth of the first wheel, of which there are ten. The shape of the pallet must be like the barb of an arrow; but more obtuse, that it may take as much time in entering very obliquely into the teeth as possible, to avoid a sudden shock. The movement will even then be found to be quite quick enough, for shewing almost instantly the proper degree of polar distance. But to counteract the sudden stroke of the long pallet, there is over each wheel a small lever, see *a b*, fig. 42. that rests with its end between the two uppermost teeth *c d*; and its shape is that of a very obtuse angle, such as 160 degrees. The point of the angle sinking down between the two teeth, by its slope both ways, prevents their overshooting. The lever is held down with a very weak spring, *ef*, the point of which touches the lever at *e*, near the place of its pivot. This method will even throw back the figure upon the dial, if it should have been overshoot a little. Care must be taken to let all this work be light, that no great force may be required in the long pallet to move it.

The first wheel in turning about carries a short pallet, of a shape similar to the long one. This must be placed low enough to let the long pallet pass freely, and high enough to clear the spring-lever in going over it. The pallet, on the appearance of the 0, strikes a tooth of the second wheel, and brings the figure 1 into view, which with the other forms 10. The second dial-plate has a blank, and the figures 1, 2, 3, 4, 5, 6, 7, 8, 9, 10, 11, 12, engraved upon its face, and presents thirteen teeth to the pallet on the first wheel, by which the blank and figures are successively brought into view, along with the succession of the units on the dial-plate of the first wheel.

In this manner the degrees are shewn from 0 to 129, which includes the whole range of north polar distance in this latitude; while at the same time they are properly subdivided into minutes. A more minute division was not thought necessary with this instrument, and indeed ought not to be aimed at.

The cord which gives motion to the polar distance clock, is rendered a just representative, or true index, of the angular movement of the telescope in the following manner.

On the machine which holds the right ascension roller, is an arm lmn , fig. 40. in an oblique direction, upon which is fastened a brass slider, 3 feet 1 inch long. A coarse screw passes from one end of it to the other, and is confined between its shoulders ln . At o there is a handle, by which the screw being turned, a small sliding plate m , which carries a pulley, is drawn backwards or forwards at pleasure, along the whole range of the slider.

On the telescope, near the bottom of the front edge of the

eastern rubbing-plate, is a small square bar with a loop upon it, which is adjustable, so that it may be occasionally brought a little nearer to the mouth of the telescope, or removed farther from it. The end of the polar distance cord is fastened to the loop upon this bar, where it remains when the polar distance clock is not in use. By this means the weight which stretches it in all its length from the telescope to where it is suspended in the clock-case, is kept always equally exerted, and no relaxation of the cord, which ought to be avoided, can take place.

When the polar distance clock is to be used, the cord is lifted into the pulley of the slider at *m*, and now goes from thence to its destination as before. The right ascension roller resting against the rubbing plate, the pulley of the slider is near at hand, and the cord may easily be lifted into it. The handle *o* is now to be turned till the cord, which goes from the loop at the telescope to the pulley upon the slider comes to cover a certain white line or mark upon the side of the tube. This line when it is first made, must be placed so as to be vertical when the radius of motion of the loop is a little more than one degree of elevation above the horizon.

The theory of this arrangement is, that when a motion in polar distance takes place, the tangent and the arch may be looked upon as equal for a few degrees, in a mechanism which aims only at minutes. And, indeed, as far as two degrees and twenty minutes, when the motion is taken equally both ways of the adjusting point, the deviation from truth will not even amount to quite one second.

The cord from the pulley of the polar distance machine passes

straight away to O' , fig. 3. where it is bent over a small pulley to one just close to it, which leads it in a direct line to P' , under the polar distance clock, where it rises up to the barrel.

The barrel is of such a diameter as to answer as nearly as possible to the length of the cord which is drawn by the motion of the telescope over one degree of polar distance; but as the utmost accuracy could not have been obtained in the make of the barrel, the loop at the telescope which draws the end of the cord, as we have described, may be slipped backwards or forward upon its bar, which will either lengthen or shorten the radius of its motion, and occasion its drawing more or less of the cord.

As there is a good quadrant upon the telescope, there remains nothing else to obtain a just position of this loop than to compare the indication of the polar distance piece with that of the quadrant; and when the former is regulated to a perfect agreement with the latter, we may safely rely upon the truth of its report.

The time and polar distance pieces are placed so that the assistant sits before them at a table, with the speaking-pipe rising between them; and in this manner observations may be written down very conveniently. The place of new objects also may directly be noted, as their right ascension and polar distance is before the assistant upon the table, where nothing is required but to read them off, on the signal of the observer.

By a catalogue in zones the assistant may guide the observer, who is with his back to the objects he views, and who ought to have notice given him of such stars as have their places well settled, in order to deduce from their appearance the situations of other objects that may occur in the course of

a sweep. In the year 1783, when I began this kind of observations, no catalogue of stars in zones had ever been published; I therefore gave a pattern to my indefatigable assistant, CAROLINA HERSCHEL, who brought all the British catalogue into zones of one degree each, from the 45th degree of north polar distance down to the horizon, and reduced the right ascension of the stars in it to time, in order to facilitate observations by the clock. [This catalogue was afterwards completed from the same degree up to the pole in zones of 5 degrees each; and the variation in right ascension from one degree of change in longitude, was also reduced to time, for every star in the catalogue. To this were added computed tables for carrying back present observations to the time of that catalogue; which method I preferred to bringing the stars it contains forward to the present time, on account of conforming with the construction of the Atlas Coelestis, which was of great service.

The evident use of such a catalogue must undoubtedly soon have been perceived by every person who was acquainted with the method I used for sweeping the heavens; and as the same is practicable, not only with my telescopes, but likewise with transit instruments, and mural quadrants, we are now much indebted to the Rev. Mr. WOLLASTON, who in the year 1789 favoured the astronomical world with a work of nearly a similar construction with that which I was in the habit of using; but much enlarged, and enriched with stars taken from the best authors; and moreover reduced to the time of the year 1790.

We now seem only to want an atlas on the same construction, upon a scale equally extensive, and plentifully stored with well ascertained objects.

The micrometer-motion which is required for sweeping the heavens, and indeed for viewing the planets or other objects, is obtained by means of the end of the rope B, fig. 37. which draws up the telescope. This goes down to a barrel, S', fig. 3. 12 inches long, and 4 in diameter, joined upon the same axle with another barrel, 12 inches long, and 12 in diameter. A smaller rope goes from the largest barrel into the working-room, where it is fastened to the top of a thin vertical spindle, 2 feet 6 inches long, and 3 inches in diameter, at *a*, fig. 43. Another rope of equal size is fastened to the bottom of the same spindle at *b*; and when by turning the handle *cd* the rope *ae* is wound upon the spindle one way, the rope *bf* is wound off the contrary way. This second rope *bf* goes out of the work-room over a pulley, which leads it upwards to the top of the middle cross beam of the ladders, where it descends over another pulley, by a weight with shifters which is suspended to the end of it. In this manner a balance is obtained between the stress of the ropes *ae* and *bf*, which leaves the spindle at rest in any position where it may chance to stand, and considerably eases the labour of the workman, who turns this handle a certain number of times one way, and then the same number of times back again. By such a motion of the handle the telescope is alternately depressed and elevated; and this being continued for as long a time as the observer chooses, enables him to review the heavens as they pass by the telescope.

By the arrangement of the barrels, it is easy to see that the motion is sufficiently divided; as many turns of the handle are wanted to pass over a small space of the heavens. The method of barrels and ropes is to be preferred to wheel-work, on account of the smoothness as well as silence of the motion,

both which in observations of this kind are highly necessary. It is true that the great stress which lies on the ropes of the micrometer-motions wears them out very fast, and they must therefore be carefully watched, and often renewed; but this ought to be no objection where the end to be obtained is of such consequence.

It would not only be troublesome to the workman, but often bring on mistakes, were he to count the turns of the handle, which perhaps for hours together he is moving; a zone-clock, therefore, has been contrived to release him from that care. This is a machine which is placed upon a table just by the workman. It strikes a bell when he is no longer to turn one way; that is, when the telescope is come to one of the limits of the zone, which if it be after going down, is called the bottom bell; and it strikes another bell when he has made the same number of turns in a contrary direction. The telescope is by this motion restored to its former situation, and this second notice is called the top bell; which marks out the other limit of the zone. These bells not only give notice to the workman when he is to change, but their different sound indicates the position of the telescope, and prevents mistakes.

An additional precaution has been used, to make the bells repeat their stroke, the very next turn, if by some mistake the workman should have been inattentive to the first notice. In a long continuation of uniform intervals of sound, we may become so used to them as hardly to perceive them at all; but the coming in of an additional sound will immediately rouse the proper attention. Another very necessary use which I have often made of a second or third bell, is to extend the zone, either towards the north or south, for some time, when

notice has been given of a star that was a little above or below the sweep ; for in some parts of the heavens known stars are scarce, and it becomes necessary to take in all those that may be come at.

The construction of the zone-clock is very simple and convenient. The end of the axle which holds the double barrel, fig. 3. must be left projecting at T' . Upon this a small hollow cylindrical pipe is placed, which holds the end of the cord that is to move the zone-clock. The pipe must be guarded at both ends like a clock barrel, to keep on the cord, but remain open at the end which goes upon the axle, upon which it must fit upon a square so as to keep firm. It should be about $1\frac{3}{4}$ inches long, and 1 in diameter.

From this piece the cord is made to pass to the work-room, where it rises up into the clock at a , fig. 44. It then passes over a large narrow barrel, $b c d$, and by means of a weight w at its end, descends when the handle of the micrometer-motion turns the spindle and double barrel with which the pipe that holds this cord is connected. At $c b$ are two levers that, in the usual way, occasion the hammers $e f$ to strike the bells $g h$, when the pins quit the levers which they have lifted up. But these levers have spring joints, so as to permit the pins to pass back again without disordering the work. The pins which move the lever c are fastened to the barrel $b c d$. The lever b must be brought out so as to be before the front of the first frame-plate, and close to a dial-plate, which is to contain about 40 numbers. The dial-plate must be pretty thick, and be fixed upon a hollow arbor. The axle of the barrel, which should be strong, must be long enough to come through the hollow arbor, and project a little way to receive a milled nut

upon its end, which must have a screw upon it. The arbor which carries the dial-plate is then to be pinned fast upon the axle, and an adjustable hand being put upon the projecting arbor, a collet is slipped over it, and the milled nut screws it down, in any position that is to be given to it.

The adjustable hand is made of a piece of springy iron, or steel, formed as represented at *ik*; but broader than clock hands usually are. It must have a pretty large circle in the middle, with a hole wide enough to go upon the plate-arbor. The end *k* of the hand must project beyond the dial-plate a little way, so as to permit two screws, *m n*, to pass by it into a brass plate, with a small piece between, to allow some motion up and down to the hand. The plate which is fixed to the hand by the screws *m n*, returns under the dial-plate sufficiently to carry three pins that are to lift the lever *b*, when they come to the proper situation, in the same manner as those on the barrel lift the lever *c*. The dial-plate, close to the margin, should have as many small holes, to receive a pin, as there are numbers marked upon it; and in the hand, answering to the holes, must be fixed a steady pin to fall into any one of them, when the hand comes to be placed over it. There must be a small handle near the end *l* of the hand, by which it may be lifted up, and moved into any situation that shall be required; and care must be taken to have both ends properly counterpoised.

In order to set the zone-piece to the breadth of any particular sweep, as for instance two degrees, we make the workman begin at the striking of the top bell, and while he turns the handle till the quadrant or polar distance-piece points out a change of two degrees, we keep the hand of the zone-clock lifted up, that the pin may be out of the holes upon the dial-

plate; for which purpose also the nut in the centre must be unscrewed a little to permit it to pass freely. When the telescope has descended two degrees the workman must stop the handle. We then lift the hand to the place where the first pin strikes the lever of the bottom bell. Here we let the pin drop into its proper hole, and screw fast the central nut. When this is done, the workman may turn backwards and forwards from bell to bell, and the telescope will perform the required motion of two degrees.

The work of the zone-piece is arranged in such a manner as to make the numbers on the dial-plate answer to turns of the working handle: this however, though convenient, is not absolutely necessary. The number of turns to a degree varies a little in different altitudes; but by trial a table may be made, which will shew with sufficient accuracy the figure on the dial-plate to which the hand must point, that the zone-piece may give any required breadth to a sweep, at any certain polar distance.

By means of the speaking-pipe the workman may be directed to begin, to stop, to go fast, or slow. And these, with a very few other orders, will be all that are wanted; which being known to him and to the assistant, will occasion no mistake, notwithstanding the pipes which go into the two apartments are united.

The ropes that come from the gallery, each bracket of which is separately drawn up, go through a double pulley, hung to the top cross beam, and a double pulley fastened to the upper end of the gallery bracket; after this they pass over a single pulley at the top, down to two barrels placed under the back of the ladders, one on each side. Each barrel is moved

by a handle, on the axle of which is fixed a pinion of four leaves: this works in a wheel, on one side of the barrel, of 61 teeth, and 18 inches in diameter.

The barrels are $25\frac{1}{2}$ inches long, and 12 inches in diameter, that the rope may not be doubled often, which might hurt the uniformity of drawing up the gallery. They are made exactly alike, and draw an equal length of rope at every stroke of the handle; but as one of the persons who draw the gallery might go on quicker than the other, each of the handles strikes a bell at every turn, going up as well as going down; the different tone of the bells easily shews, by sounding in regular alternate succession, when the gallery is properly moved; which therefore may be safely done in the dark. The mechanism of the bell-work at each handle is in a little box, to keep it dry, but sufficiently open at the side to throw out the sound.

A single bell being suspended, as in fig. 45. upon a plate of iron, at *a*, there is a cock, *bc*, planted upon it; between which, at *d* and *e*, are inserted two axles continued outwards. On the outside of the cock, and upon these axles, are two inverted hammers suspended, with lever arms, *fg*. These are made with spring joints, like those that have been described in the zone-clock. The axle which moves the barrel has a pallet upon it, and the plate with the bell apparatus being presented at rectangles to the axle, so as to make the pallet play in the notch of the plate between *f* and *g*, where the lever arms meet, it will make the bell give a stroke, either with one hammer going up, or with the other coming down.

It is necessary to preserve the pliability of the ropes, for which reason no tar has been used with any of them that are about the telescope. To preserve them, however, they are

passed through very hot melted tallow, and kept a sufficient time immersed in it, that they may be thoroughly penetrated. In this state they will last a considerable time, especially when care is taken not to relax them often. The gallery being suspended by ropes in this state, it would be unpleasant to trust entirely to them. Each bracket therefore is furnished with four strong broad iron hooks, two of which take hold of one of the flats of the division $\beta\gamma$, fig. 7. while on the opposite side two more take hold of the corresponding flat of $\delta\epsilon$. When the gallery has been drawn up to the required altitude, the hooks are let down, and the ropes slackened a little, so as to permit it to hang in the hooks. The other two hooks on each side serve for an elevation between the flats half way from one to the other. They are upon the same centre with the former, and fall back as the others do when the gallery is to go down.

For the safety of the tube also, there is a strong chain, which will sustain it, in case the ropes by which it is suspended should give way. This is fastened into a loop near the point of suspension. The other end of it is hooked upon a flat, and passes round one of the side beams of the ladder at a certain elevation above the telescope, and is sufficiently long to permit the tube to move a few inches more than is necessary. By this means a fall can never be considerable: if the ropes were to break in the worst part of a sweep of $2\frac{1}{2}$ degrees broad, the telescope would hardly descend two feet.

The construction of the great mirror is as in fig. 46. The metal itself is $49\frac{1}{2}$ inches in diameter, but on the rim at ab is an offset of $\frac{3}{4}$ inch broad, and 1 inch deep, which reduces the concave face of it to a diameter of 48 inches of polished sur-

face. The thickness, which is equal in every part of it, remains now about $3\frac{1}{2}$ inches; and its weight, when it came from the cast, was 2118 pounds, of which it must have lost a small quantity in polishing.

An iron ring, $49\frac{1}{2}$ inches in diameter within, 4 inches broad, and $1\frac{1}{8}$ thick, has at the face of it on the inside a strong bead or rim added to its thickness, which fits the offset in the speculum, but is not quite so deep as that. A cross of the same substance of iron as the ring, goes over its back, and when the speculum is placed into the ring, so as to rest upon the offset, the cross over the back confines it in the ring. By the addition of a thin cover of sheet iron on the back, and another of tin on the face, the rim makes a complete case for the mirror.

Three strong handles are fixed against the sides of the ring, by which the speculum may be lifted horizontally, or using only one of them, vertically, as occasion may require.

To put the speculum into the tube, there is provided a small narrow carriage, going upon two rollers. It has upright sides, between which the speculum, when suspended vertically by a crane in the laboratory, is made to pass in at one end, and being let down, is bolted in. The carriage is then drawn out, rolling upon planks, till it comes near the back of the telescope. The tube must be put back as far as the bar-machine will permit it to go. Two beams connected together so as to form a parallelogram of 8 feet 6 inches long, and 2 feet broad, are sloped away on one end, while the other contains two hooks, by which it may be hooked into two holes at the end of the foundation timber, fig. 3. in the middle between the rolling beams *r s*. This affords a passage of an easy ascent to

the speculum carriage, which must now be brought into a proper position for rolling up. When this is done, the carriage is to be tied to the axle of the point of support, A B, fig. 34. and by turning the bar-machine handle, the speculum with its carriage will be drawn up to the foundation beams E E, A A, fig. 3. which are 16 inches above the foundation wall. By the time that the carriage comes near to the top, there will be room for six 3-inch planks that are provided, to be laid one after another upon the rolling beams *rs*, which will form a platform of 5 feet 10 inches by 5 feet 5, for the reception of the carriage. But these planks must not be put down till the telescope has been first brought back, and fixed again close to the carriage, which must be sustained in its place while this is doing. Then, advancing again, the platform is laid down, board by board, till completed, while at the same time the carriage will be drawn upon it.

As soon as that is safely landed, a strong rope is to be hooked into a loop, fixed upon the beam at *a*, fig. 15. This going down to a pulley with a swivel hook at the bottom, which is put through one of the three handles of the speculum, returns to a pulley hung upon the hook *b*. From that pulley it goes forward to a leading pulley at V', upon the foundation timber, fig. 3. This directs the end of the rope to the barrel, which serves for the great round motion of the whole telescope. When the handle of that machine is moved, the speculum will be lifted up in its carriage, which being eased, must now be turned about while the mirror is yet partly resting upon it, so as to become parallel with the back of the tube, and close to it. As soon as the mirror is fairly suspended, the carriage must be unbolted, and drawn sideways from under it.

At the same time the platform must be gradually removed, that the tube may be brought back by the bar-motion, whenever the mirror is high enough to pass over the back of it. Then letting down gently the round motion handle, and guiding the mirror properly, it is to be placed upon a small hollow square, with a sloping back, which is planted under its support. The height of the square frame is such as will bring the centre of the mirror into the centre of the tube; and the sloping back receives it in going down, and throws it from the back of the tube, just as much as is required to make the adjustment at the top act properly.

When the mirror is in its place, two loops which are prepared are to be screwed fast to it. They contain the collets that receive the adjusting screws from the back, through the strong upper bar *c g*, fig. 34. and as soon as these are fastened the pulleys may be unhooked, and all the apparatus that has been used removed. The six planks are then to be laid upon the same rolling bars at *n o*, where a passage across the work is wanted, and where they may remain till zenith sweeps require them to be moved.

The method of preserving the speculum from damp is by having a flat cover of tin soldered upon a rim of iron, about $1\frac{3}{4}$ inches broad, and $\frac{1}{8}$ thick, the diameter of which is equal to the iron ring which holds the speculum. Upon the flat part of the rim is cemented, all around, some close-grained cloth of an equal breadth with the rim. The cover has two handles near the upper end, and under them two flaps that project about an inch and are six inches broad. When the cover is hung or laid upon the speculum, so that the two flaps are close to the ring which incloses it, the rim of the cover, as far as it

is lined with cloth, will rest against the edge of the iron ring, and fit it all around very closely.

In six places are painted white marks which divide the circumference equally ; and six claw-screws are provided, of the shape that is represented in fig. 47. These are applied to the six marked places. The end *a* being put over the iron ring *b* to take hold of the back, the screw *c* is then fastened so as to press upon the outside of the cover and rim, till the lining of it is brought into close contact with the iron ring.

To take off and put on again the cover, a small ladder is provided, which being set at the outside against the back of the tube, the person who is to uncover it goes up, and descends into the tube by means of a board with steps. This board goes across the mirror in a parallel direction with it, and being narrow, does not interfere with the work of loosening the screws to take them off. When they are removed, the person comes out of the tube the same way, still leaving the speculum covered, but when at the top of the ladder brings out the inside board-steps. The two handles of the cover now present themselves at the back, so that two persons can easily lift it off, without suffering it to touch the mirror in any place. It must then immediately be carried into the observatory, and remain there till the mirror is to be covered again ; but first of all the inner and outer cover of the tube ought to be carefully closed up.

When the speculum is to be covered again, great care is required to see that no drops of dew may fall from the outer cover of the tube upon the inner one ; or at least that these may not find their way to the mirror ; and to let the first

object be to put its own cover upon it before any thing be done about fixing it there.

In very high observations the tube will not fall down again readily, and in the zenith, by its great weight added to that of the mirror, will even tilt backwards. A counterpoise therefore is applied by a meridional post, 7 feet high, well fastened by a frame in the ground; and placed about 20 yards from the front of the telescope. To this is fastened at the top on the back an arm, which carries a pulley, and at the bottom on the front, a barrel moved by a wheel and pinion. A rope with a weight fastened to the end of it, goes over the pulley on the post, and towards the mouth of the telescope. At the end of the tube on each side is a loop, into which a chain is hung with both ends. It is long enough to go round the seat to a considerable distance, and holds a pulley in the middle, over which the rope from the weight is made to pass back again to the barrel at the post. Here it may be drawn up till the weight is lifted sufficiently to keep the telescope steady, and to make it fall again, when its own motions lower it. In zenith sweeps 300 weight are required for that purpose, but one hundred of that quantity is in shifters that may be taken off in lower altitudes, when less is sufficient.

A similar post and apparatus is fixed about the same distance from the telescope towards the north, to be used when the instrument is turned about for high observations in the northern meridian.

Another inconvenience to be removed in very high altitudes, is that the long bars, which bring the point of support forwards, begin to project beyond their supporters. When this

Fig. 1.

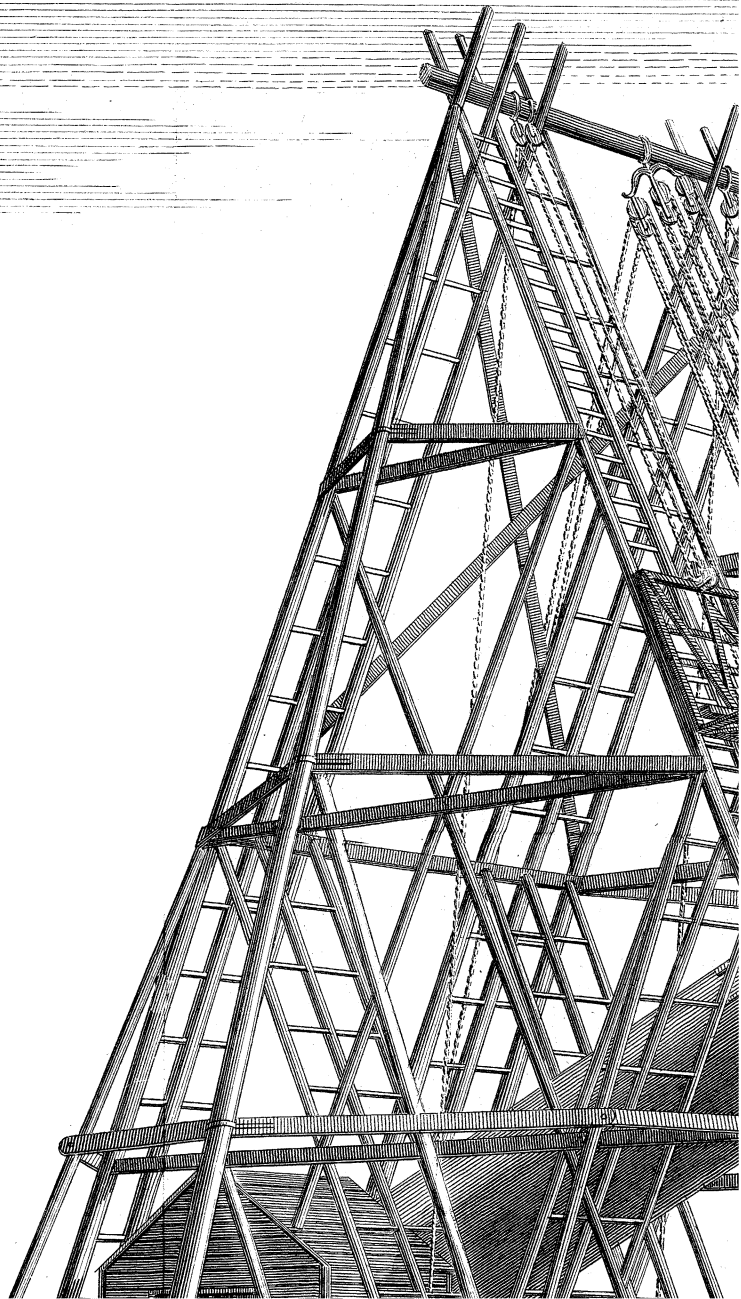

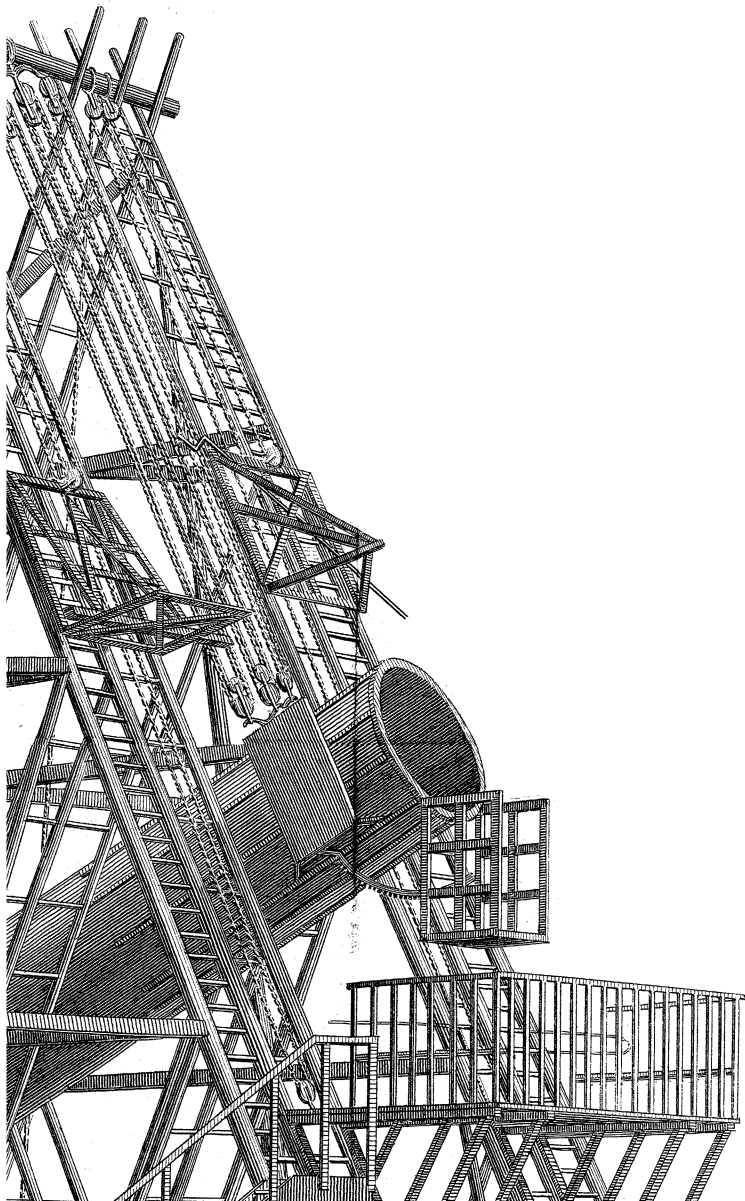

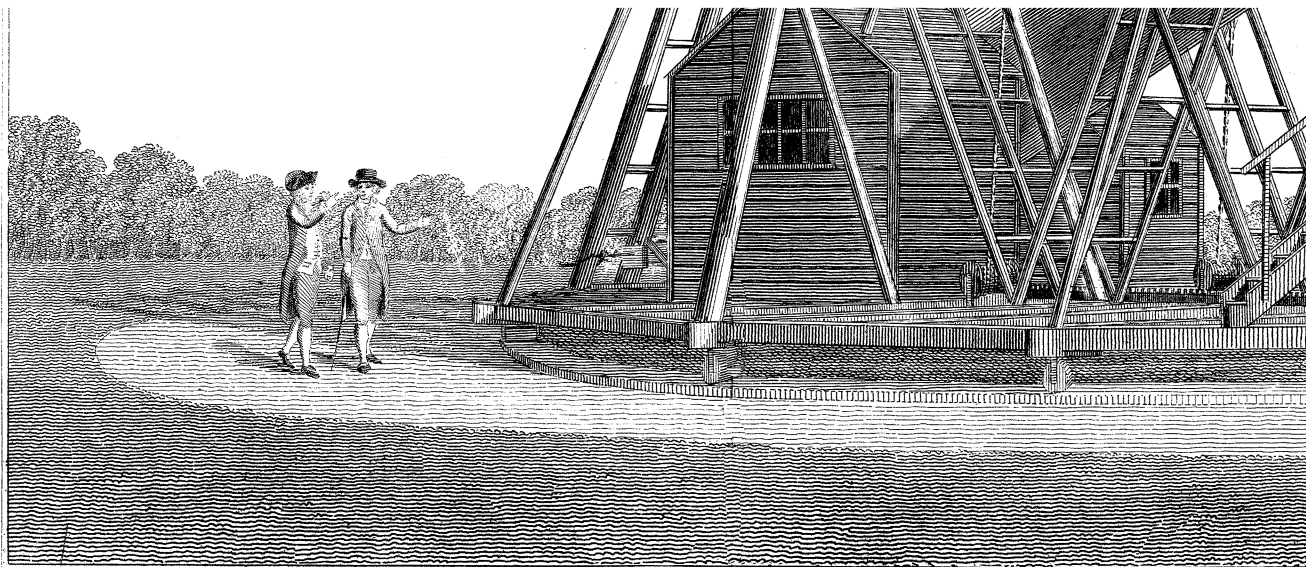

TO GEORGE THE THIRD KING

*This View of a Forty Feet Telescope, con-
sists with permission, most humbly inscribed, by his M.
and most grateful obedient Serv^t*

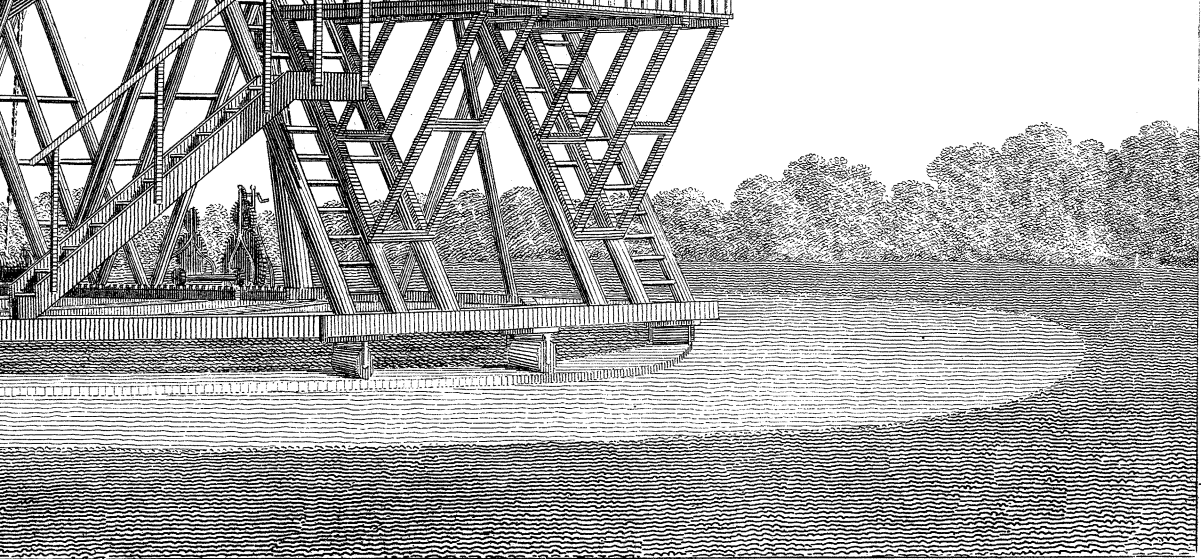

ING OF GREAT BRITAIN &c.

constructed under his Royal Patronage,
Majesty's very devoted and Loyal Subject,
Servant, William Herschel.

Fig. 2.

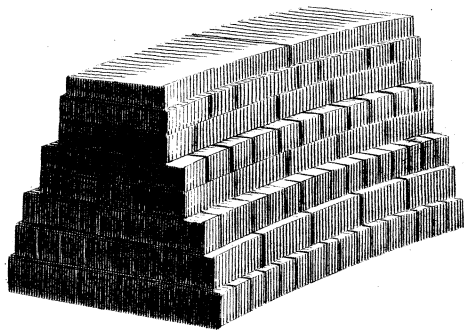

Fig. 4.

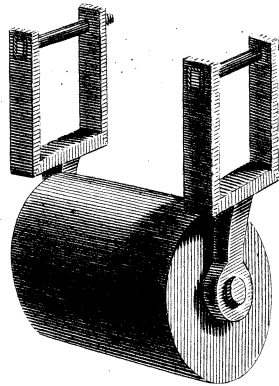

Fig. 5.

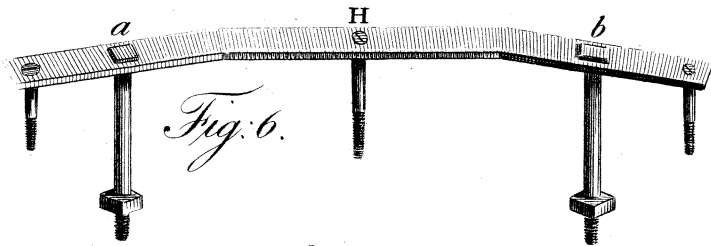
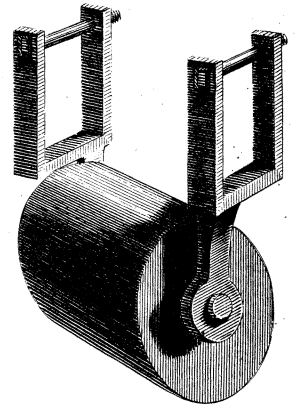

Fig. 6.

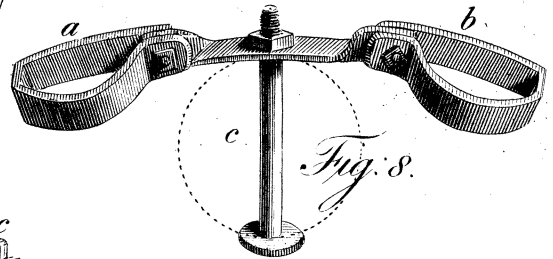

Fig. 8.

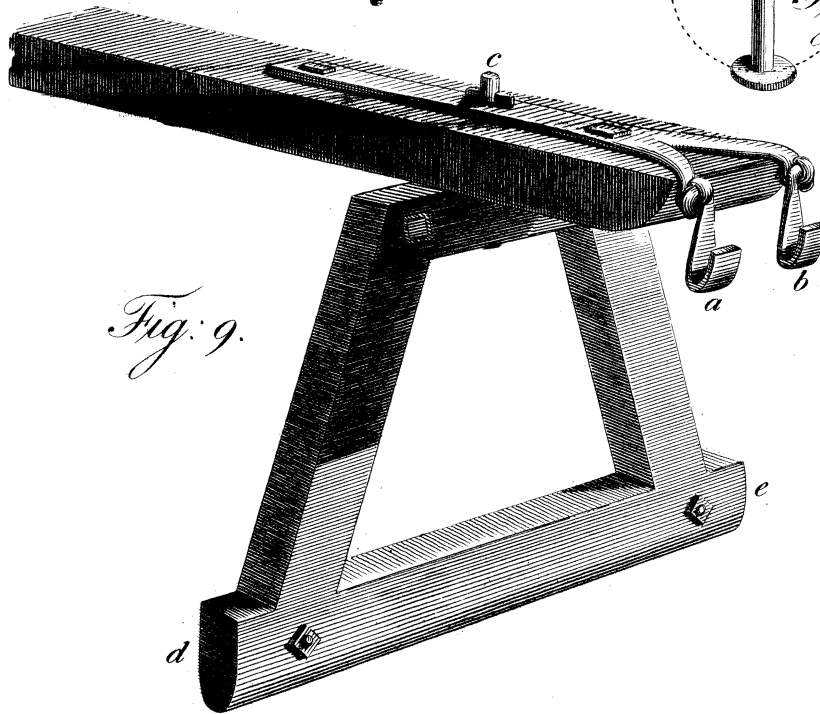
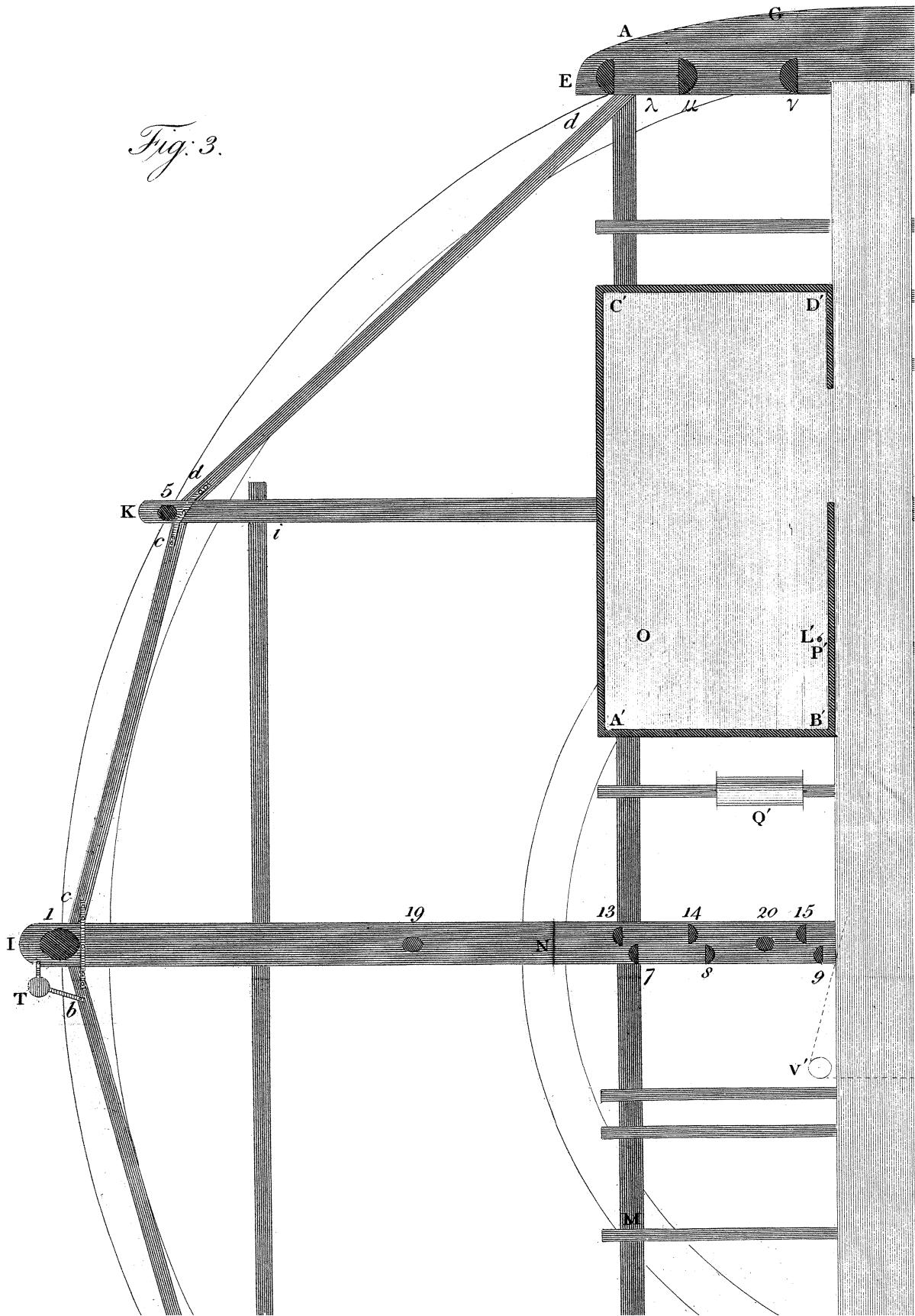
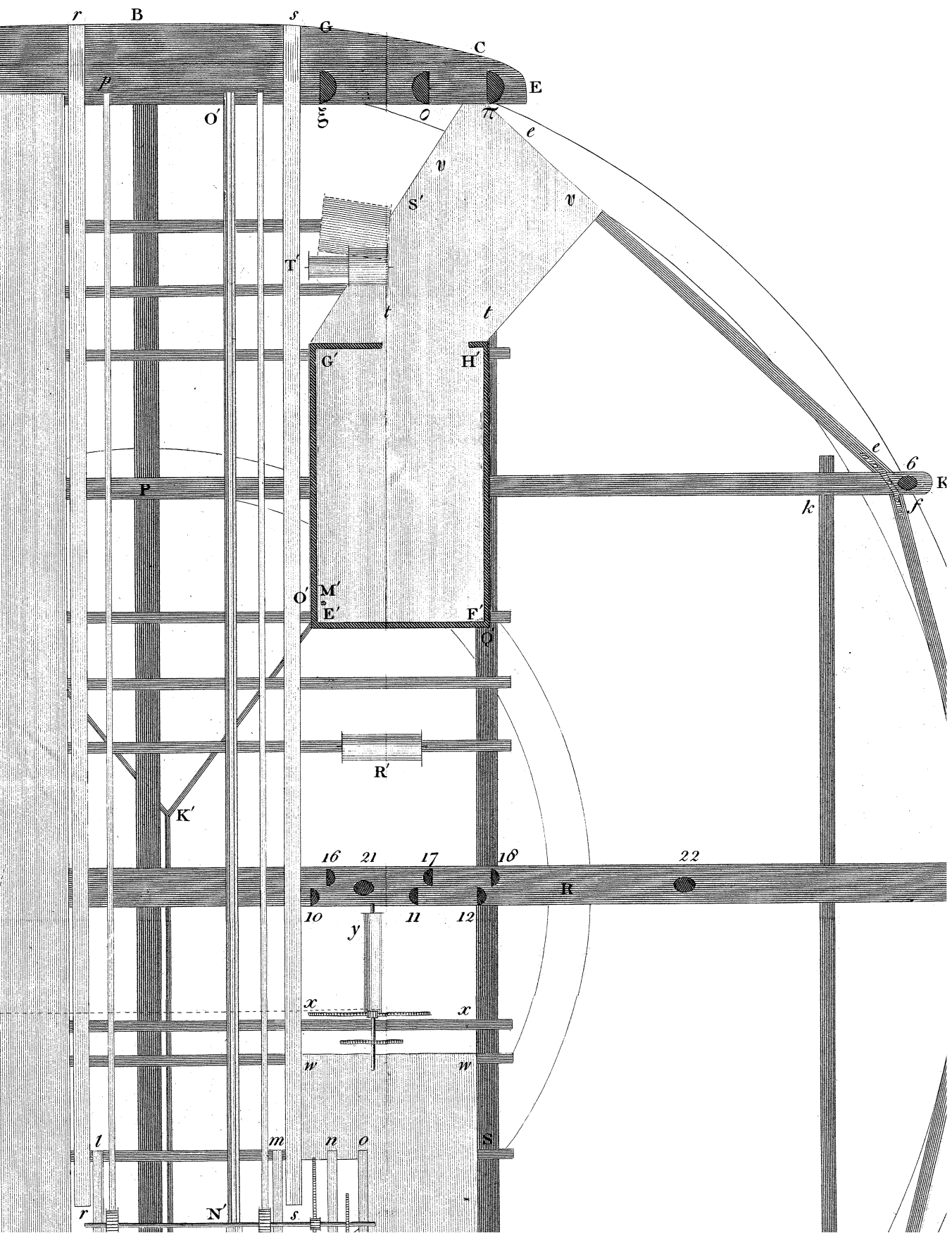
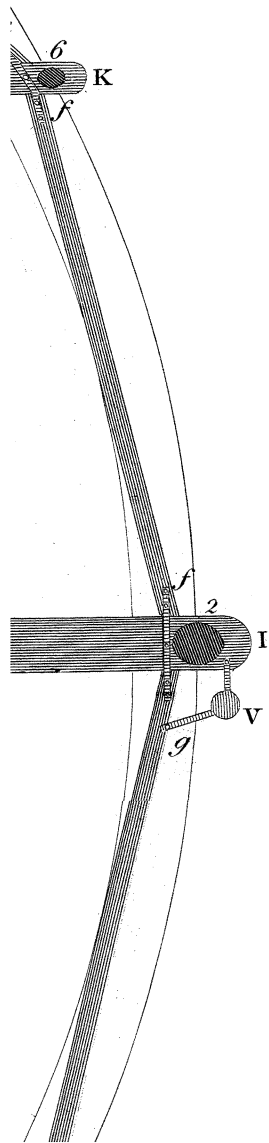

Fig. 9.

Fig. 3.







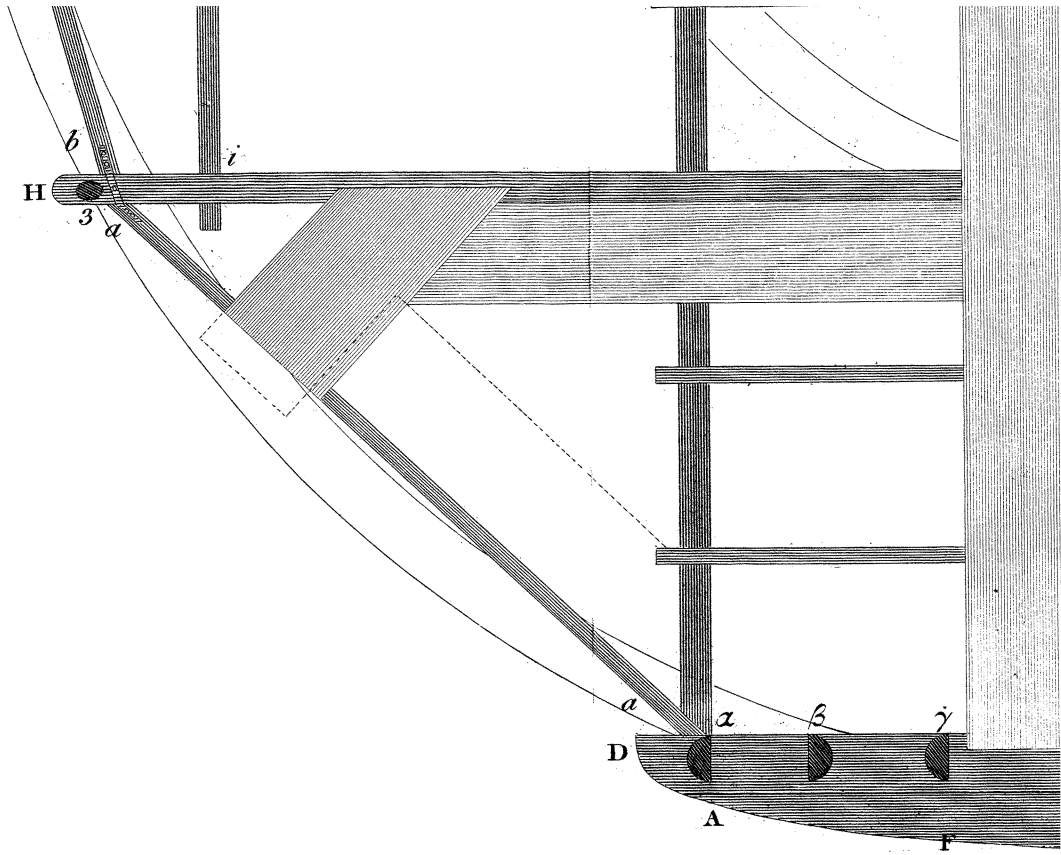

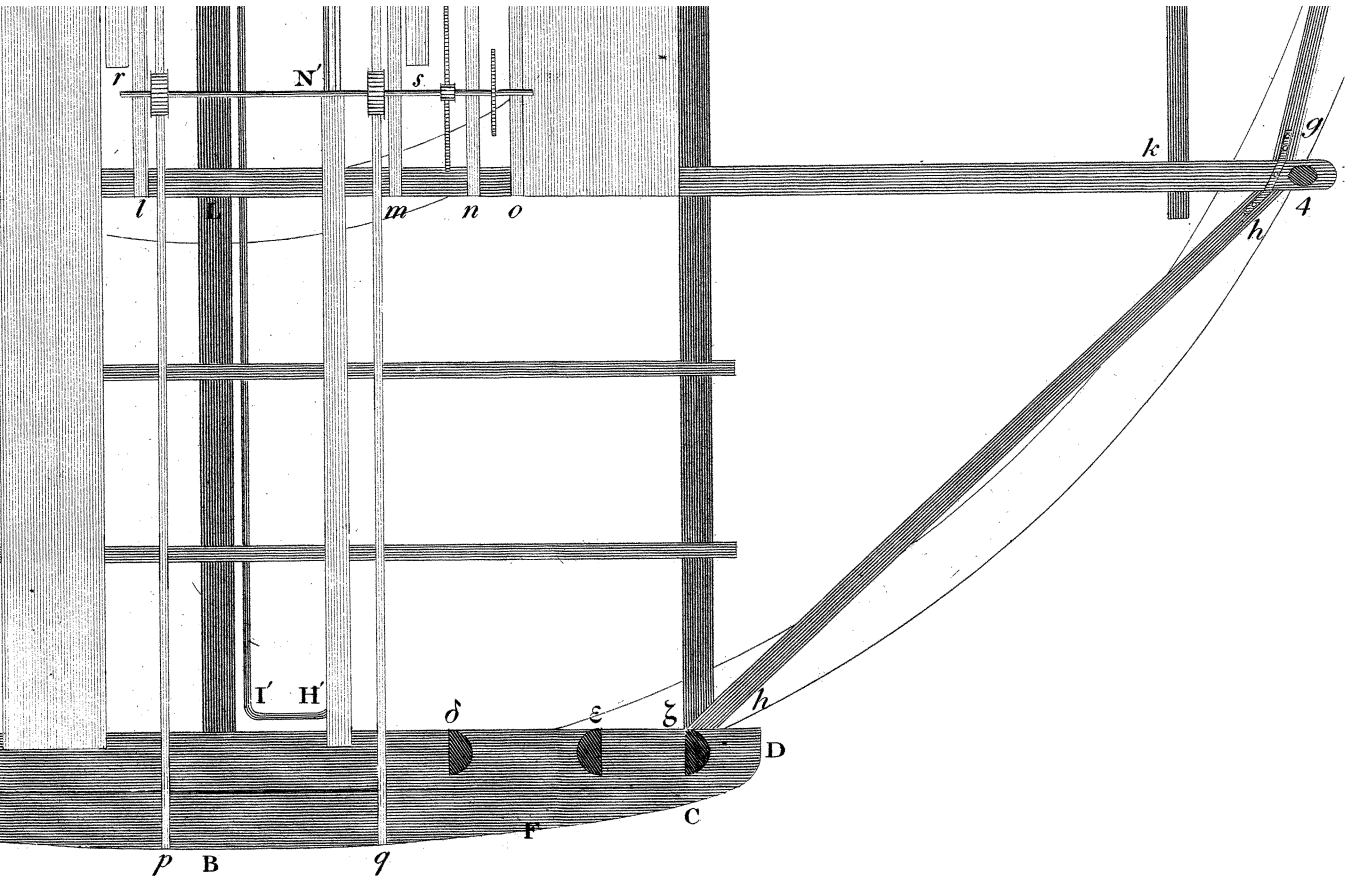

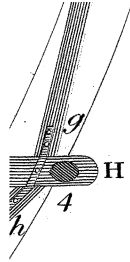

Figure 2.

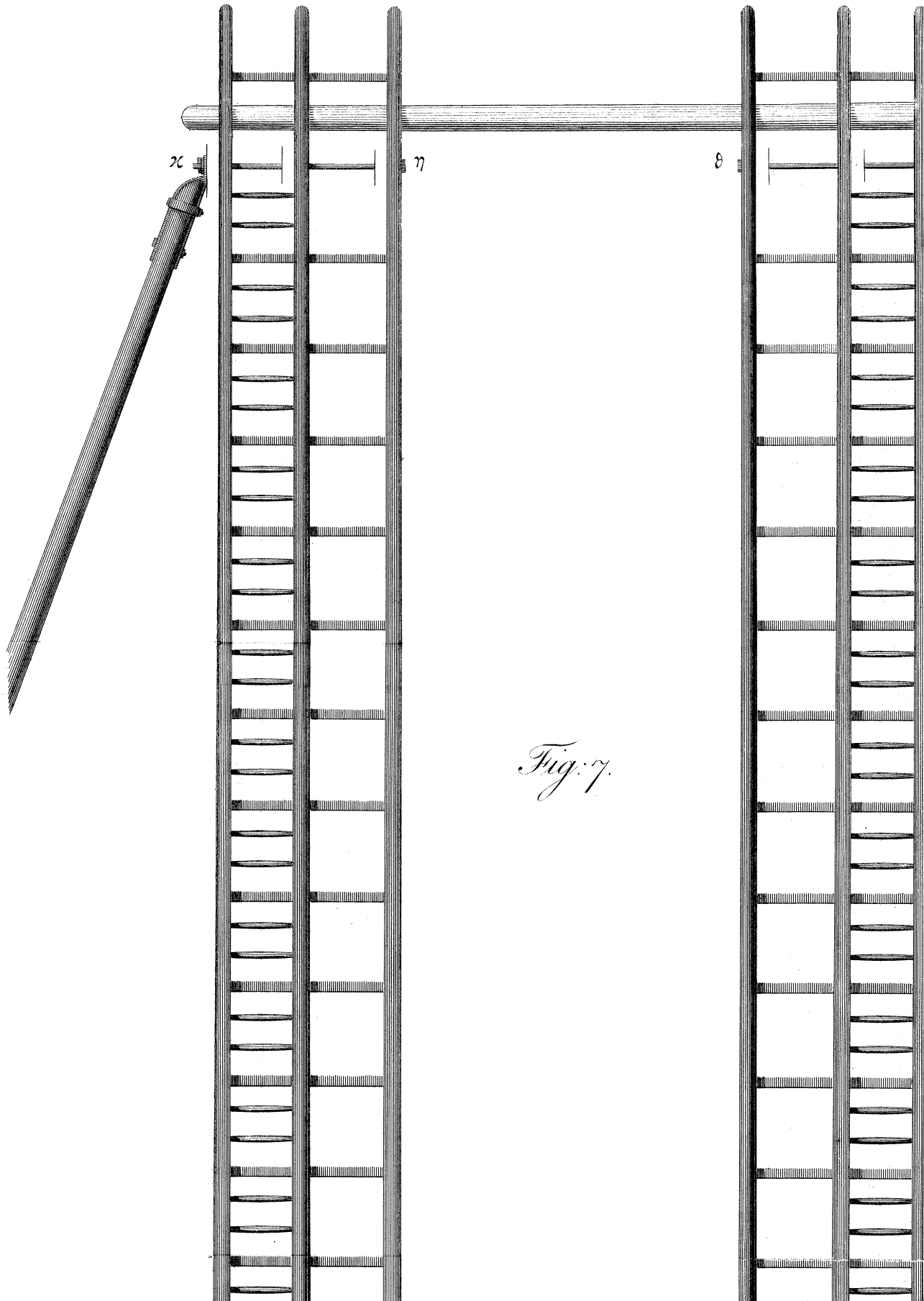
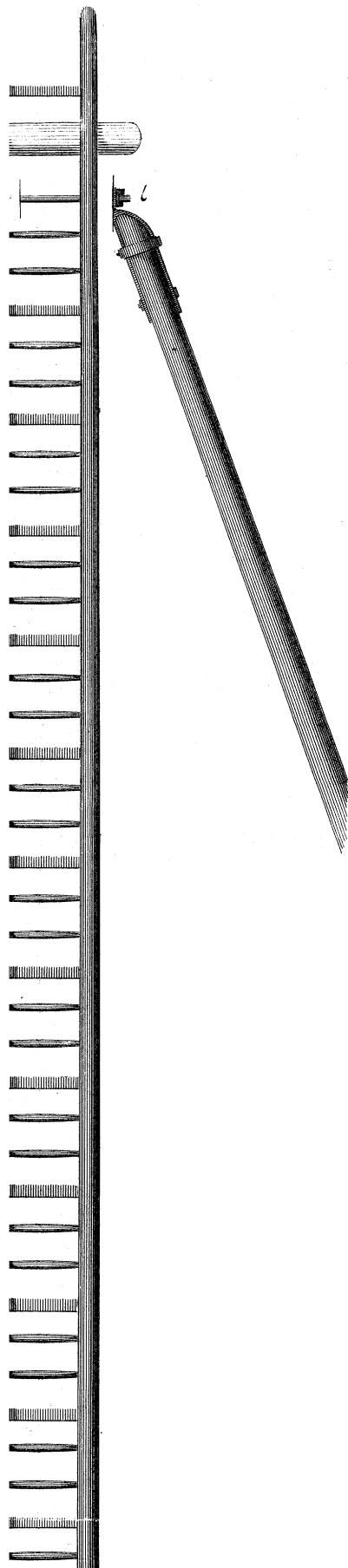
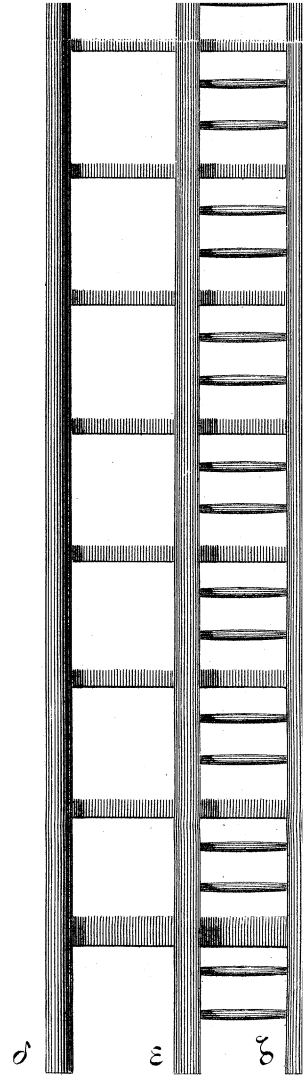
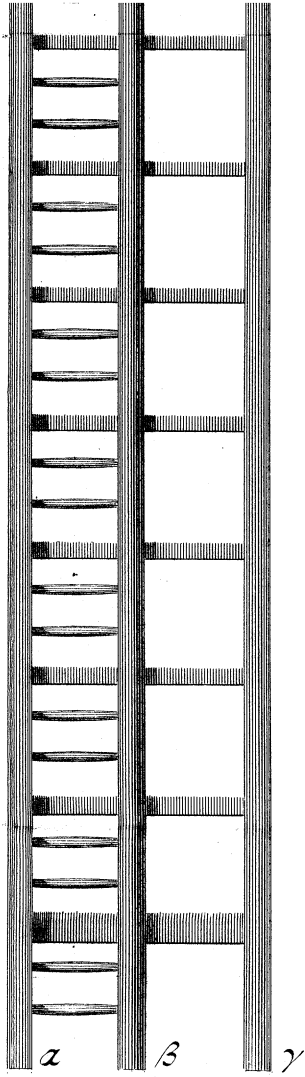

Fig: 7.





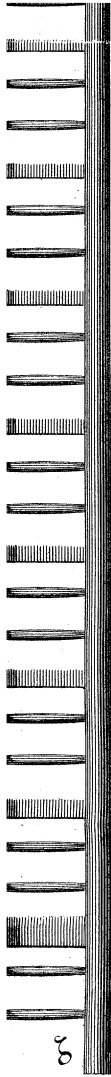

Fig. 18.

Fig. 10.

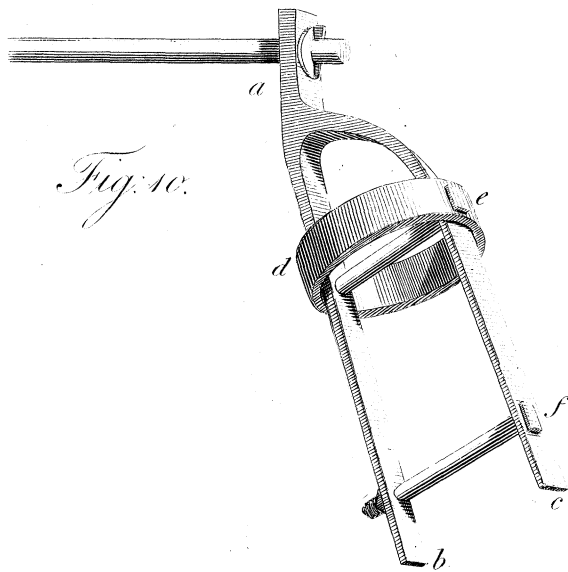

Fig. 12.

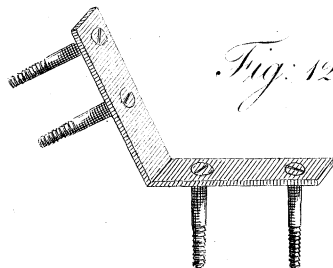

Fig. 11.

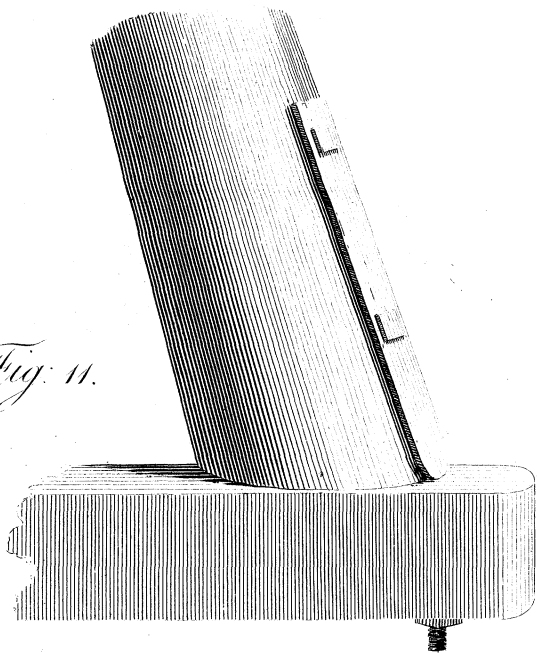

Fig. 14.

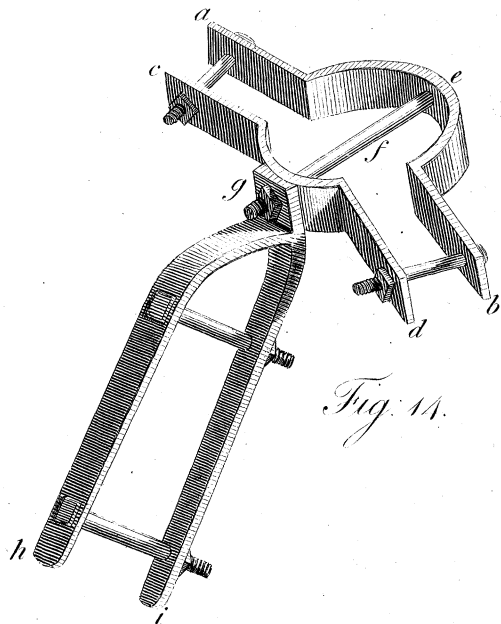

Fig. 13.

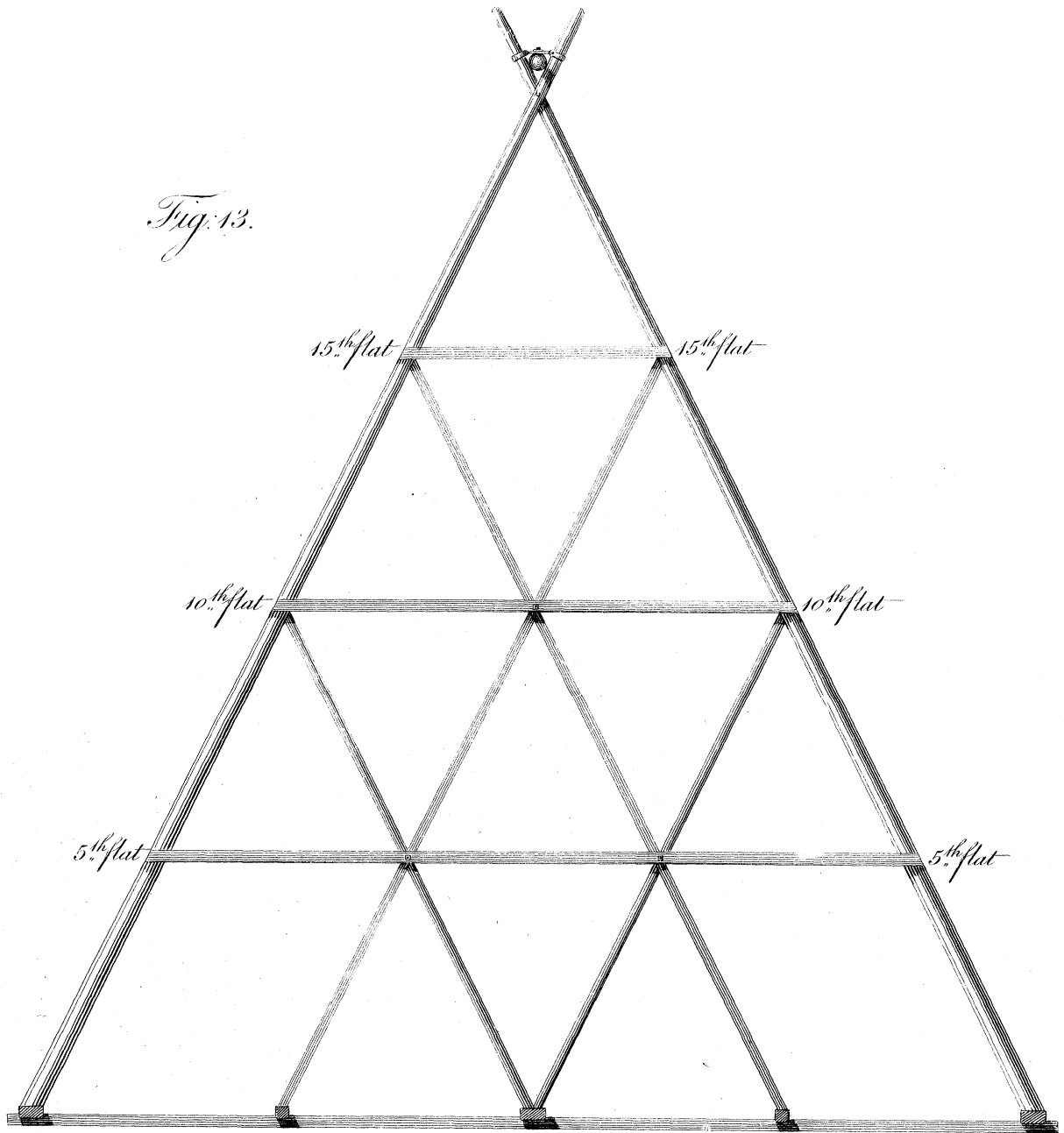

Fig. 15.

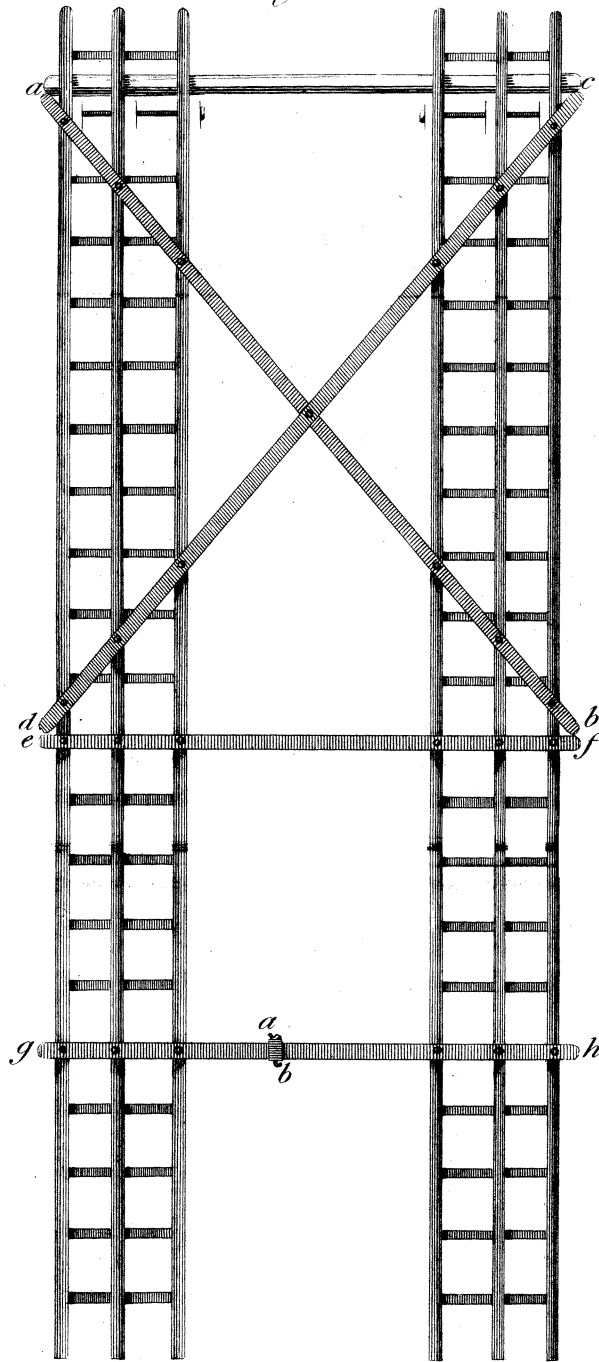

Fig. 16.

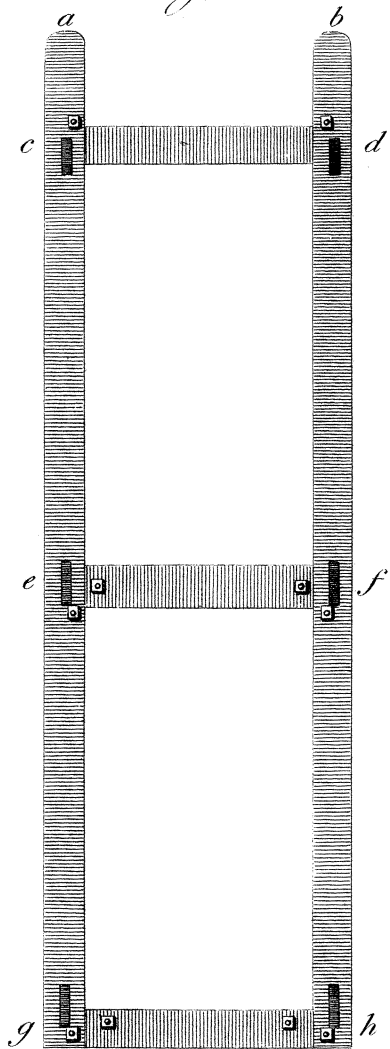

Fig. 18.

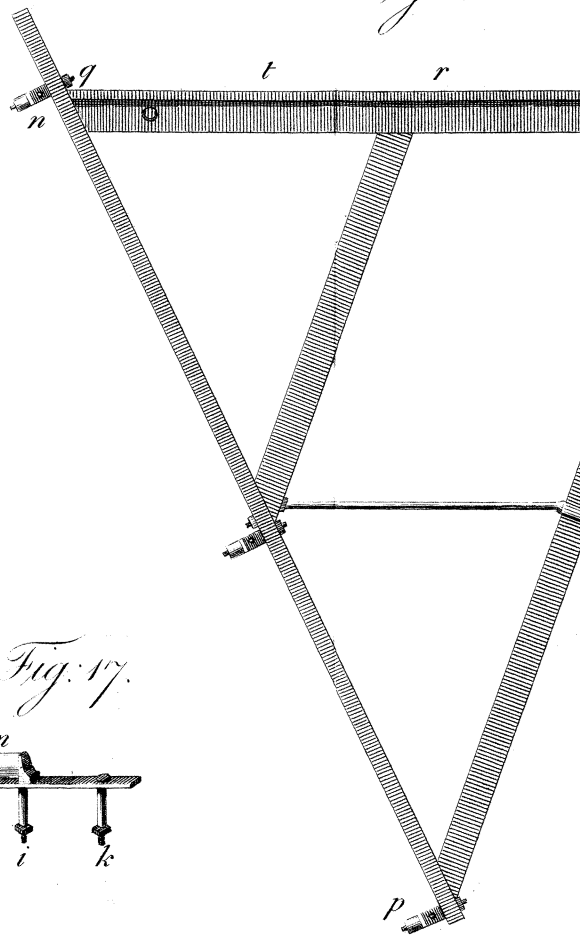
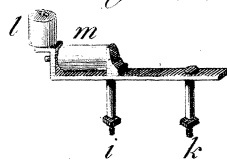
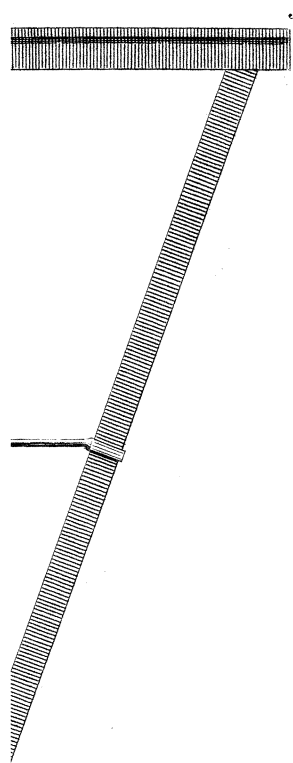

Fig. 17.





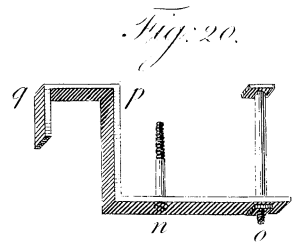
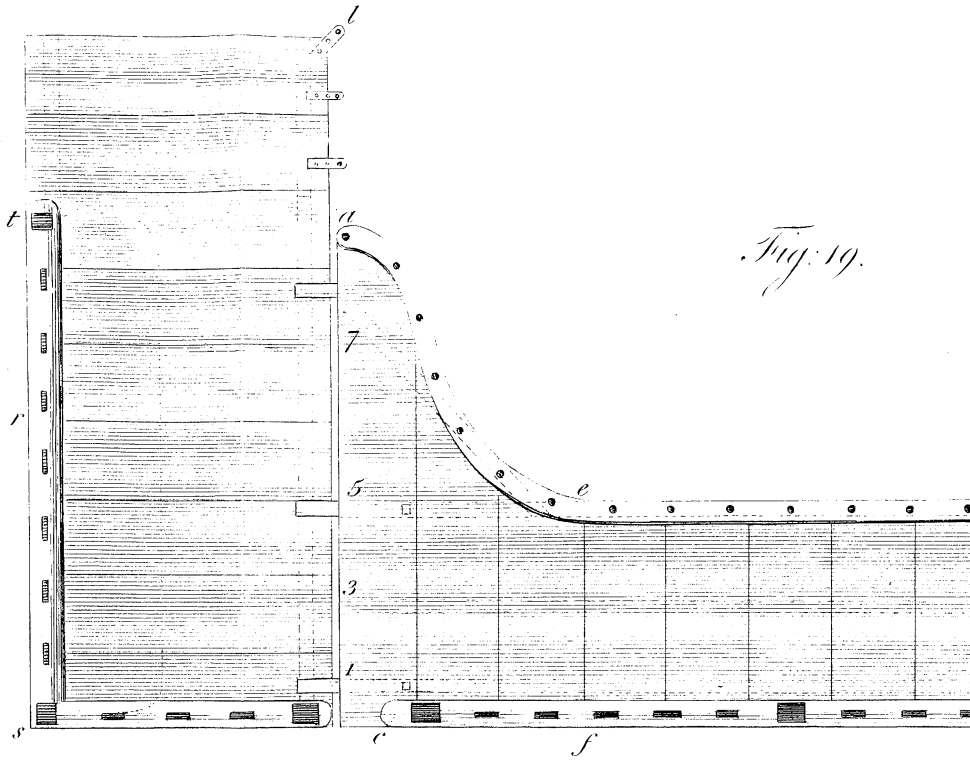

Fig. 19.

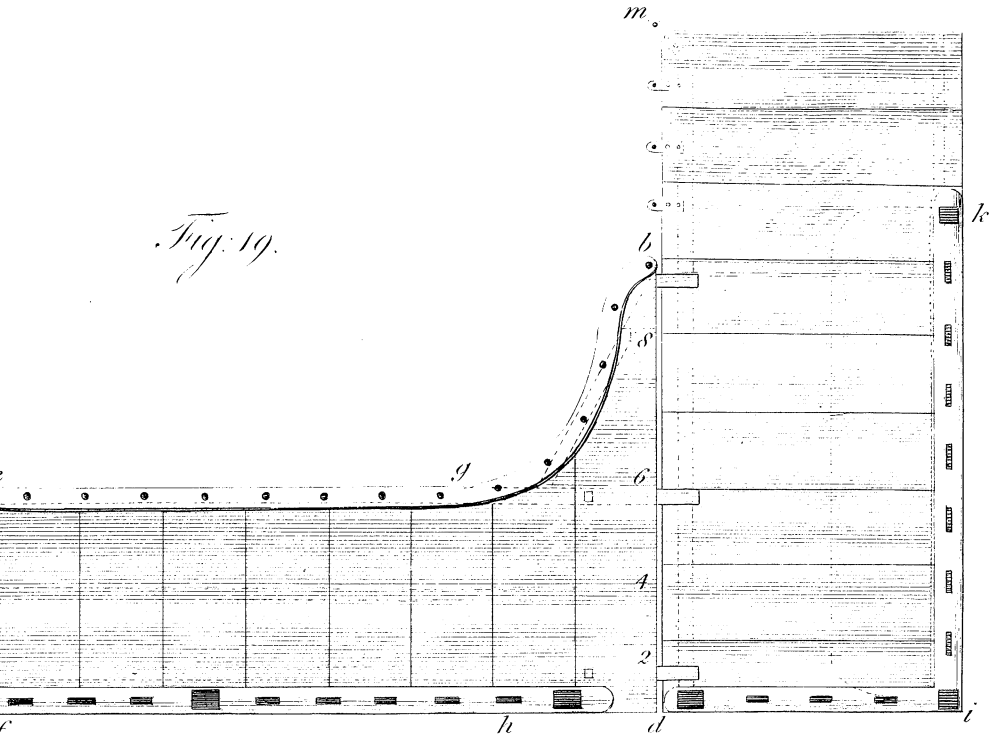

Fig. 20.

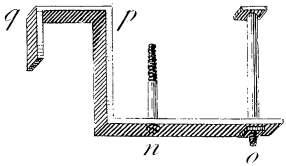

Fig: 21.

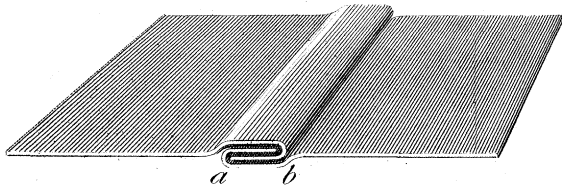

Fig: 22.

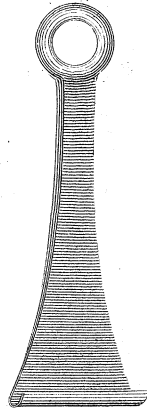

Fig: 23.

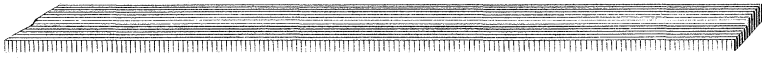

Fig: 24.



Fig: 25.

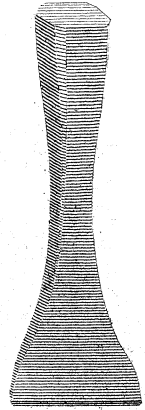

Fig: 26.

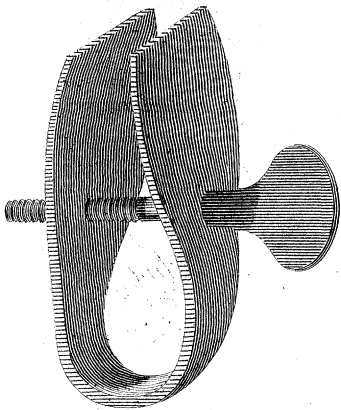

Fig: 27.

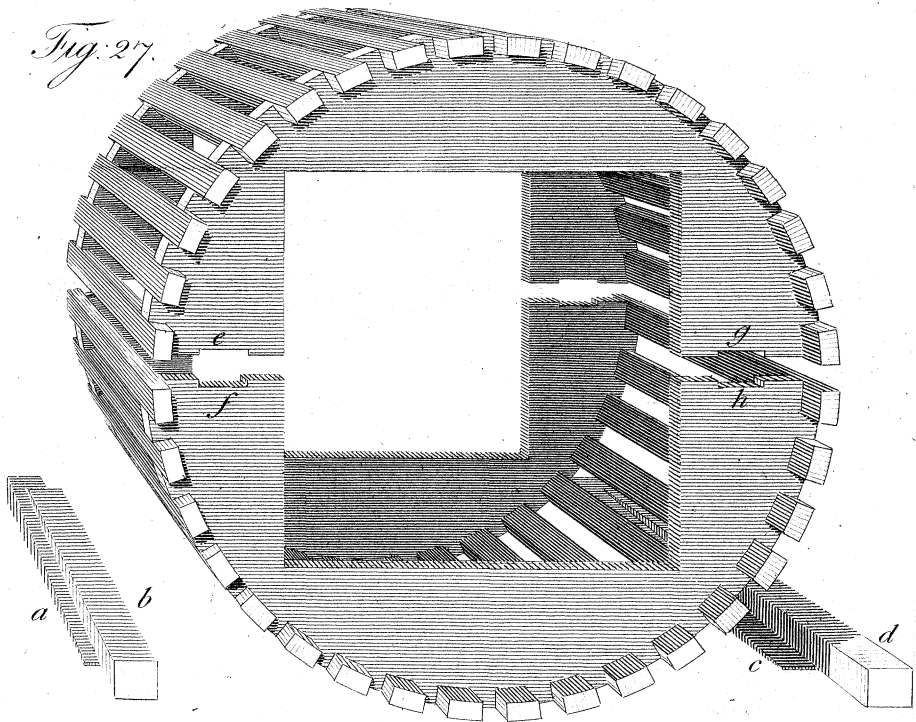

Fig. 28.

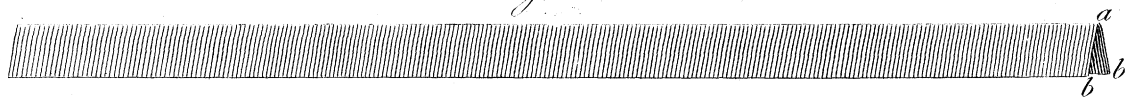

Fig. 29.

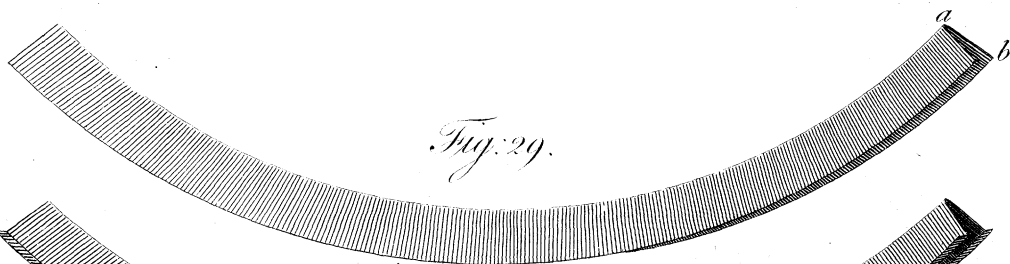

Fig. 30.

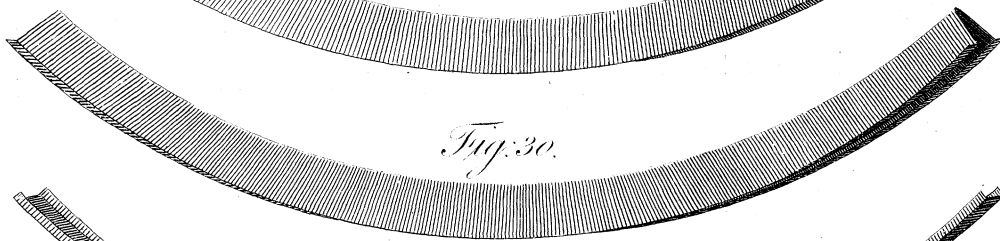

Fig. 31.



Fig. 32.

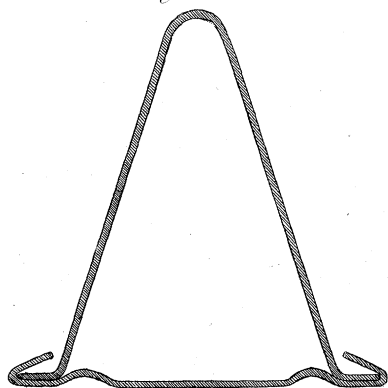

Fig. 33.

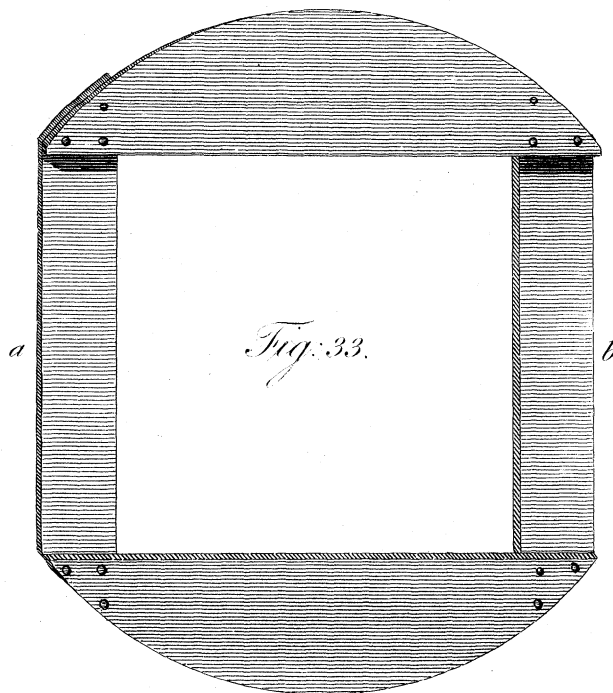

Fig. 34.

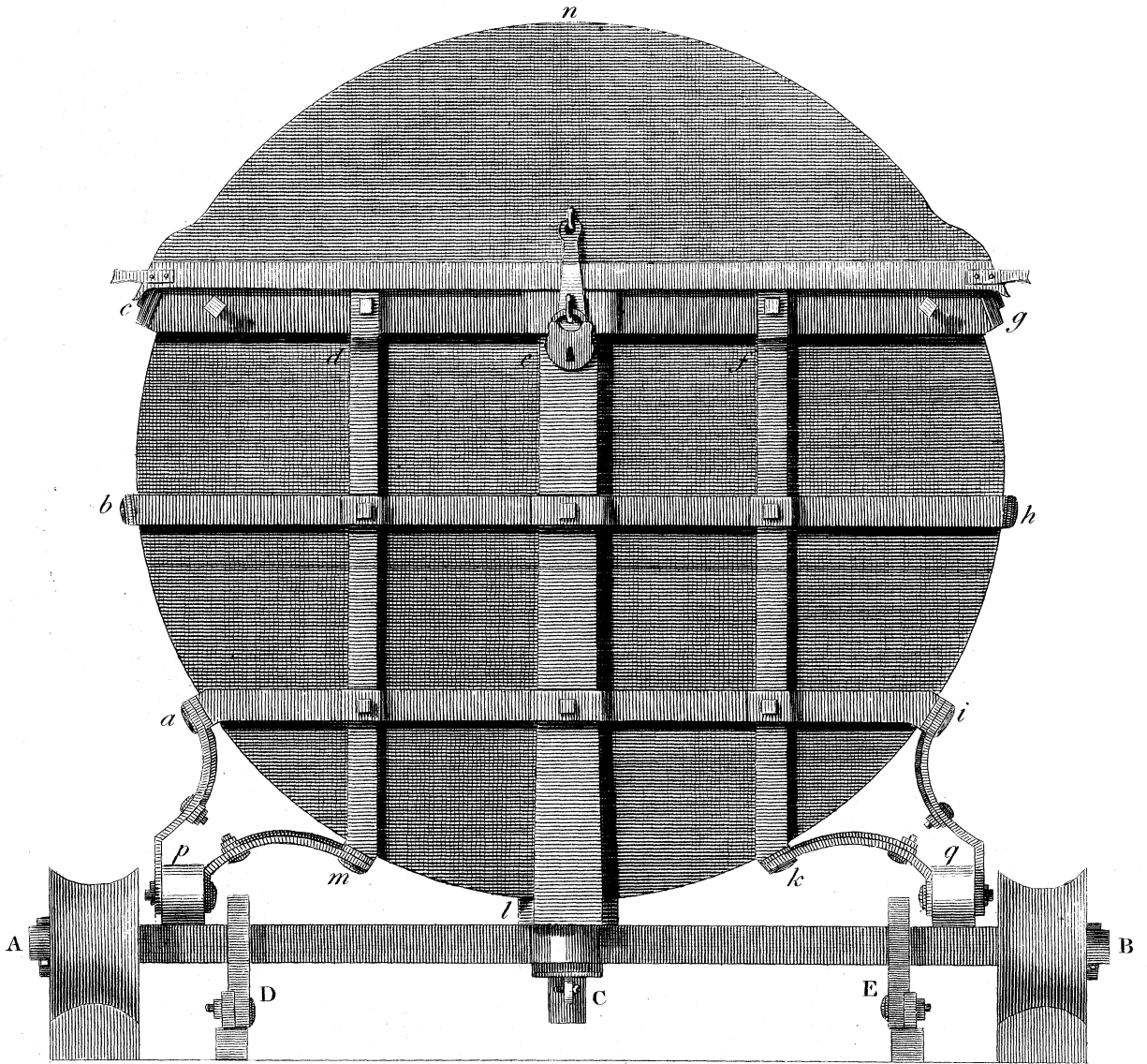

Fig. 35.

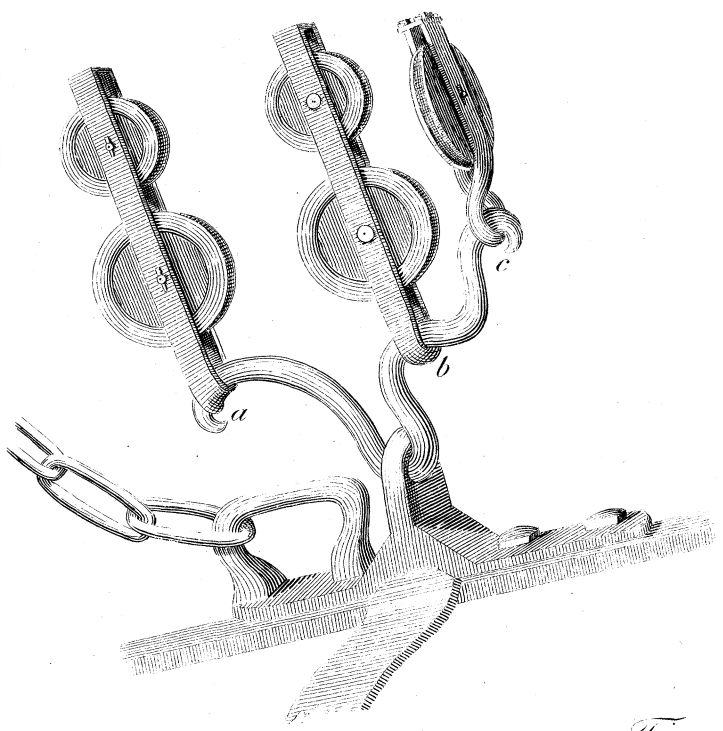

Fig. 36.

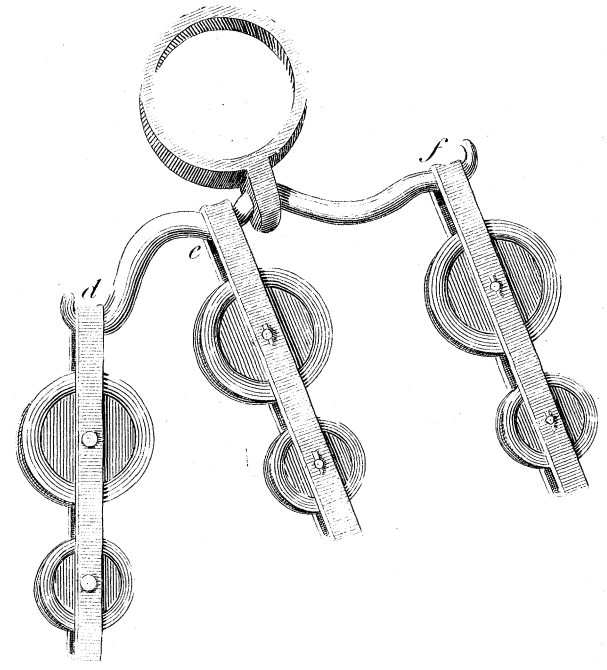

Fig. 37.

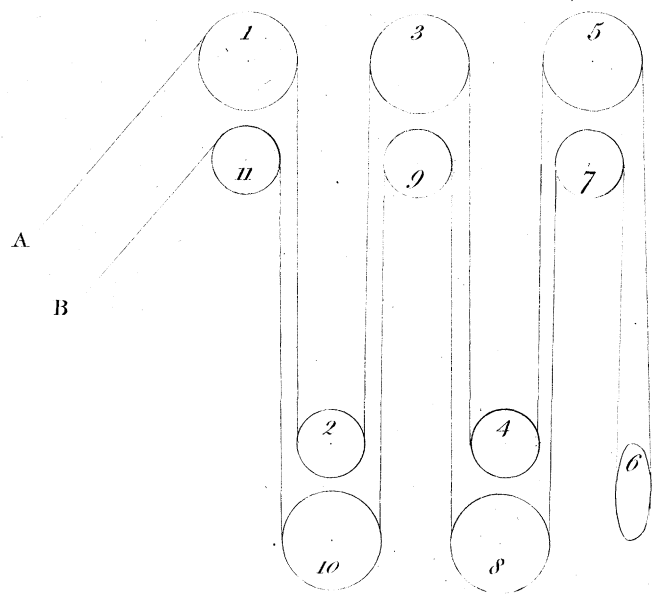

Fig. 38.

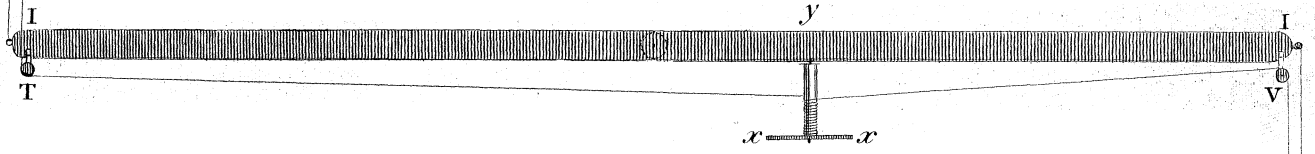
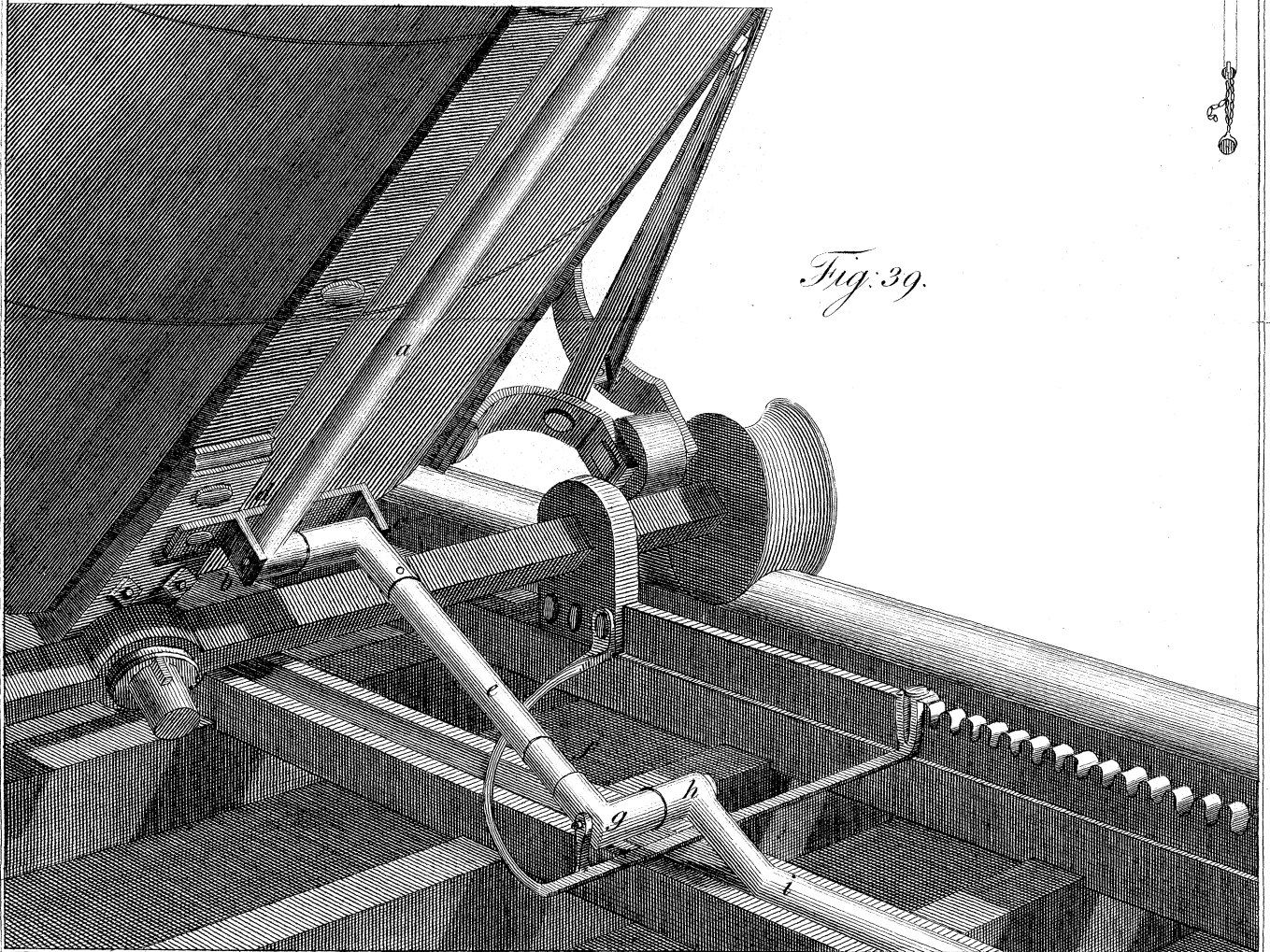

Fig. 39.



Buffon Sc.



Fig. 40.

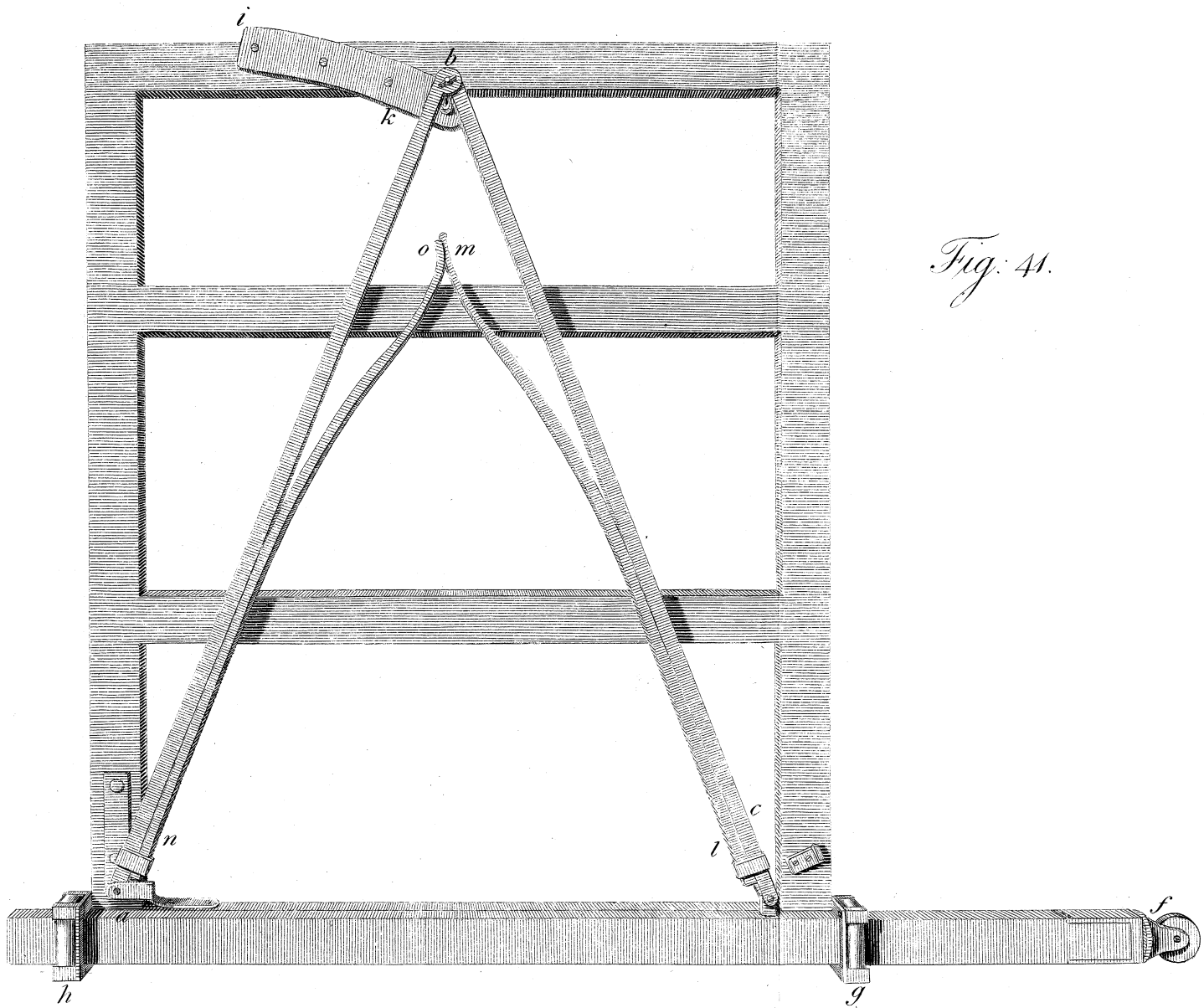

Fig. 41.

Fig. 42.

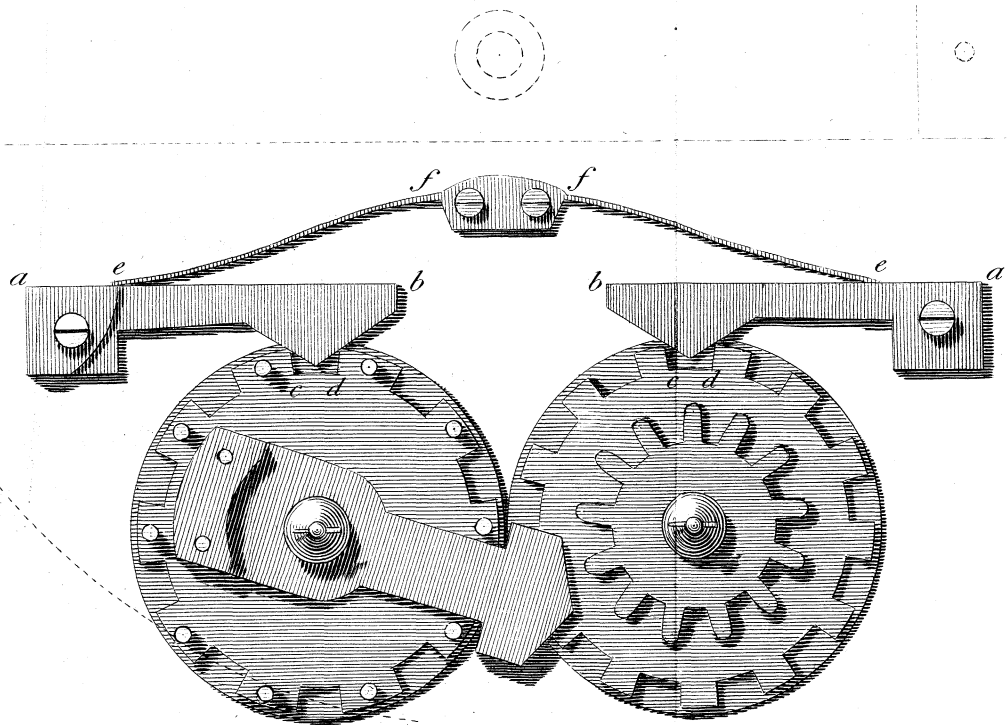
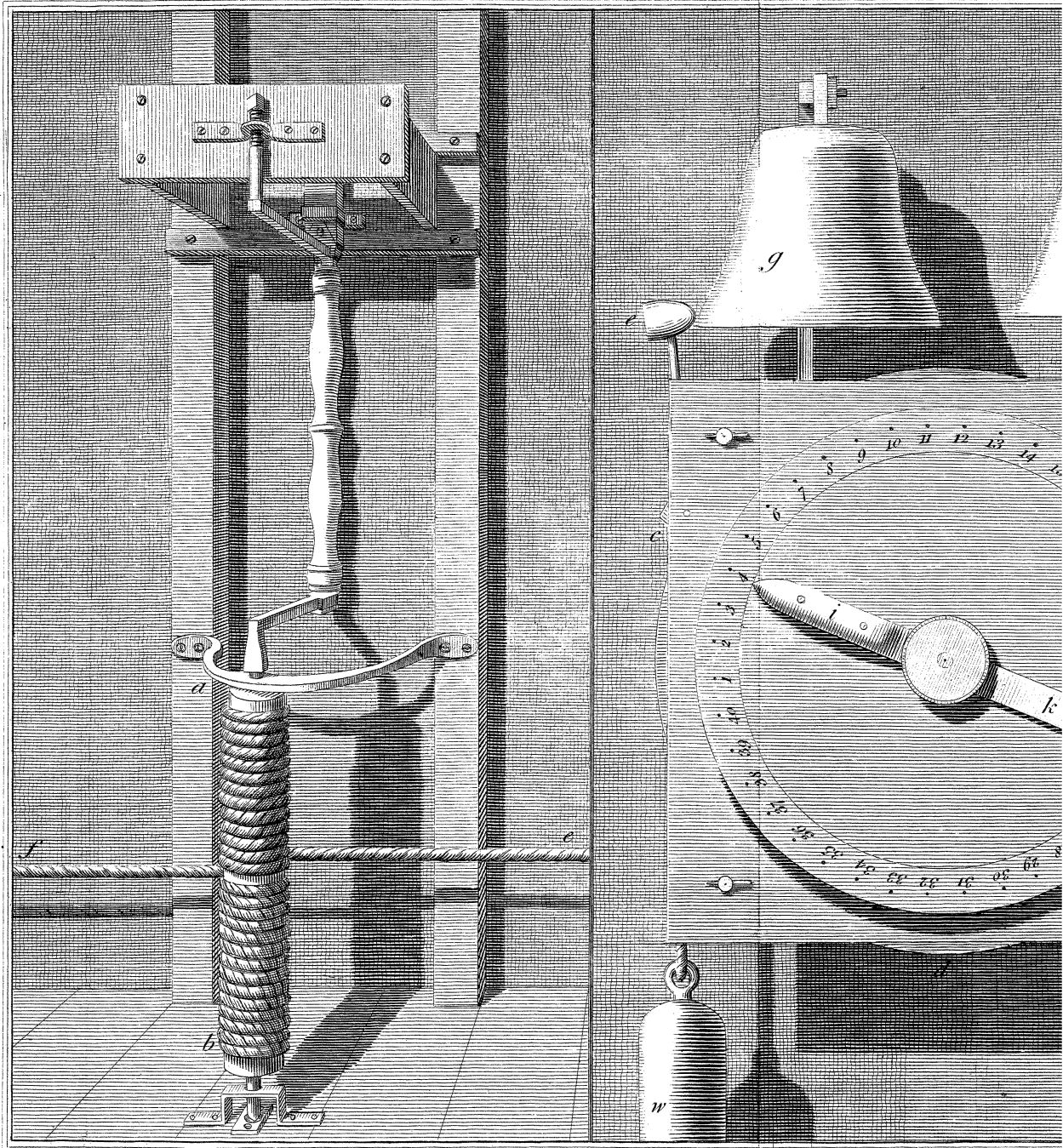
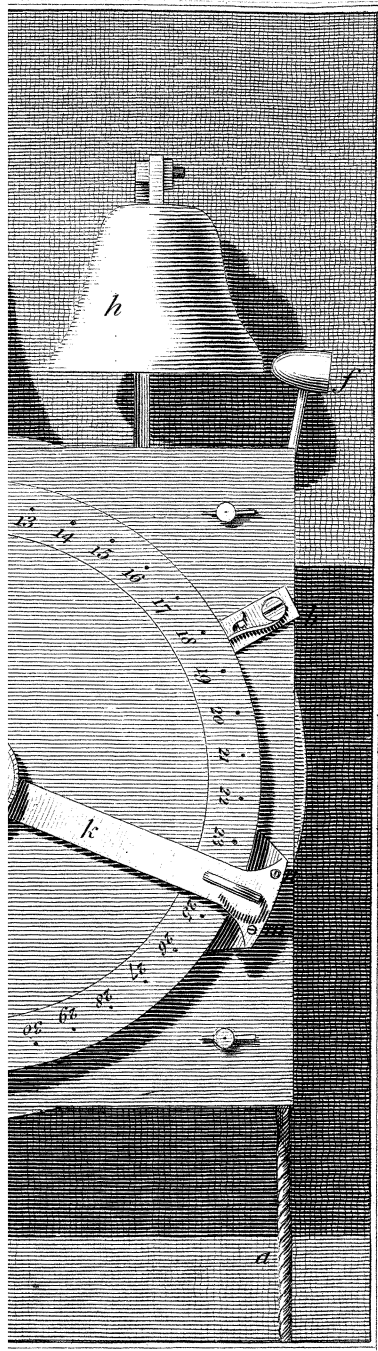

Fig.
43.





*Fig.
44.*

Boyer Sc.

Fig: 45.

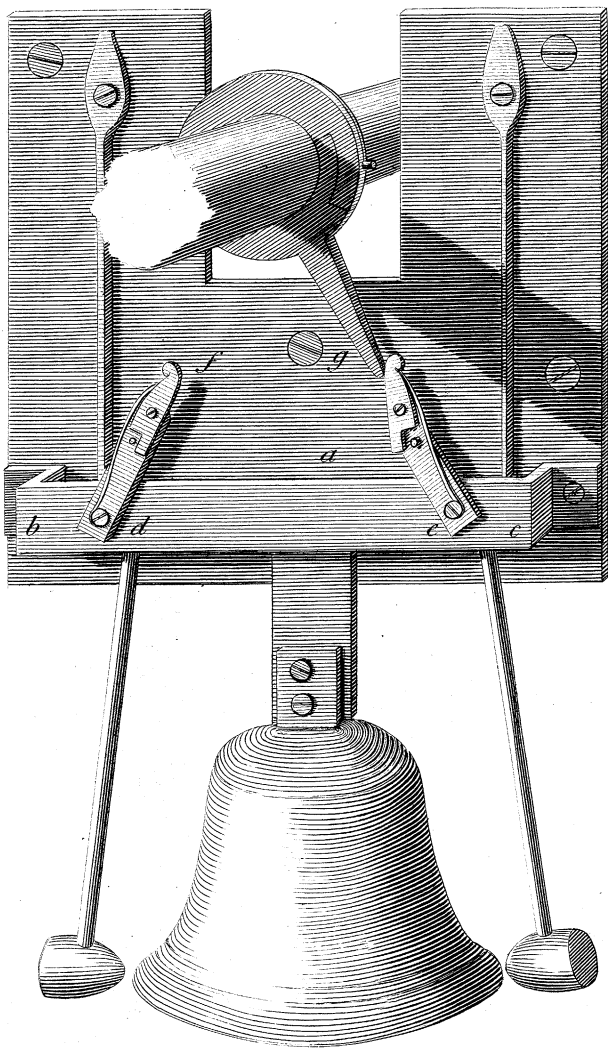
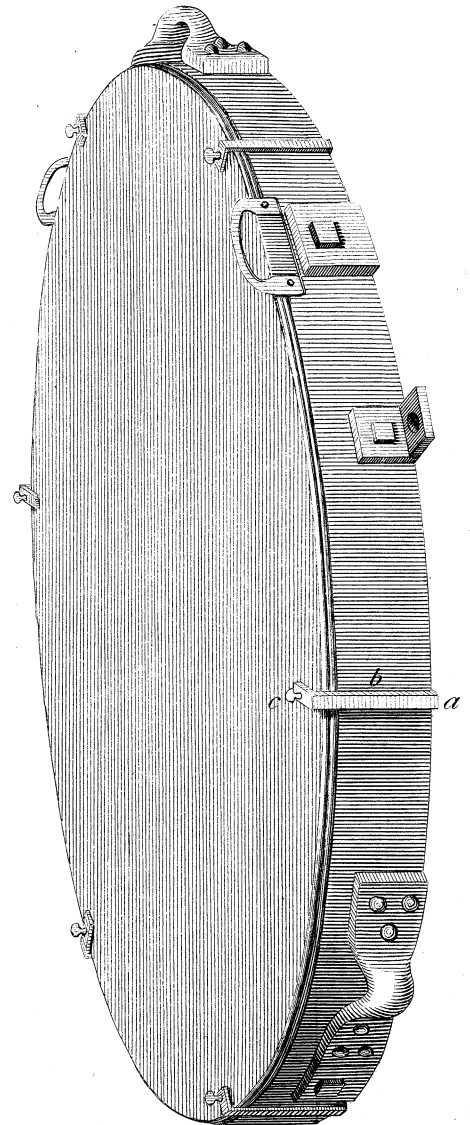

Fig: 46.



Fig: 47.



comes to take place, a light iron frame with two small wheels, or rather rollers, is pinned to the ends of them. This not only keeps them together, but also supports them sufficiently as far as they are to come out.

A slider, upon an adjustable foundation, is planted at the mouth of the telescope so as to be directed towards the centre of the mirror. It carries a brass tube, into which all the single eye-glasses, or micrometers, are made to slide. When they are nearly brought to the focus, a milled head under the end of the tube turns a bar, the motion of which adjusts them completely.

The focus of the great mirror is directed to its proper place, by putting two plates with springs upon the rim that limits the aperture of the tube, into two places which are marked. Then a cap with a small hole being put into the sliding tube, an assistant with a proper handle must screw in or out one or other of the adjusting screws at the back of the mirror, till the plates upon the aperture in front of the telescope become both visible; for they are contrived so that when the mirror is not properly adjusted, either one or both will vanish. At the same time these plates, by their situation, serve to inform us which of the screws, whether that to the right or that to the left, is in fault, by which means the adjustment becomes a very easy operation.

Slough, near Windsor,
May 18, 1795.

WM. HERSCHEL.

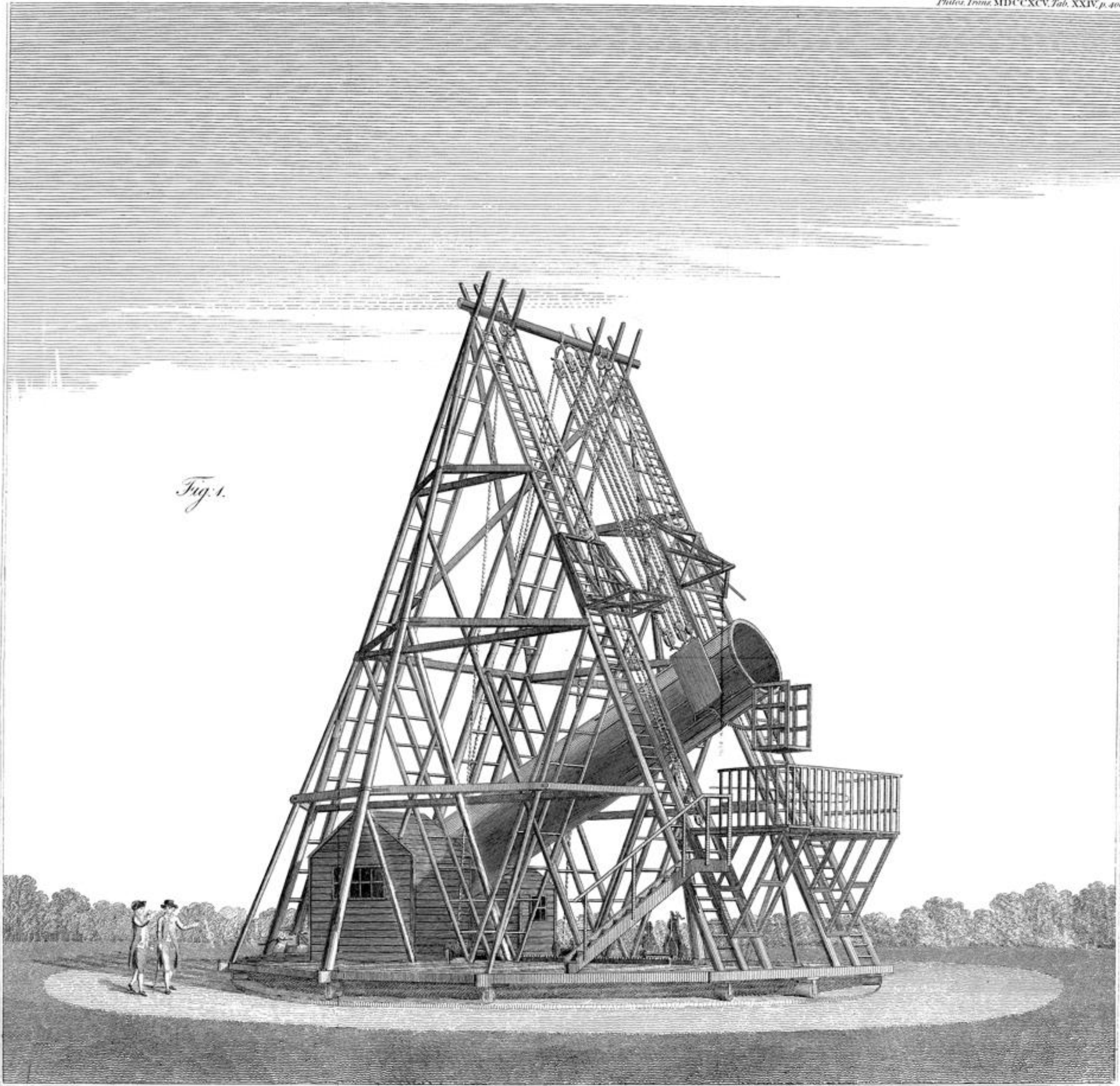
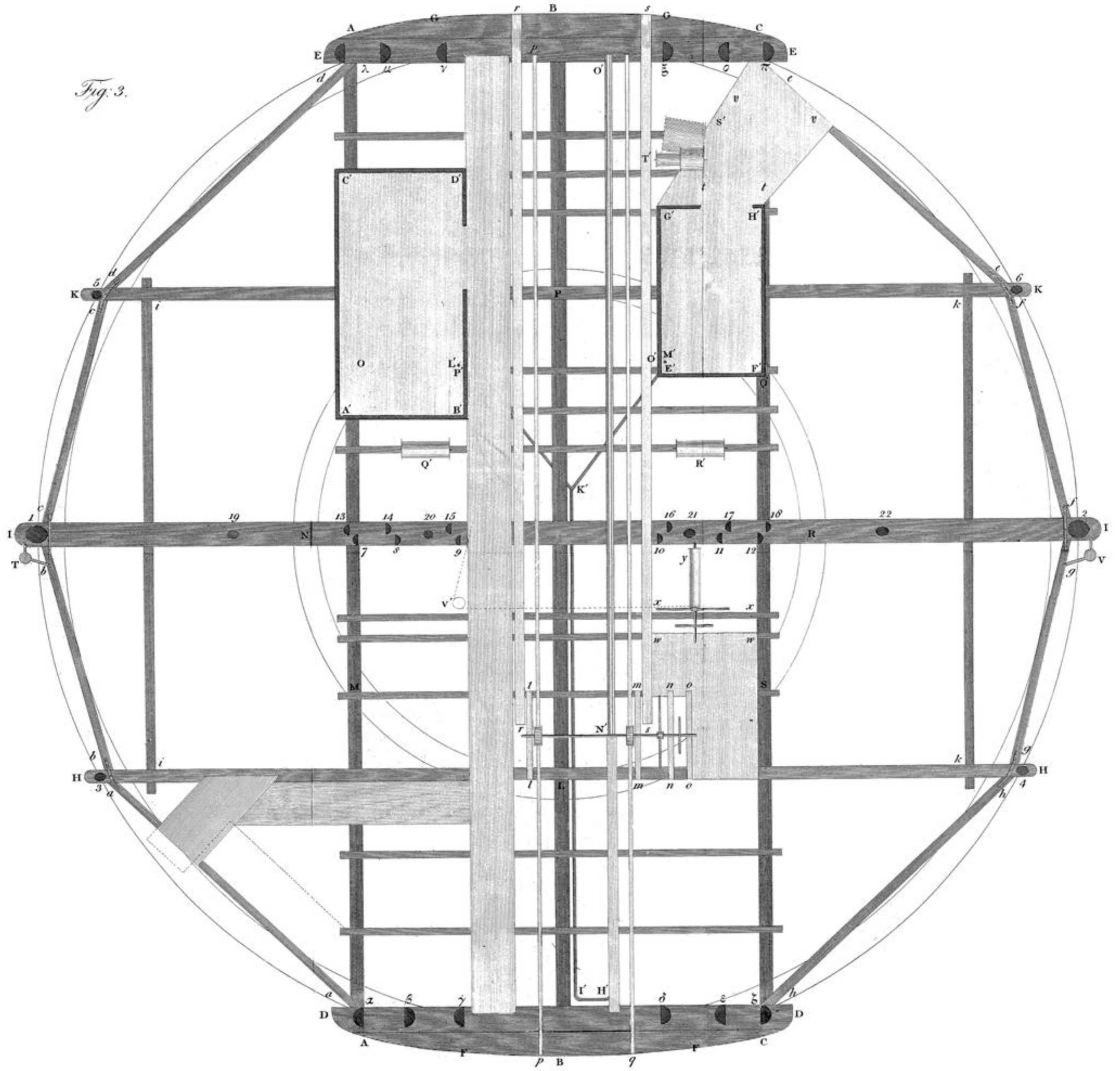

Fig. 1.

TO GEORGE THE THIRD KING OF GREAT BRITAIN &c.

This View of a Forty Feet Telescope, constructed under his Royal Patronage, is with permission, most humbly inscribed, by his Majesty's very devoted and Loyal Subject, and most grateful obedient Servant, William Herschel.

Fig. 3.



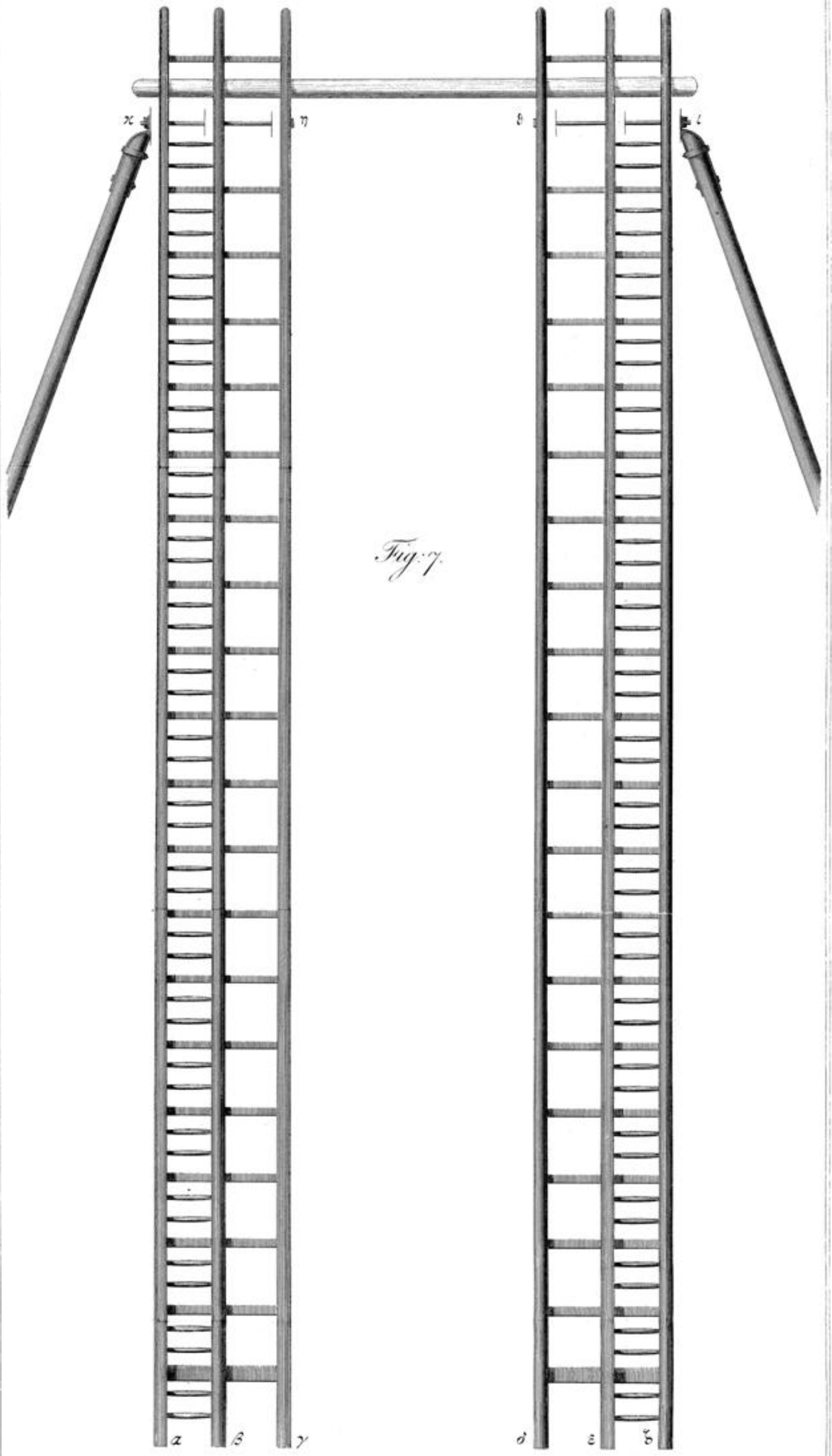

Fig. 7.



Fig. 16.



Fig. 18.

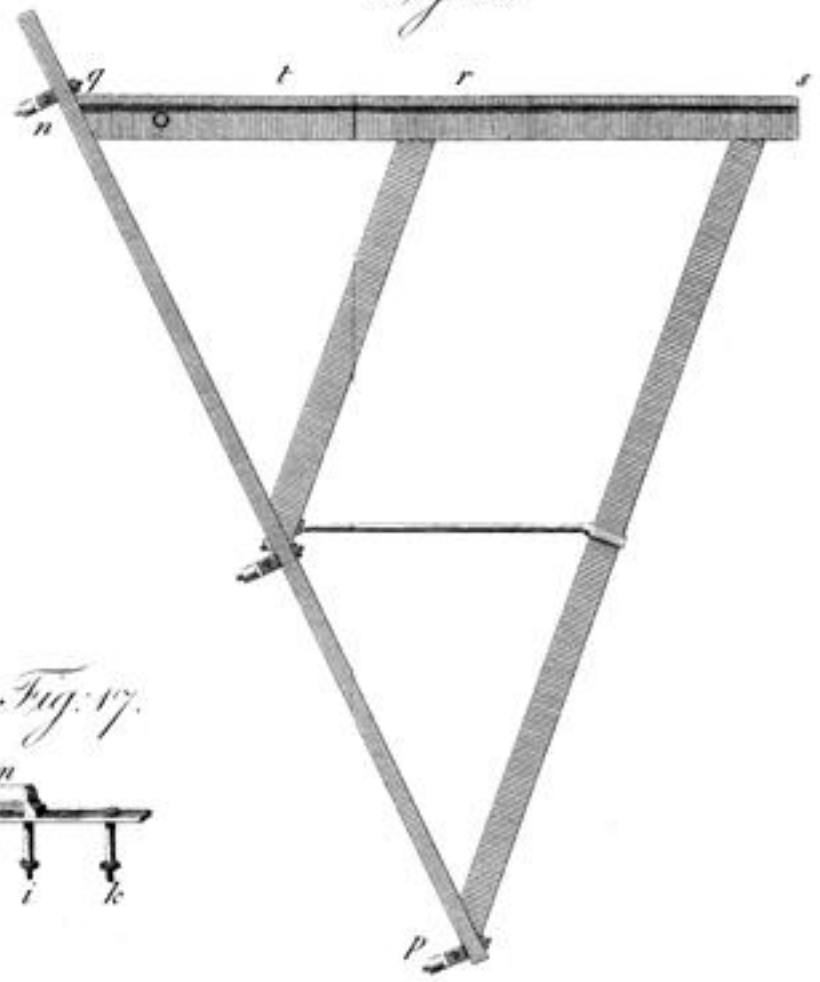
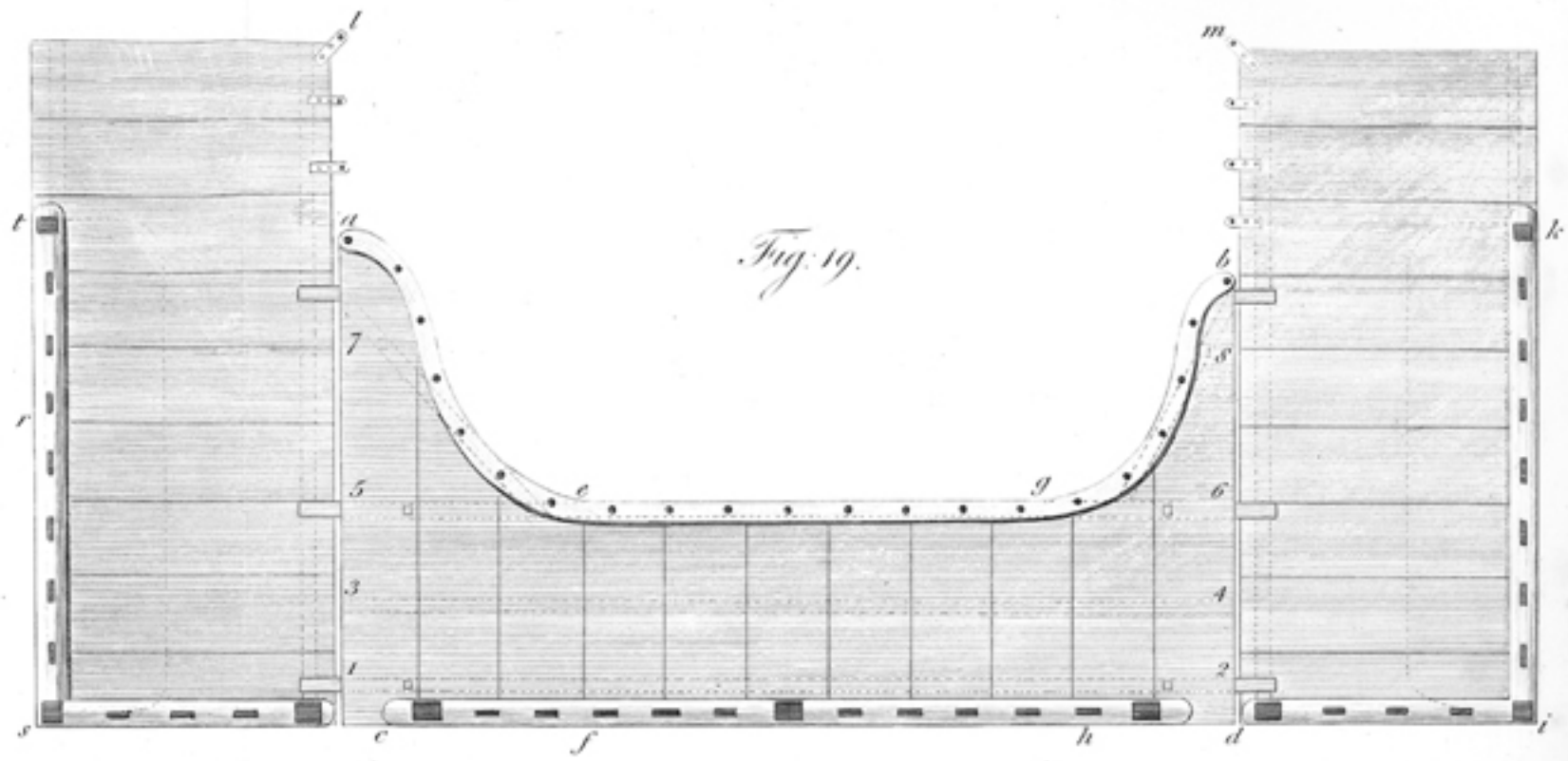

Fig. 17.





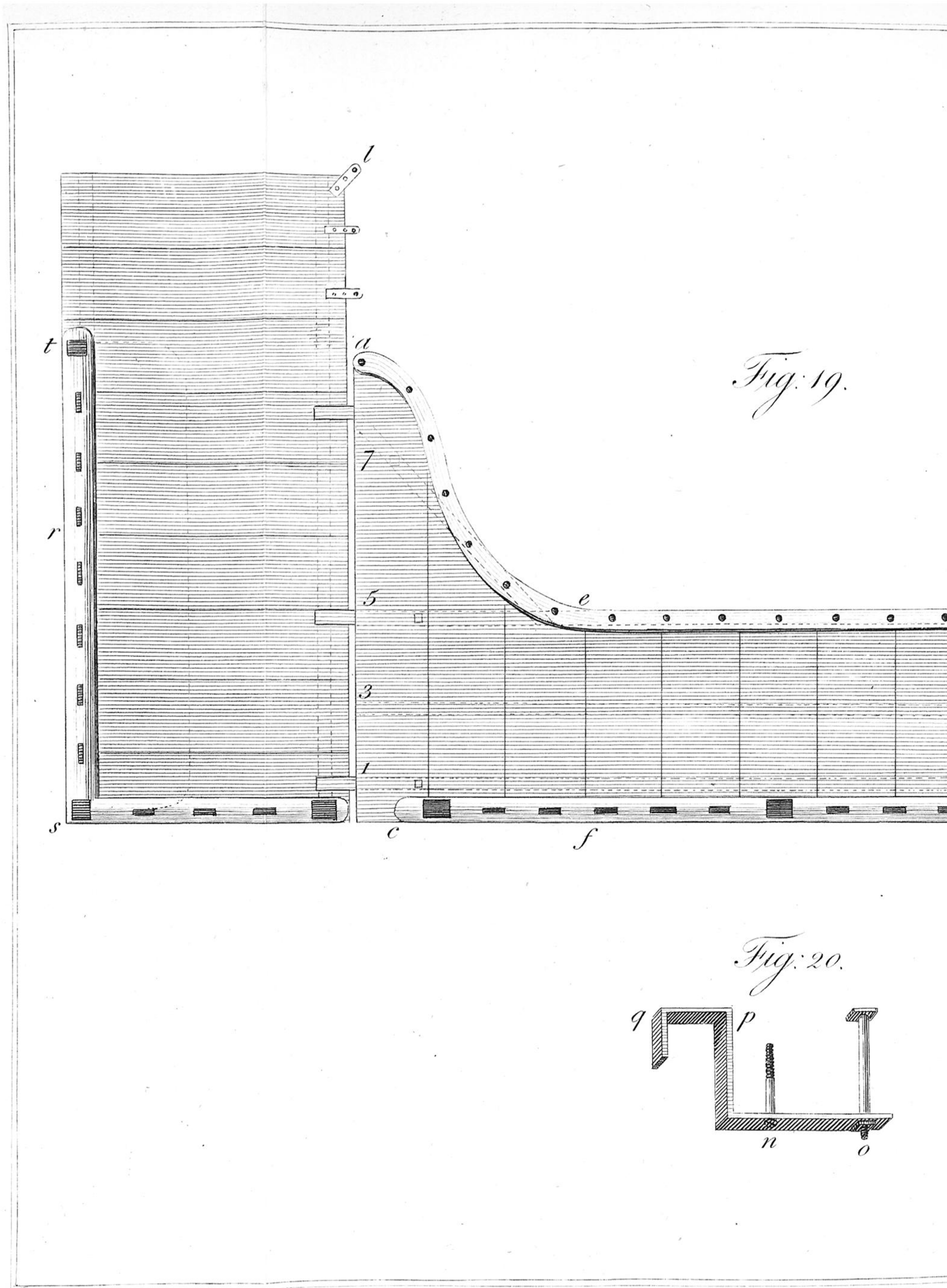

Fig: 19.

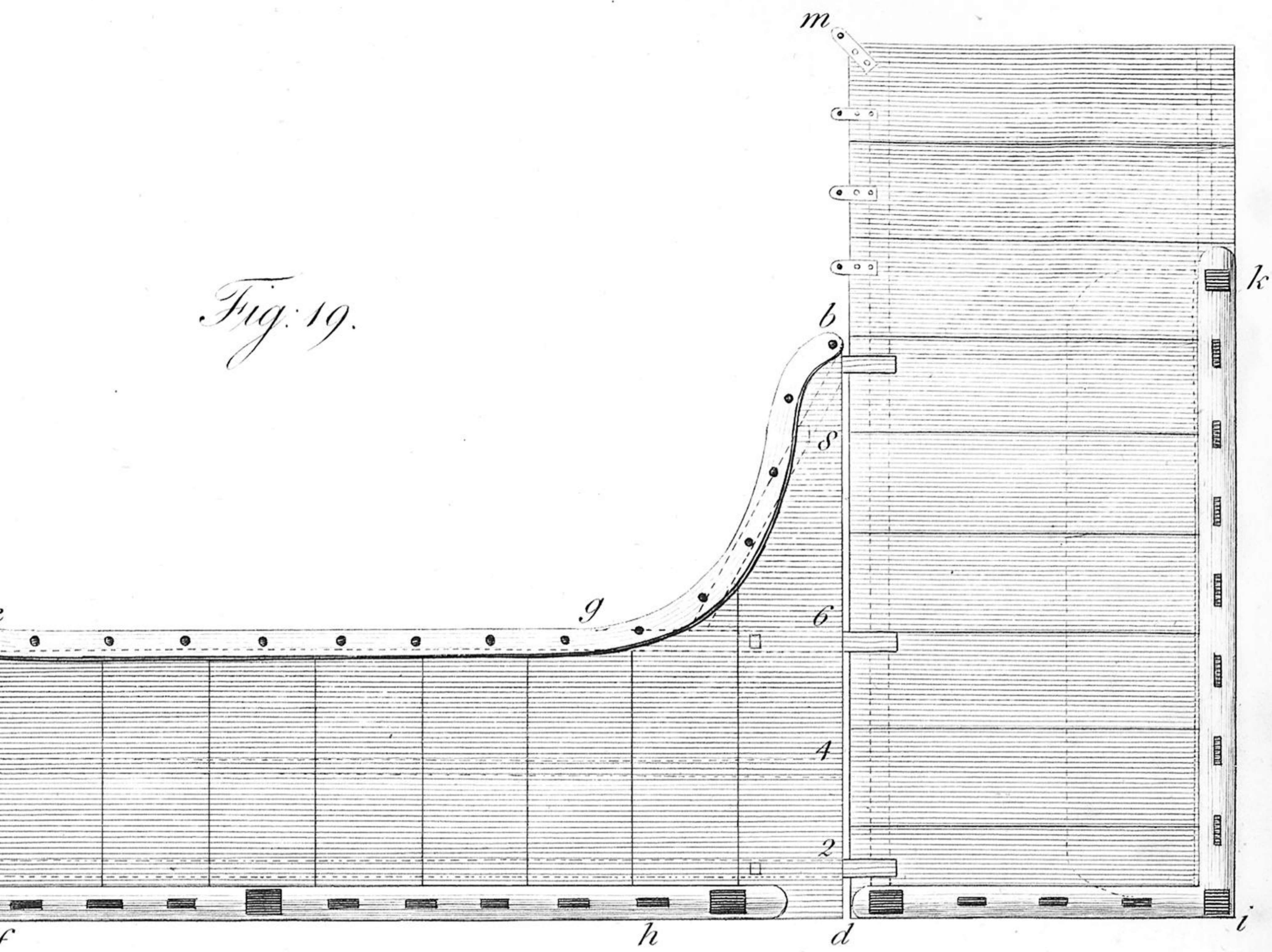

Fig: 20.

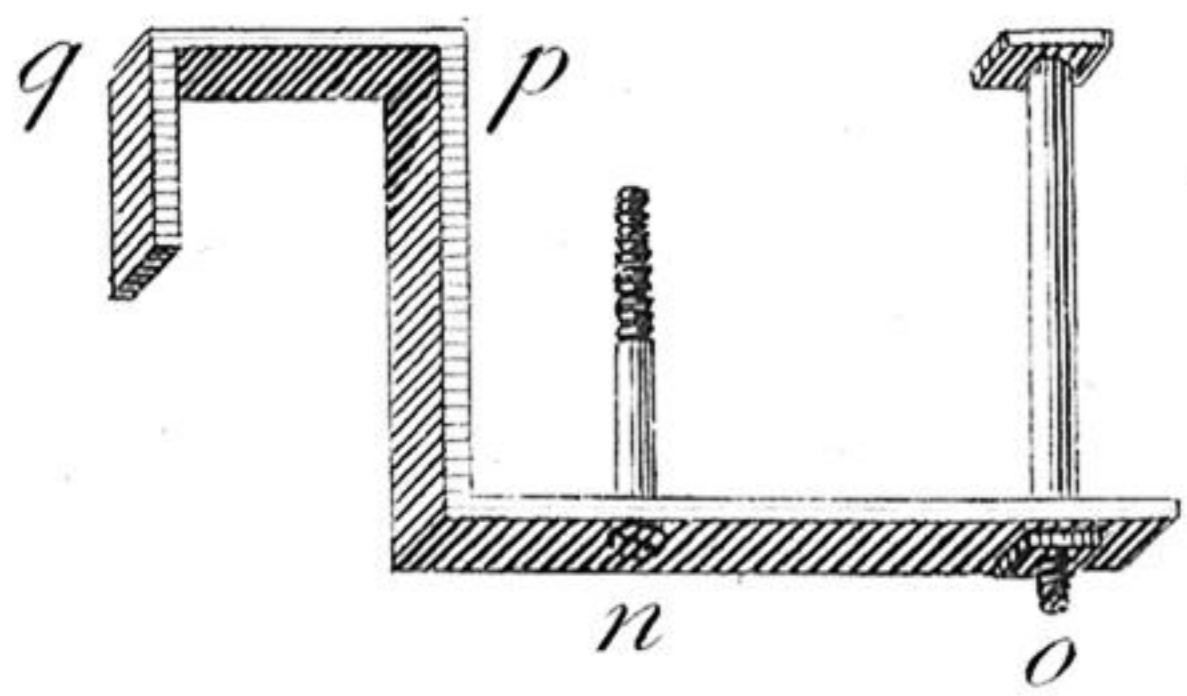

Fig.
43.

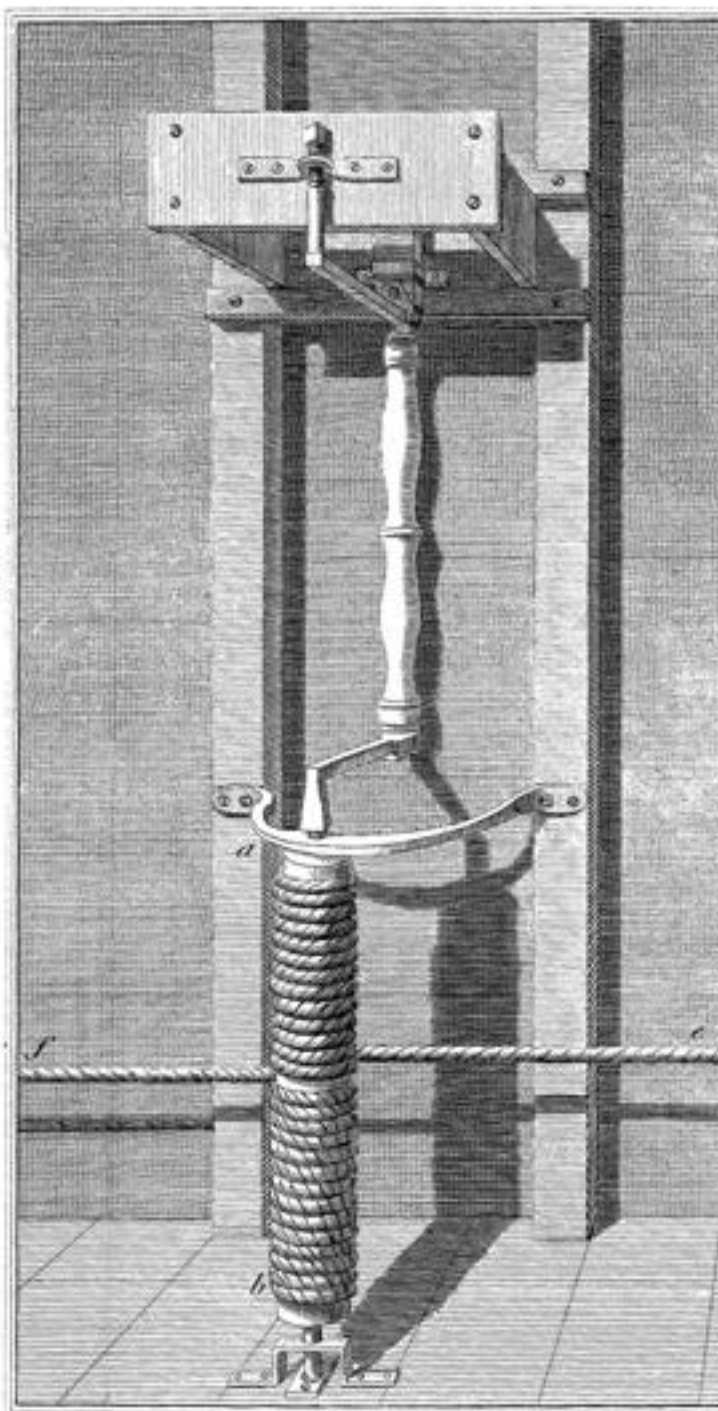
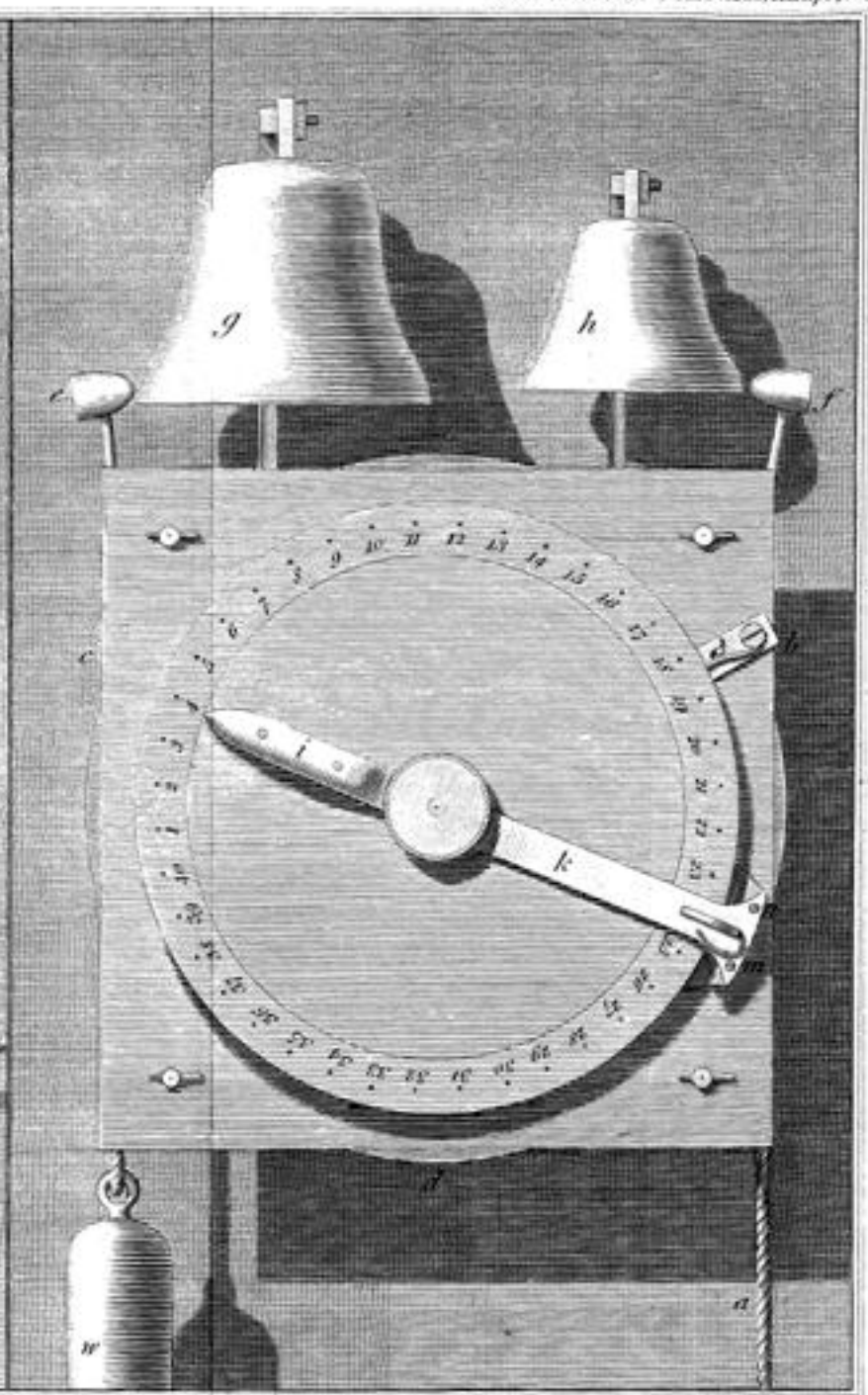

Fig.
44.



By m. s.